

DISCLAIMER: The use of this standard is governed by the "Texas Engineering Practice Act". No warranty of any kind is made by TxDOT for any purpose whatsoever. TxDOT assumes no responsibility for the conversion of this standard to other formats or for incorrect results or damages resulting from its use.

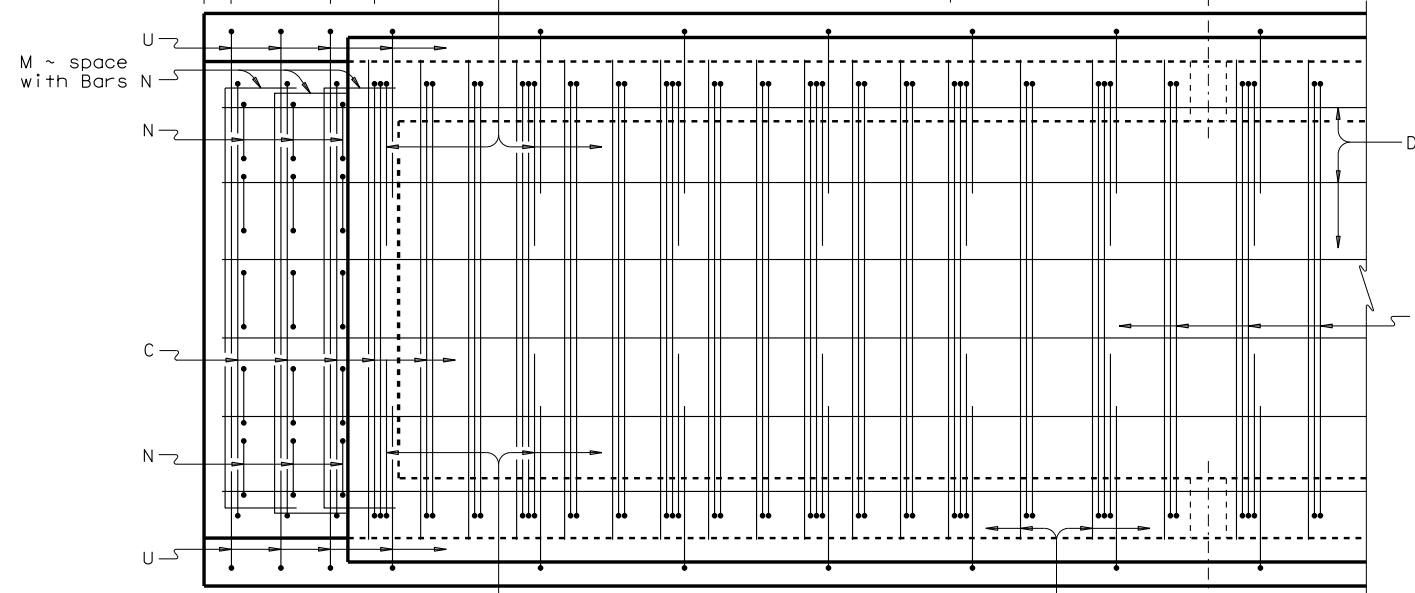

PARTIAL PLAN
(Showing Type 4B20)

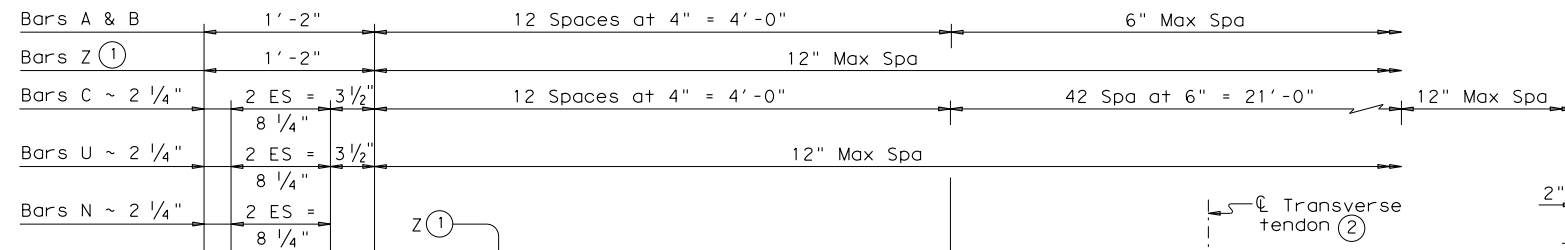
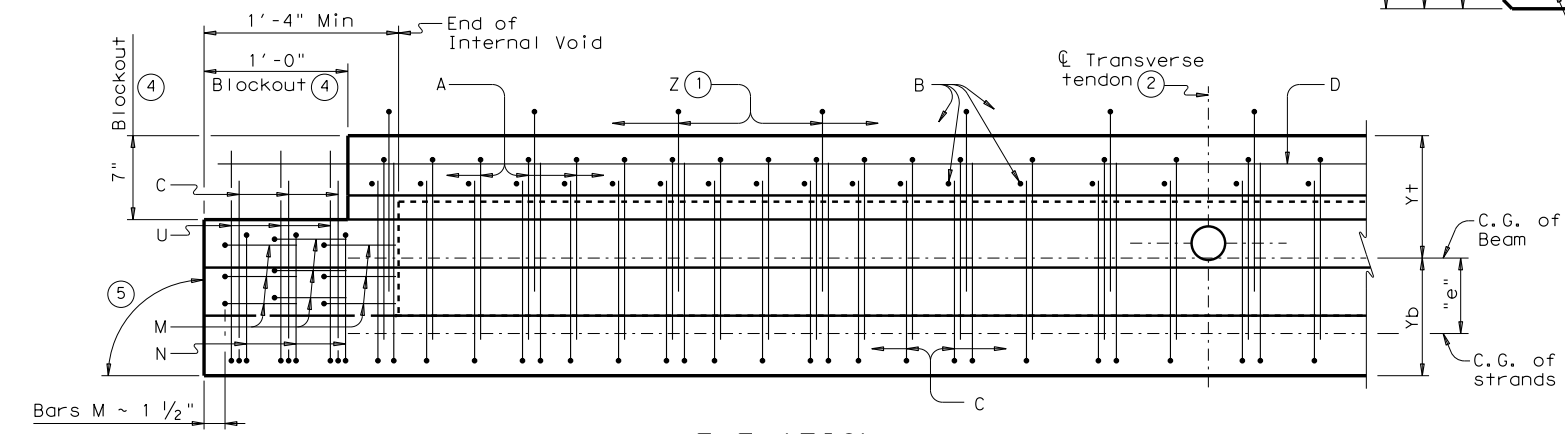

ELEVATION

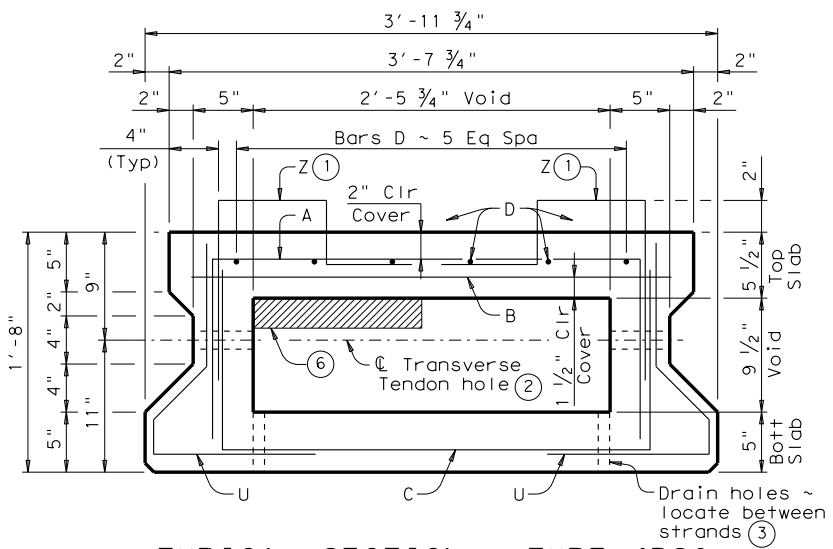

TYPICAL SECTION ~ TYPE 4B20

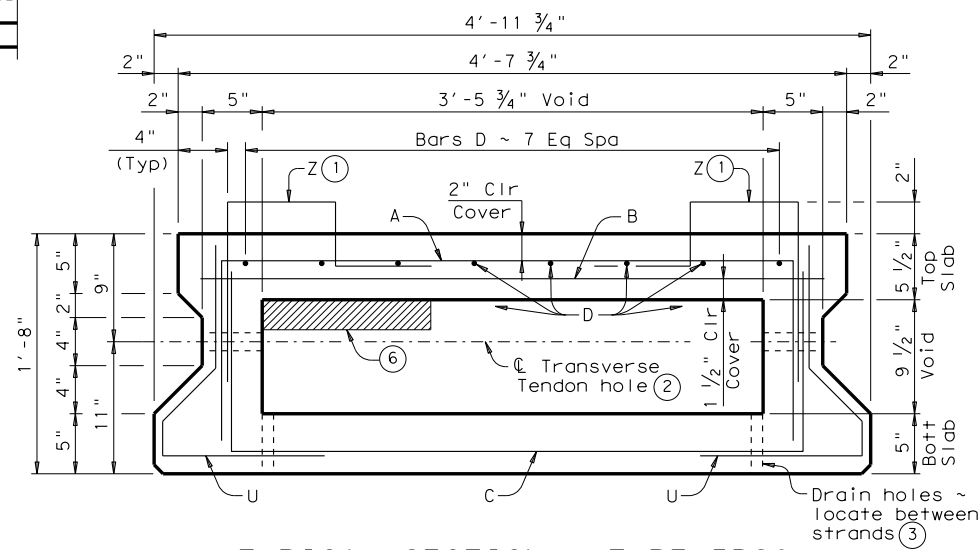

TYPICAL SECTION ~ TYPE 5B20

BEAM PROPERTIES			
		Type 4B20	Type 5B20
Area	in ²	591.8	717.8
Y top	in	10.19	10.12
Y bott	in	9.81	9.88
I	in ⁴	28,086	35,234
Weight (7)	lb/ft	616	748

- Bars Z are required for beams topped with a cast-in-place concrete slab only.
- Post-tensioning tendons are required for beams not topped with a Min 5" cast-in-place concrete slab. See span details for number and spacing of transverse tendons. Cast interior diaphragms in exterior beams and beams that serve temporarily as exterior beams in staged constructed bridges. See "Blockout, Interior Diaphragm, and Drain Details". Form 3" Dia holes in interior beams. See standard BBPT for details.
- Place drain holes (1" Dia PVC Sch 40 Pipe) as shown in all beam void corners including each side of interior diaphragms. See "Blockout, Interior Diaphragm, and Drain Details".
- Blockouts required at ends of all beams. Extend beam reinforcement into blockouts.
- 90° at conventional interior Bents. Ends of beams shall be vertical at Abutment backwall and Inverted Tee Bent Stems.
- Showing void modification required in exterior beams not topped with a Min 5" cast-in-place concrete slab. See standard BBRAO for void modification dimensions.
- Based on 150 pcf weight density of concrete. Weight of end blocks and interior diaphragms is not included.

GENERAL NOTES:
 Designed according to AASHTO LRFD Specifications. Use Class H concrete. Use Class H (HPC) if required elsewhere in plans. All reinforcing steel must be Grade 60.
 Two-stage monolithic casting is required. The concrete in the first stage cast (bottom beam flange) must remain plastic until the second stage cast (webs and top beam flange) is placed. Vibrate as required to ensure consolidation between the two casts.
 1/4" clear cover to reinforcement is required unless noted otherwise.
 See standard BBRAS or BBRAO for railing anchorage at bridge edges to be cast in beams.
 An equal area of welded wire reinforcement (WWR) meeting the requirements of ASTM A1064 may be substituted for Bars A, B, C, and D.
 These details are applicable for skews up to 30 degrees only.
 Chamfer bottom beam corners 3/4" or round to a 3/4" radius.

HL93 LOADING SHEET 1 OF 3



PRESTRESSED CONCRETE BOX BEAM DETAILS (TYPE B20)

BB-B20

FILE: bbstas01.dgn	DN: TxDOT	CK: TxDOT	DW: TxDOT	CK: TxDOT
©TxDOT December, 2006	CONT	SECT	JOB	HIGHWAY
REVISIONS				
01-12: Bars Z.	DIST	COUNTY	SHEET NO.	

DATE: FILE:

DISCLAIMER: The use of this standard is governed by the "Texas Engineering Practice Act". No warranty of any kind is made by TxDOT for any purpose whatsoever. TxDOT assumes no responsibility for the conversion of this standard to other formats or for incorrect results or damages resulting from its use.

DATE: FILE:

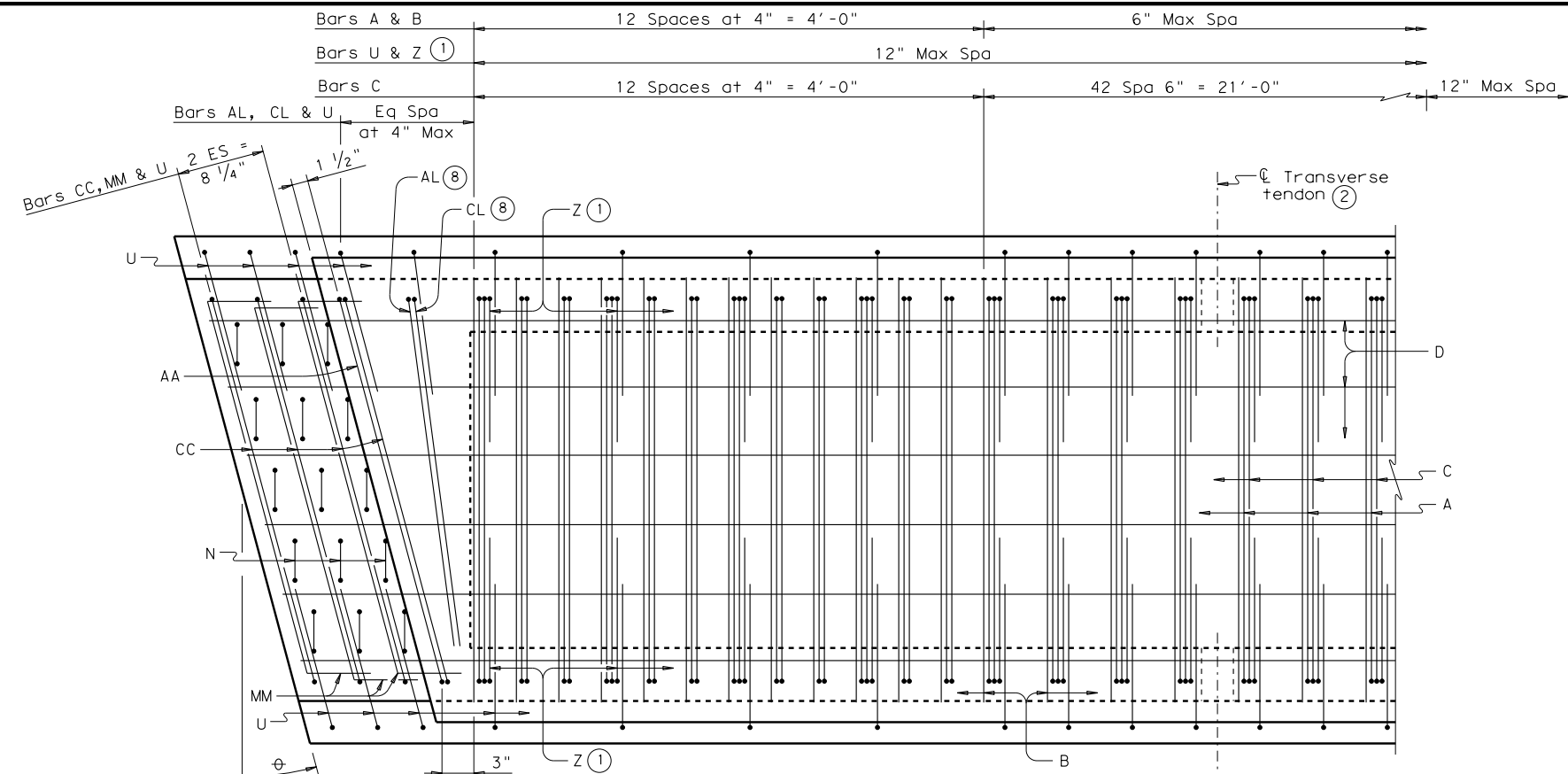

PARTIAL PLAN ~ 15° SKEW

(Showing Type 4B20)
(use for skew angles of 15° or less)

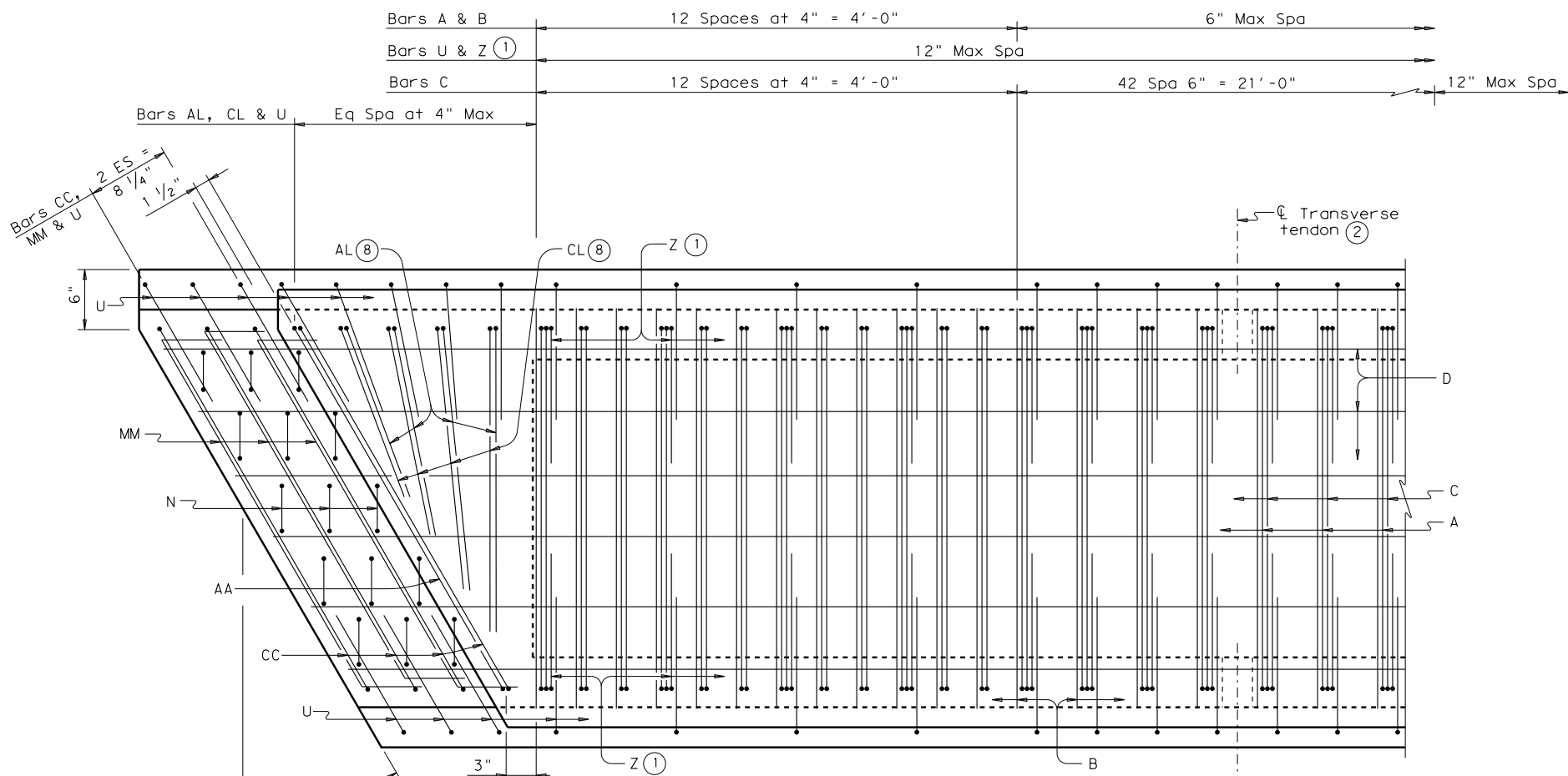

PARTIAL PLAN ~ 30° SKEW

(Showing Type 4B20)
(use for skew angles greater than 15° and less than or equal to 30°)

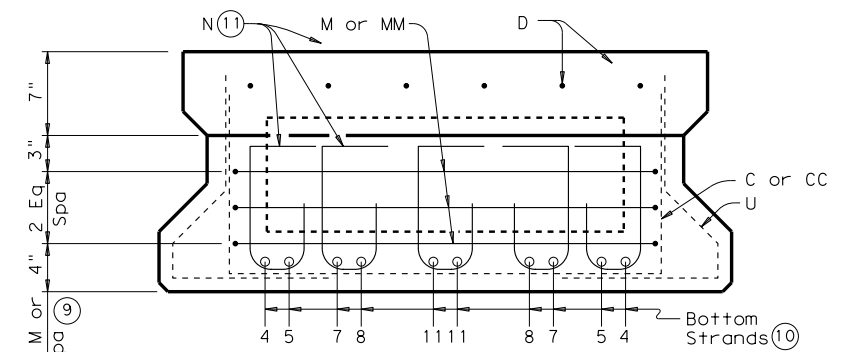

SECTION THRU BLOCKOUT ~ TYPE 4B20

(Showing End Mat Reinforcing)

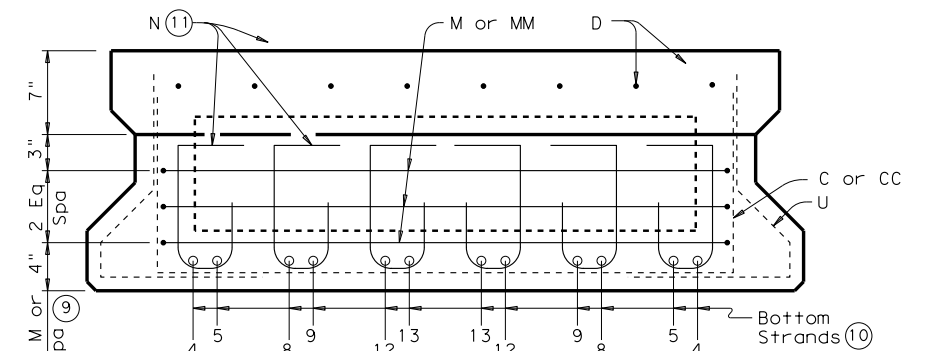

SECTION THRU BLOCKOUT ~ TYPE 5B20

(Showing End Mat Reinforcing)

- ① Bars Z are required for beams topped with a cast-in-place concrete slab only.
- ② Post-tensioning tendons are required for beams not topped with a Min 5" cast-in-place concrete slab. See span details for number and spacing of transverse tendons. Cast interior diaphragms in exterior beams and beams that serve temporarily as exterior beams in staged constructed bridges. See "Blockout, Interior Diaphragm, and Drain Details". Form 3" Dia hole in interior beams. See standard BBPT for details.
- ③ Cut as required to maintain one inch clear between bars.
- ④ Bars M may be adjusted vertically as required to avoid pretensioning strands in web.
- ⑤ See standard BBND or appropriate Prestressed Concrete Box Beam Standard Designs sheet for locations of pretensioning strands.
- ⑥ For Type 4B20 Box Beams: Bars N may be reduced to 4 bars per row when beam design contains fewer than 22 strands. In this case, place Bars N at the 5-6 and 8-9 strand locations.
- ⑦ For Type 5B20 Box Beams: Bars N may be reduced to 5 bars per row when beam design contains fewer than 28 strands. In this case, place Bars N at the 4-5, 9-10 and 14-14 strand locations.



PRESTRESSED CONCRETE BOX BEAM DETAILS (TYPE B20)

BB-B20

FILE: bbstas01.dgn	DN: TxDOT	CK: TxDOT	DW: TxDOT	CK: TxDOT
©TxDOT December, 2006	CONT	SECT	JOB	HIGHWAY
REVISIONS				
01-12: Bars Z.	DIST	COUNTY	SHEET NO.	

DISCLAIMER: The use of this standard is governed by the "Texas Engineering Practice Act". No warranty of any kind is made by TxDOT for any purpose whatsoever. TxDOT assumes no responsibility for the conversion of this standard to other formats or for incorrect results or damages resulting from its use.

DATE:
FILE:

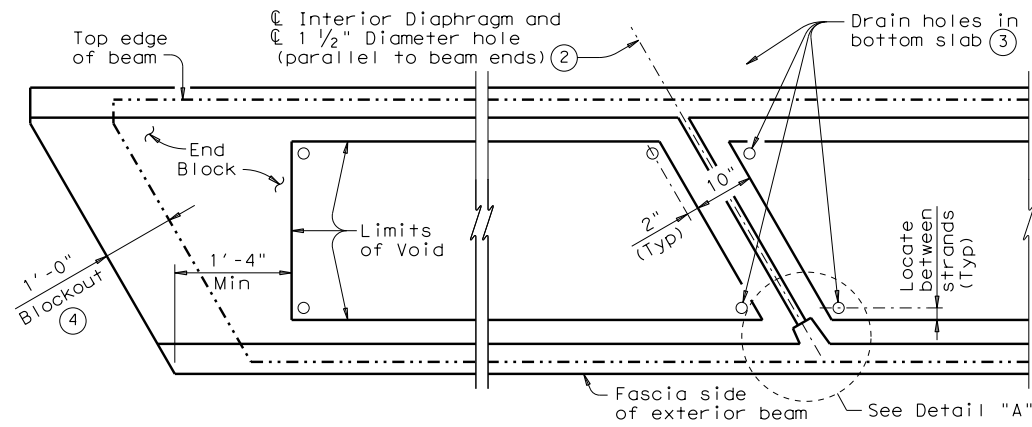

BLOCKOUT, INTERIOR DIAPHRAGM AND DRAIN DETAILS

(Showing 30° skew)

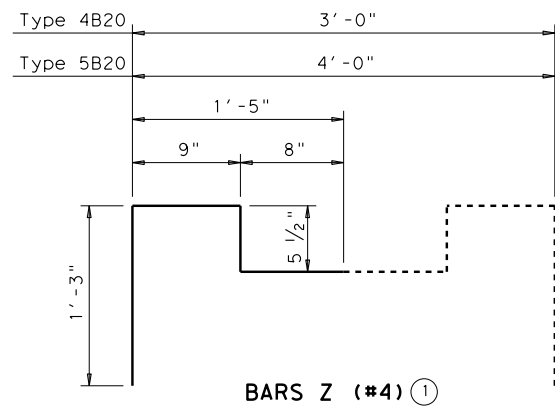
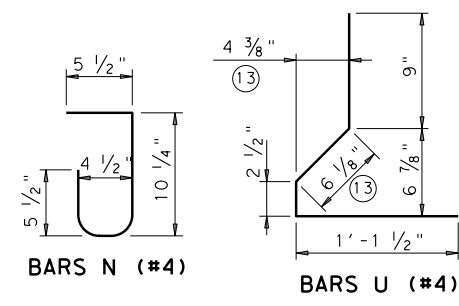
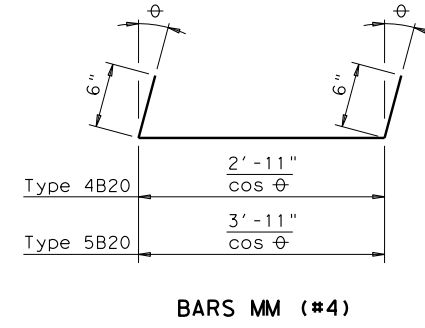
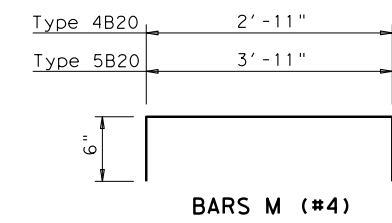
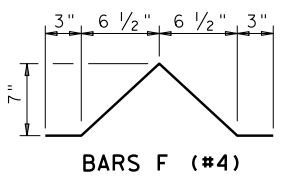
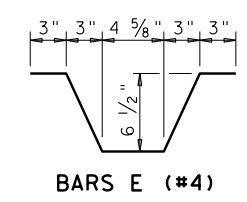
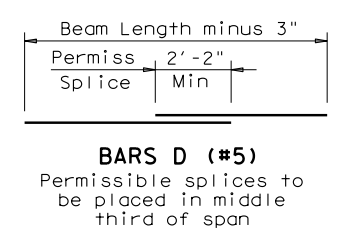
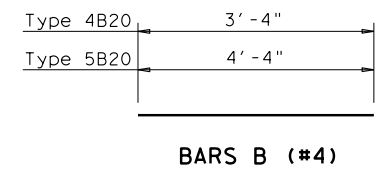
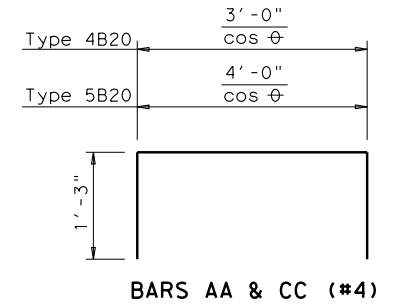
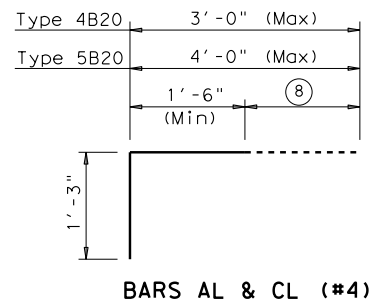
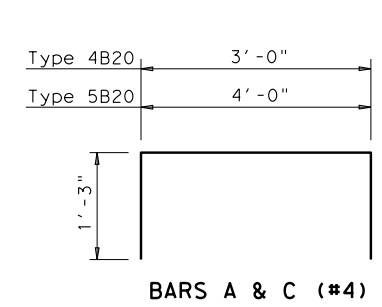
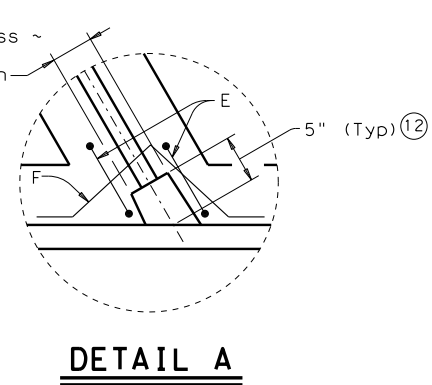
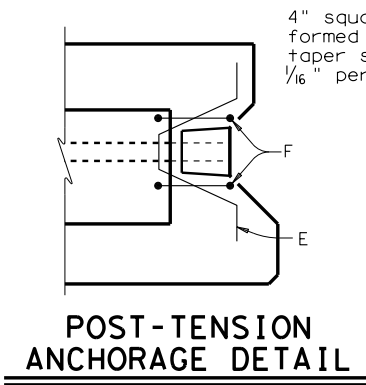

- ① Bars Z are required for beams topped with a cast-in-place concrete slab only.
- ② Post-tensioning tendons are required for beams not topped with a Min 5" cast-in-place concrete slab. See span details for number and spacing of transverse tendons. Cast interior diaphragms in exterior beams and beams that serve temporarily as exterior beams in staged constructed bridges. Form 3" Dia holes in interior beams. See "Blockout, Interior Diaphragm, and Drain Details". See standard BBPT for details.
- ③ Place drain holes (1" Dia PVC Sch 40 Pipe) as shown in all beam void corners including each side of interior diaphragms. See "Blockout, Interior Diaphragm, and Drain Details".
- ④ Blockouts required at ends of all beams. Extend beam reinforcement into blockouts.
- ⑧ Cut as required to maintain one inch clear between bars.
- ⑫ 5" (Typ) or sufficient depth to provide 1" Cover on cut-off tendon. See BBPT for details.
- ⑬ Dimension will vary slightly with skew. Adjust as necessary.

At fabricator's option, Bars Z pairs may be fabricated using one continuous bar. If this option is used, Bars B at Bar Z locations (only) may be omitted.



PRESTRESSED CONCRETE BOX BEAM DETAILS (TYPE B20)

BB-B20

FILE: bbstds01.dgn	DN: TxDOT	CK: TxDOT	DW: TxDOT	CK: TxDOT
©TxDOT December, 2006	CONT	SECT	JOB	HIGHWAY
REVISIONS				
01-12: Bars Z.	DIST	COUNTY	SHEET NO.	