

DISCLAIMER: The use of this standard is governed by the "Texas Engineering Practice Act". No warranty of any kind is made by TxDOT for any purpose whatsoever. TxDOT assumes no responsibility for the conversion of this standard to other formats or for incorrect results or damages resulting from its use.

DATE: FILE:

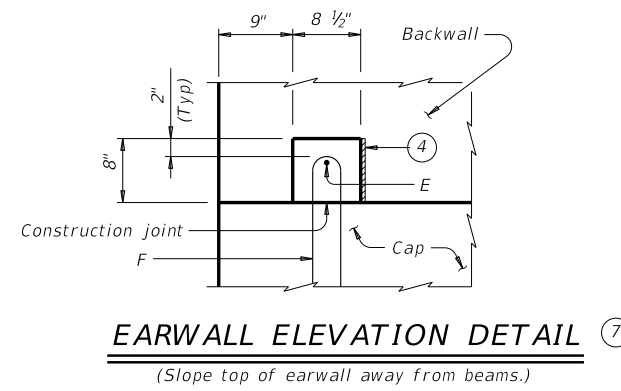
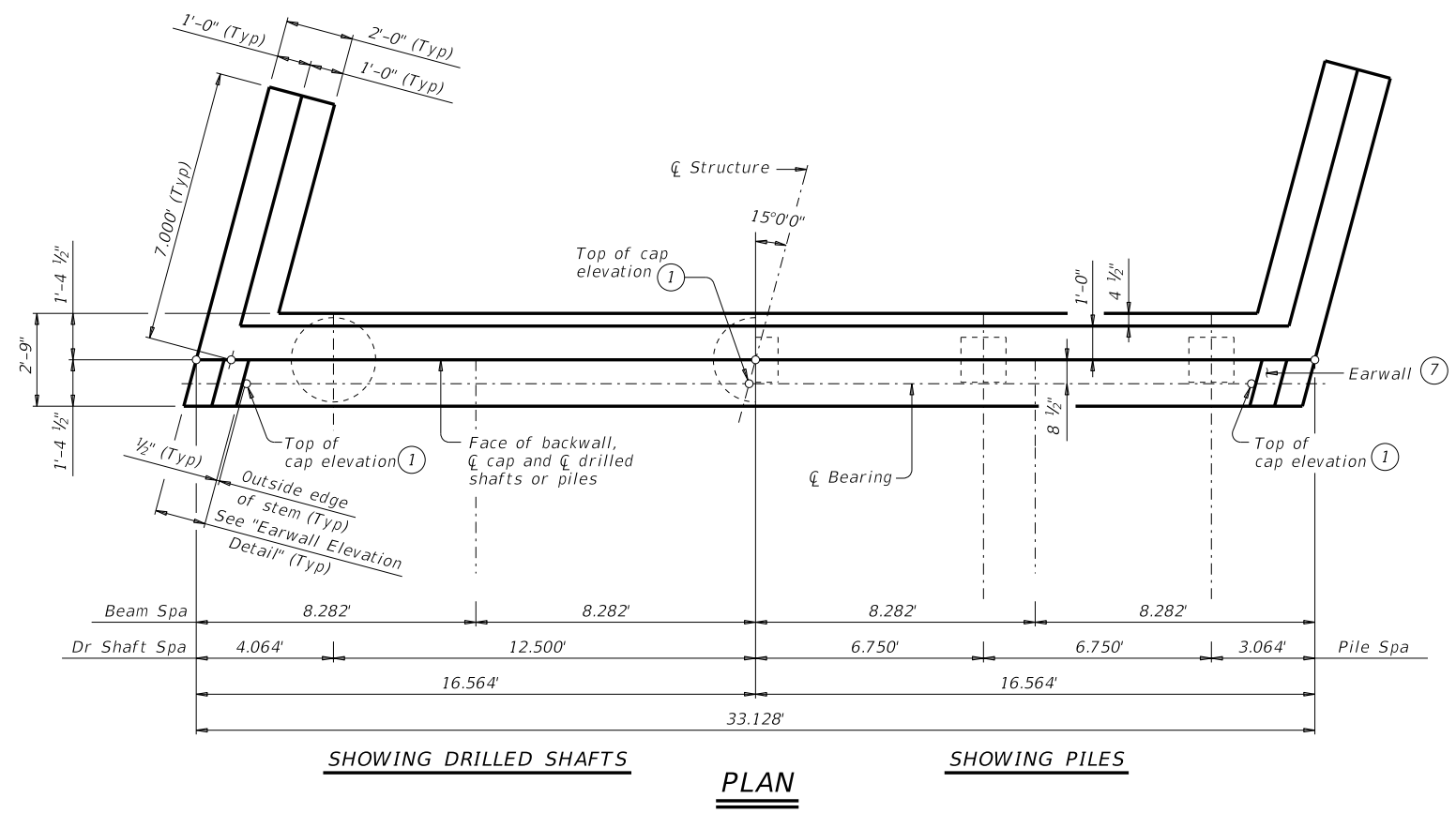

- ① Top of cap elevations are based on section depths shown on span details.
- ② 1'-8" for 8DS20 beams, 1'-11" for 8DS23 beams.
- ③ With pile foundations, replace Bar A, located at bottom centerline of cap with 4 ~ #11 x 5'-3" bars placed between piles. Deduct 59 Lbs from reinforcing steel total.
- ④ 1/2" preformed bituminous fiber material between beam stem and earwall. Bond to beam with an approved adhesive. Cast inside face of earwall with face of beam stem.
- ⑤ Surface finish top of cap with a textured, wood float. Level surface in the direction of the centerline of beams. Provide bearing surface clean and free of all loose material before placing bearing pads.
- ⑥ 2 spaces at 12" Max.
- ⑦ Do not cast earwalls until beams are erected in their final position.
- ⑧ Top of backwall elevation is equal to top of beam elevation.

**MATERIAL NOTES:**  
 Provide Class C concrete (f'c = 3,600 psi).  
 Provide Class C (HPC) concrete if shown elsewhere in the plans.  
 Provide Grade 60 reinforcing steel.

**GENERAL NOTES:**  
 Designed according to AASHTO LRFD Bridge Design Specifications.  
 Designed for normal embankment header slope of 3:1 or 2:1.  
 See Bridge Layout for header slope, beam type, and foundation type, size and length.  
 See Common Foundation Details (FD) standard sheet for all foundation details and notes.  
 See Concrete Riprap (CRR) standard sheet or Stone Riprap (SRR) standard sheet for riprap attachment details, if applicable.  
 See applicable rail details for rail anchorage in wingwalls.  
 Details are drawn showing right forward skew. See Bridge Layout for actual skew direction.  
 This abutment does not accommodate an approach slab. These abutment details may be used with standard SDSA-30-15 only.

Cover dimensions are clear dimensions, unless noted otherwise.  
 Reinforcing bar dimensions shown are out-to-out of bar.

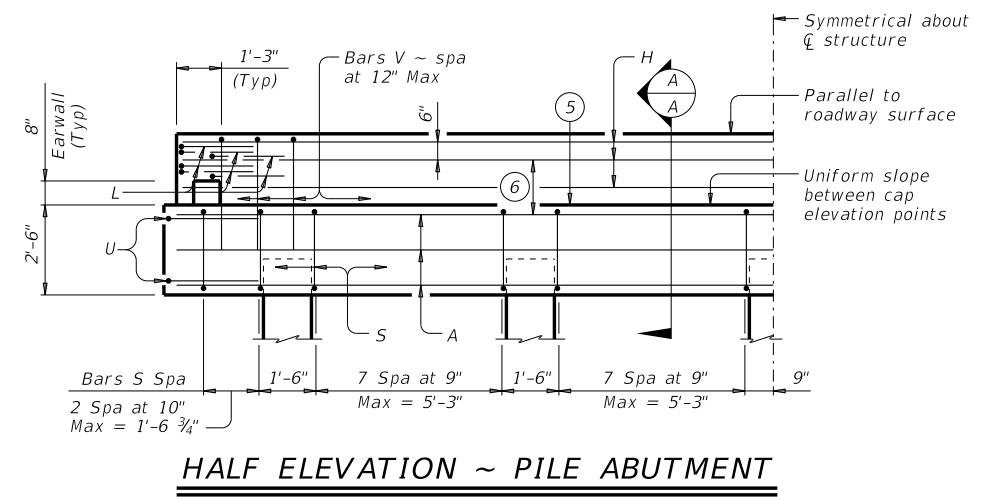
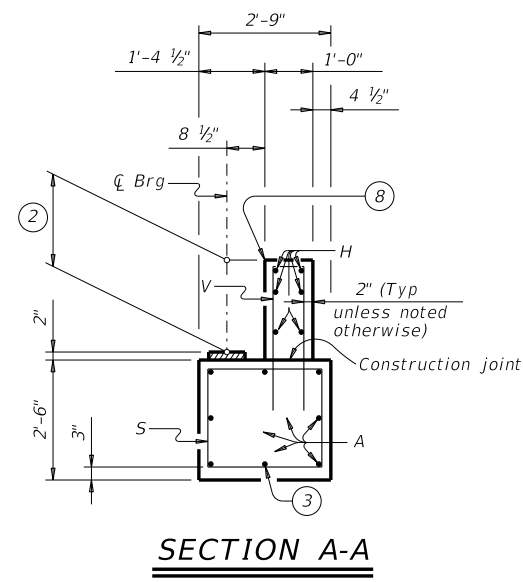
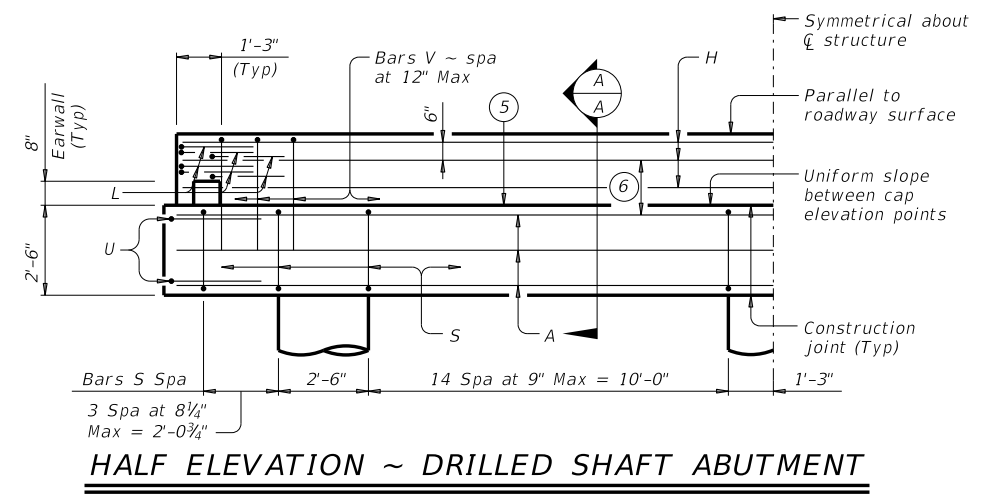

(Showing 16" piles ~ for piles larger than 16", adjust Bars S spacing as required to avoid piling.)

**Texas Department of Transportation** Bridge Division Standard

**ABUTMENTS**  
**PRESTRESSED CONCRETE**  
**DECKED SLAB BEAMS**  
**30' ROADWAY 15° SKEW**

**ADSB-30-15**

FILE: dsbste27-20.dgn	DN: JLR	CK: SDC	DW: JTR	CK: TAR
©TxDOT August 2020	CONT	SECT	JOB	HIGHWAY
REVISIONS				
DIST	COUNTY		SHEET NO.	

DISCLAIMER: The use of this standard is governed by the "Texas Engineering Practice Act". No warranty of any kind is made by TxDOT for any purpose whatsoever. TxDOT assumes no responsibility for the conversion of this standard to other formats or for incorrect results or damages resulting from its use.

DATE:  
FILE:

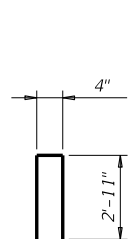
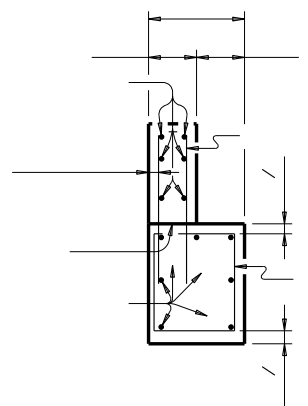
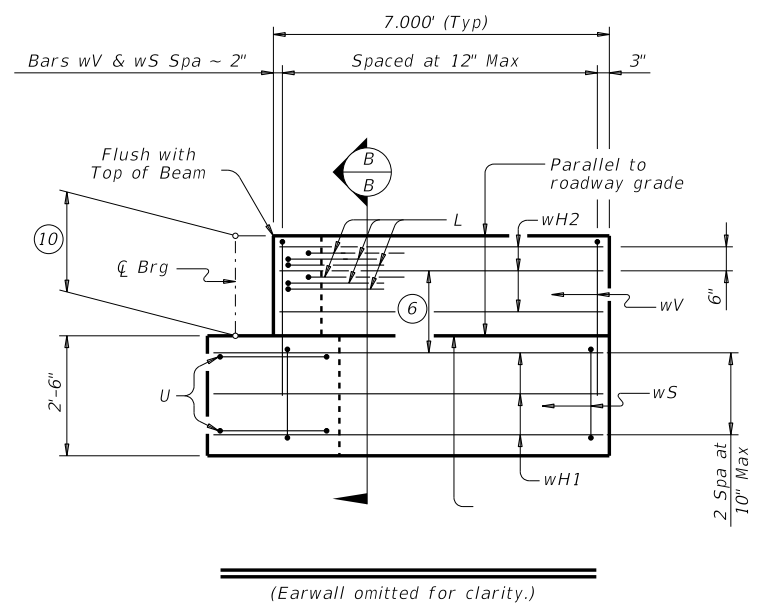
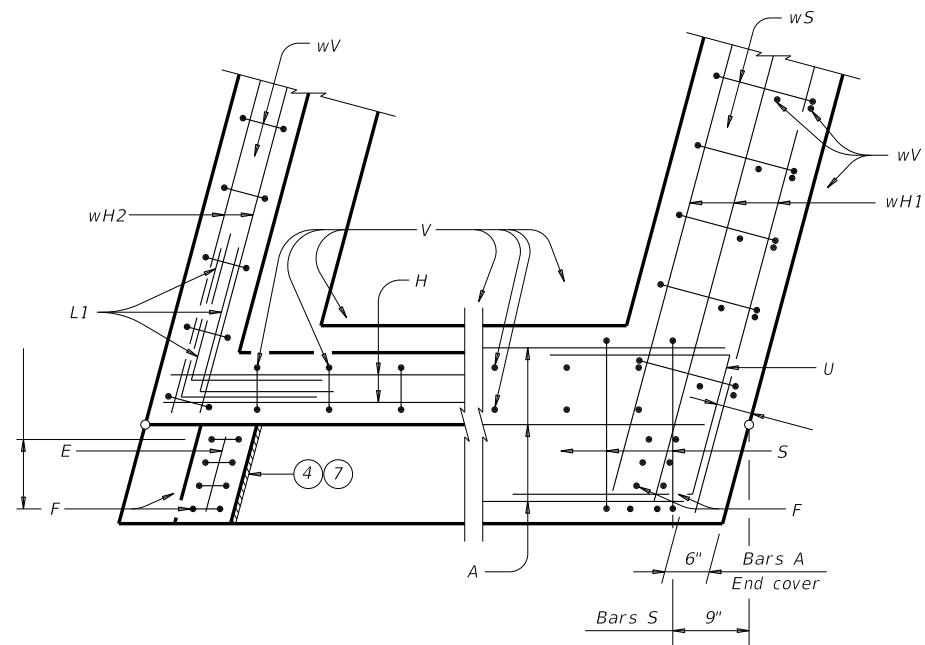

BARS F

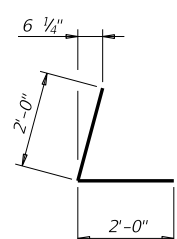

BARS L1

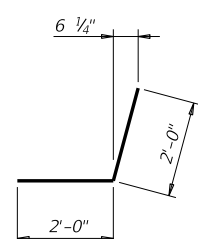

BARS L2

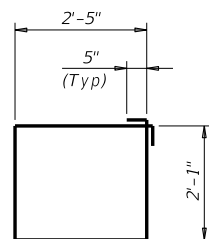

BARS S

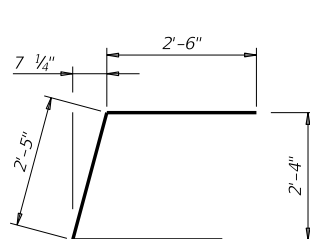

BARS U

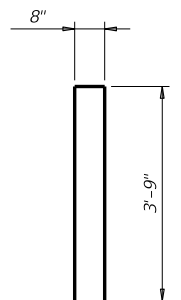

BARS V and wV

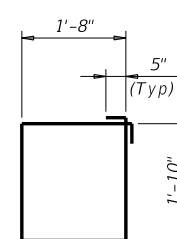

BARS wS

- ③ placed between piles. Deduct 59 Lbs from reinforcing steel total.
- ④ 1/2" preformed bituminous fiber material between beam stem and earwall. Bond to beam with an approved adhesive. Cast inside face of earwall cast with face of beam stem.
- ⑥ 2 spaces at 12" Max.
- ⑦ Do not cast earwalls until beams are erected in their final position.
- ⑨ Quantities shown are for one abutment only.
- 1'-10" for 8DS20 beams, 2'-1" for 8DS23 beams.

		<b>Bridge Division Standard</b>	
<b>ABUTMENTS</b> <b>PRESTRESSED CONCRETE</b> <b>DECKED SLAB BEAMS</b> <b>30' ROADWAY      15° SKEW</b>			
<b>ADSB-30-15</b>			
FILE:	DN:	CK:	DW:
① TxDOT	CONT	SECT	JOB
REVISIONS		HIGHWAY	
DIST		COUNTY	
		SHEET NO.	