

DISCLAIMER: The use of this standard is governed by the "Texas Engineering Practice Act". No warranty of any kind is made by TxDOT for any purpose whatsoever. TxDOT assumes no responsibility for the conversion of this standard to other formats or for incorrect results or damages resulting from its use.

DATE:
FILE:

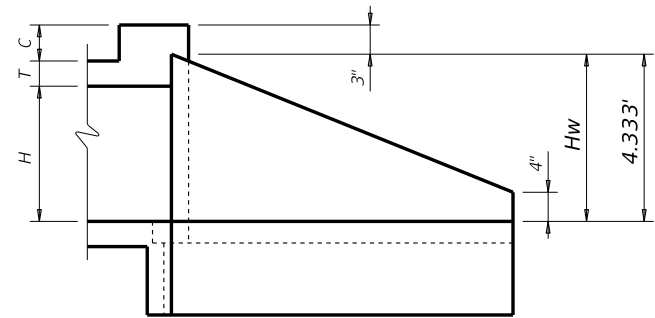

WINGWALL ELEVATION

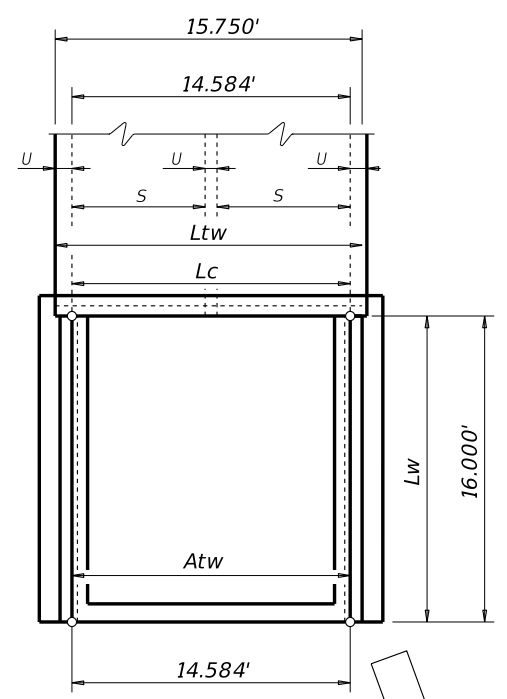

STRAIGHT END PLAN

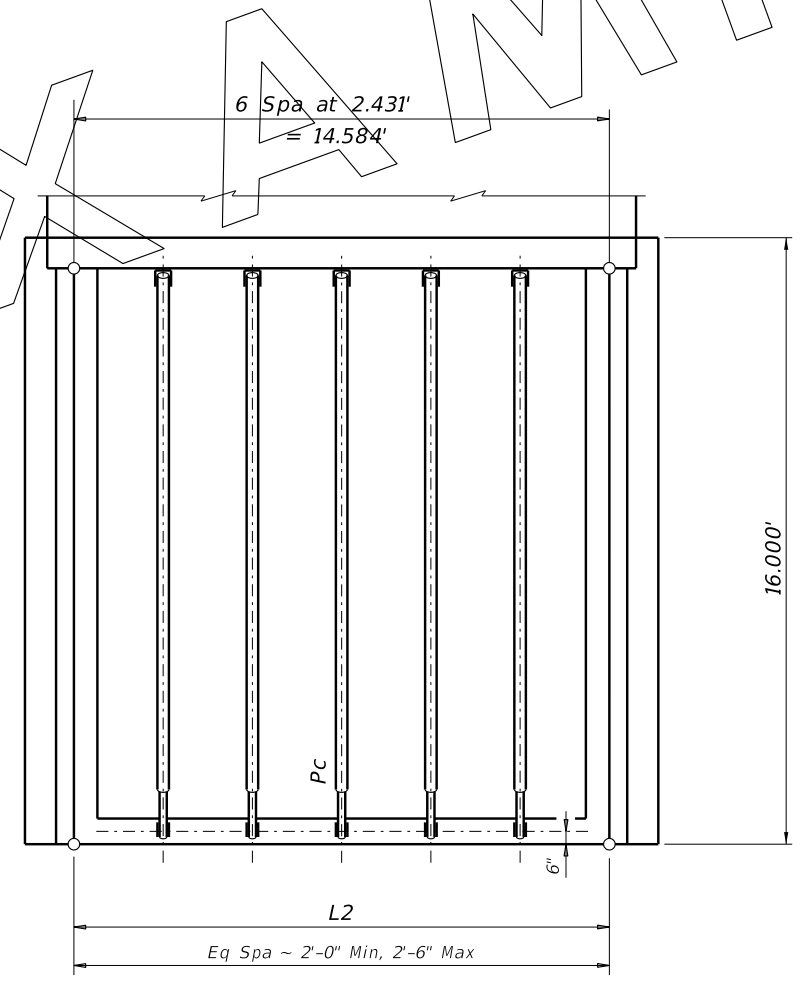

PIPE RUNNER PLAN

CONCRETE DIMENSIONS:

$$\begin{aligned}
 Hw &= H + T + C - 0.250' \\
 &= (3.000') + (0.583') + (1.000') - (0.250') \\
 &= 4.333' \\
 Lw &= (Hw - 0.333') (SL) \\
 &= (4.333' - 0.333') (4) \\
 &= 16.000' \\
 Ltw &= (N) (S) + (N+1) (U) \\
 &= (2) (7.000') + (2+1) (0.583') \\
 &= 15.750' \\
 Lc &= (Ltw) - (2U) \\
 &= (15.750') - (2) (0.583') \\
 &= 14.584' \\
 Atw &= Lc \\
 &= 14.584' \\
 \text{Total Wing Area} &= (Lw) (Hw + 0.333') \\
 &= (16.000') (4.333' + 0.333') \\
 &= 74.656' \text{ SF} \sim (\text{Two wings})
 \end{aligned}$$

PIPE LOCATIONS AND DIMENSIONS:

Establish Pipe Runner Spacing
 $(14.584') \div (2.500' \text{ max})$
 $= 5.8 \sim 6 \text{ spaces}$
 $(14.584') \div (6)$
 $= 2.431'$

Use:
 $L2 = \text{runner spacing at curb and at anchor toewall}$
 $= 6 \text{ spa at } 2.431' = 14.584'$

Establish Pipe Runner Length and Size:
 $Pc = (Lw) (K1) - (1.688' \text{ end of pipe clearance})$
 $= (16.000') (1.031) - (1.688')$
 $= 14.808'$

Test: $(Pc) > (9.333' \text{ Max length } 3'' \text{ pipe runner})$
 $(14.808') > (9.333')$
 $= \text{yes, do not use } 3'' \text{ pipe runner}$

Test: $(Pc) > (19.000' \text{ Max length } 4'' \text{ pipe})$
 $(14.808') > (19.000')$
 $= \text{no, use } 4'' \text{ pipe runner and } 3'' \text{ anchor pipe}$

BOX CULVERT PARAMETERS:

2 ~ 7' x 3' multi-box culvert with 8' fill, 4:1 slope, and 1.000' curb (C). From MC-7-10 Std: H = 3.000', T = 0.583', and U = 0.583'.

DEFINITIONS:

- Hw = Wingwall height (at tallest point) (feet)
- H = Interior height of culvert box (feet)
- T = Culvert slab thickness (feet)
- C = Height of curb above top of top slab (feet)
- Lw = Length of wingwall (feet)
- SL:1 = Side slope ratio (horizontal : 1 vertical)
- SL:1 Slope Angle
- 3:1 = 18.4349°
- 4:1 = 14.0362°
- 6:1 = 9.4623°
- K = Constant values for use in formulas
- SL:1 K1
- 3:1 = 1.054
- 4:1 = 1.031
- 6:1 = 1.014
- Note: $K1 = (1 \div \cos(\text{slope angle}))$
- Atw = Anchor toewall length (along outside face of toewall) (feet)
- N = Number of culvert spans (feet)
- S = Interior width of culvert span (feet)
- U = Thickness of culvert wall (feet)
- Ltw = Length of culvert toewall (feet)
- Lc = Length of culvert curb between wings (feet)
- Pc = Length of pipe runner on curb (feet)

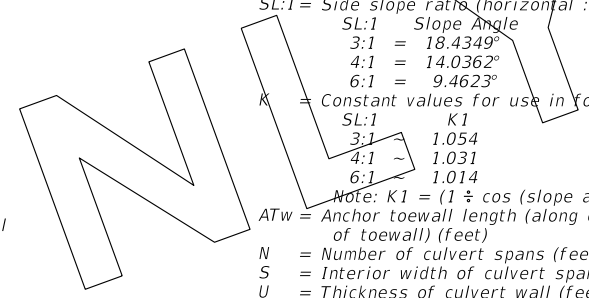

EXAMPLE CALCULATIONS FOR SETB-SW-O STANDARD

NOT A STANDARD
NOT FOR INCLUSION
IN THE PLANS

FILE: exstde2-20.dgn	DN: GAF	CK: CAT	DW: TxDOT	CK: TxDOT
©TxDOT February 2020	CONT	SECT	JOB	HIGHWAY
REVISIONS				
	DIST	COUNTY		SHEET NO.

DISCLAIMER:
 The use of this standard is governed by the "Texas Engineering Practice Act". No warranty of any kind is made by TxDOT for any purpose whatsoever. TxDOT assumes no responsibility for the conversion of this standard to other formats or for incorrect results or damages resulting from its use.

DATE:
 FILE:

Culvert Station and/or Creek name followed by applicable end (Lt, Rt or Both) (11)	Lc (Ft)	L2			Pipe Runner (Pc)				3'-0" Anchor Pipe	
		No. Spa	Spa at (Ft)	Overall Length (Ft)	No.	Length (Ft)	Size (3", 4" or 5")	Total Length (Ft) (11)	Size (2", 3" or 4")	Total Length (Ft) (11)
Velma Gulch (Both)	14.584'	6	2.431'	14.584'	5	14.808'	4"	148.080'	3"	30.000'

ONLY

(11) Quantities shown are for one structure end if Lt or Rt. Quantities shown are for two structure ends if both.

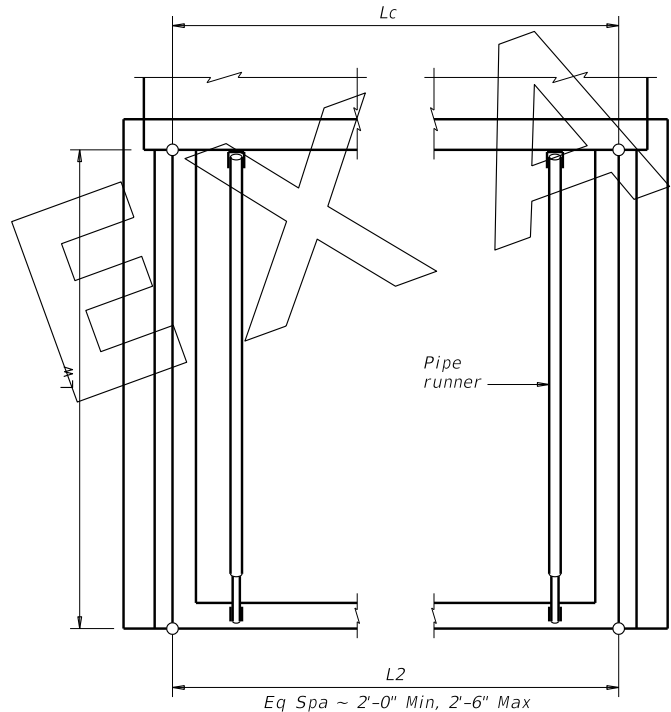

PIPE RUNNER LAYOUT

SPECIAL NOTE:
 This tabular sheet is to be filled out by the culvert specifier and provides information for the construction details and quantities of pipe runners.
 An Excel 2010 spreadsheet to assist in completing this table can be downloaded from the Bridge Standards (English) web page on the TxDOT web site. The completed sheet must be signed, sealed, and dated by a licensed Professional Engineer.
 Note that the tabular quantities are given for estimating purposes only. It is likely that these quantities will change due to field conditions. Therefore, all dimensions must be verified by the Contractor in the field prior to fabrication of the safety end treatment components.

NOT A STANDARD
 NOT FOR INCLUSION
 IN THE PLANS

SHEET 2 OF 2

				Bridge Division Standard	
EXAMPLE OF COMPLETED SHEET 3 OF 3 SETB-SW-O STANDARD					
FILE: exstde02-20.dgn	DN: TxDOT	CK: TxDOT	DW: TxDOT	CK: TxDOT	
©TxDOT February 2020	CONT	SECT	JOB	HIGHWAY	
REVISIONS					
	DIST	COUNTY	SHEET NO.		