

DISCLAIMER: The use of this standard is governed by the "Texas Engineering Practice Act". No warranty of any kind is made by TxDOT for any purpose whatsoever. TxDOT assumes no responsibility for the conversion of this standard to other formats or for incorrect results or damages resulting from its use.

DATE: FILE:

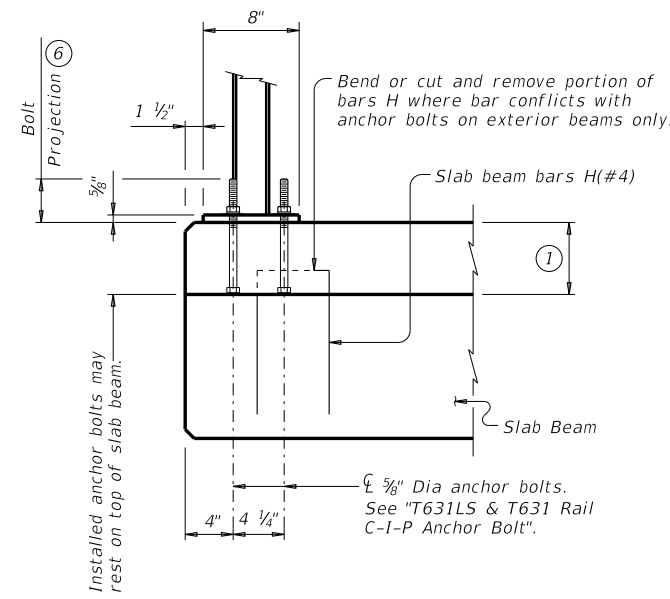

CAST-IN-PLACE ANCHORAGE OPTION

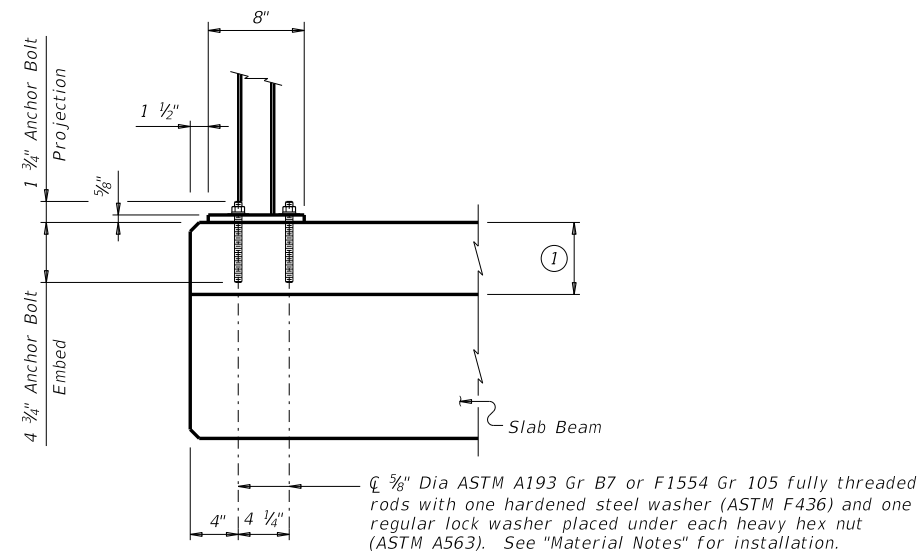

ADHESIVE ANCHORAGE OPTION

**T631LS & T631 RAIL ANCHORAGE PLACEMENT (2)(7)**

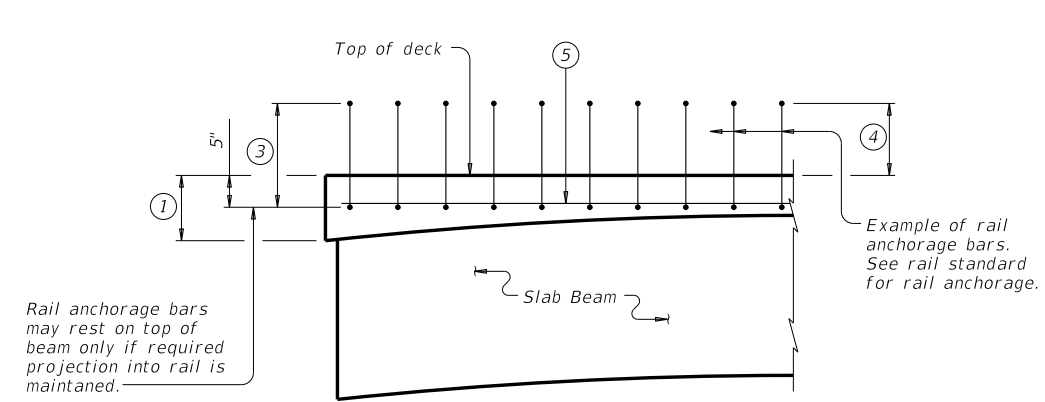

PART SPAN ELEVATION

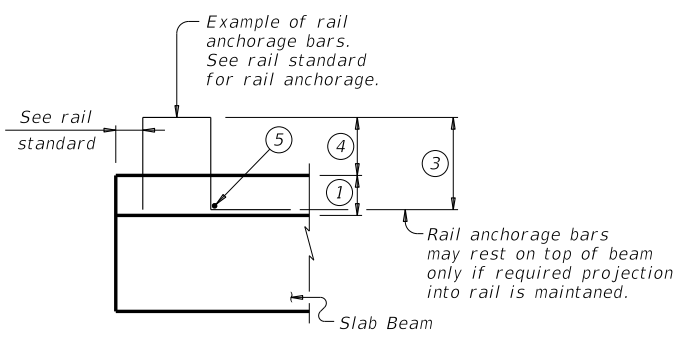

SECTION

**TYPICAL CONCRETE RAIL ANCHORAGE**

(Showing typical concrete rail anchorage)

5/8" Dia heavy hex head anchor bolt (ASTM F3125 Gr A325 or A449) with one hardened steel washer (ASTM F436) and one regular lock washer placed under heavy hex nut (ASTM A563).

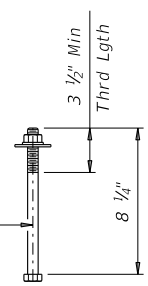

**T631LS & T631 RAIL C-I-P ANCHOR BOLT**

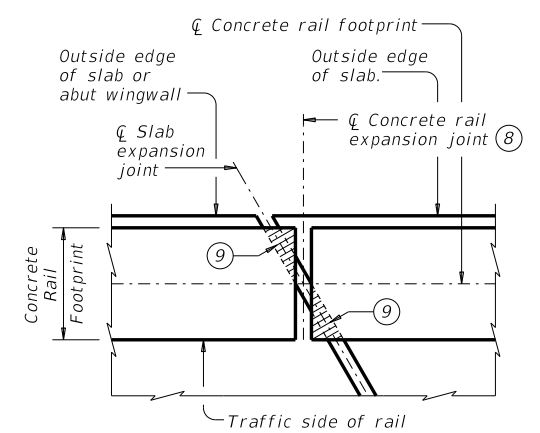

**PLAN OF CONCRETE RAILS AT EXPANSION JOINTS**

- ① Cast-in-place slab thickness varies due to beam camber (5" minimum).
- ② Replace cast-in-place anchor bolts shown on T631LS and T631 Rail standard with an adhesive anchor system or cast-in-place anchor bolts shown on this sheet.
- ③ Bar length shown on rail standard, minus 1 1/4". Adjust bar length for a raised sidewalk.
- ④ See rail standard for projection from finished grade or top of sidewalk.
- ⑤ Place additional (#5) longitudinal bar.
- ⑥ Excess bolt length has been provided to accommodate a variable slab thickness due to beam camber. If slab thickness on span details exceed 7", bolt length must be increased accordingly. After posts have been set and bolts tightened, bolt projection above nuts of more than 1/2" must be cut off and painted with two coats of zinc-rich paint conforming to the Item 445 "Galvanizing".
- ⑦ Distance from end of top outside edge of slab to center of first bolt group can not be less than 9", except: 15° Skew: 1'-0" (acute corner only)  
30° Skew: 1'-3" (acute corner only)
- ⑧ Location of rail expansion joint must be at the intersection of slab expansion joint, rail footprint and perpendicular to slab outside edge.
- ⑨ Cross-hatched area must have 1/2" preformed bituminous fiber material under concrete rail, as shown.

**CONSTRUCTION NOTES:**

Rail anchorage bars may be field bent as required to clear rail reinforcing or provide minimum cover shown on standard rail detail sheets.  
 Test adhesive anchors in accordance with Item 450.3.3, "Tests". Test 3 anchors per 100 anchors installed. Perform corrective measures to provide adequate capacity if any of the tests do not meet the required test load. Repair damage from testing as directed.

**MATERIAL NOTES:**

Galvanize all steel components of steel rail system.  
 Provide Grade 60 reinforcing steel.  
 Cast-in-place anchorage system for T631LS and T631 Rail must be 5/8" Dia heavy hex head anchor bolts (ASTM F3125 Gr 325 or A449) with one hardened steel washer (ASTM F436) and one regular lock washer placed under heavy hex nut. Nuts must conform to ASTM A563 requirements. Embed anchor bolts 4 1/2" minimum.  
 Adhesive anchors for T631LS and T631 Rail must be 5/8" Dia ASTM A193 Gr B7 or F1554 Gr 105 fully threaded rods with one hardened steel washer (ASTM F436) and one regular lock washer placed under each heavy hex nut. Nuts must conform to ASTM A563 requirements. Embed fully threaded rod into slab and/or abutment wingwall using a Type III, Class C, D, E, or F anchor adhesive. Minimum adhesive anchor embedment depth is 4 3/4". Anchor adhesive chosen must be able to achieve a nominal bond strength in tension of a single anchor, Na, of 8 kips (edge distance must be accounted for). Submit signed and sealed calculations or the manufacturer's published literature showing the proposed anchor adhesive's ability to develop this load to the Engineer for approval prior to use. Anchor installation, including hole size, drilling, and clean out, must be in accordance with Item 450, "Railing."  
 Epoxy coat or galvanize reinforcing steel shown on this standard if rail reinforcement is epoxy coated or galvanized.

**GENERAL NOTES:**

Designed in accordance with AASHTO LRFD Bridge Design Specifications.  
 This standard is for use with structures with a 5" minimum cast-in-place concrete slab.  
 This standard may require modification for interior rails. This standard does not apply to median barriers.  
 This standard does not provide details for Type T221P, T224, T80HT, T80SS, C412, PR11, PR22 and PR3 rails on slab beam bridges.  
 See rail standards for approved speed restrictions, notes and details not shown.

Cover dimensions are clear dimensions, unless noted otherwise.

		<b>Bridge Division Standard</b>	
<b>RAIL ANCHORAGE DETAILS</b>			
<b>PRESTR CONCRETE SLAB BEAMS</b>			
<b>PSBRA</b>			
FILE: psbste07-18.dgn	DN: TxDOT	CK: TxDOT	DW: JTR
©TxDOT January 2017	CONT	SECT	JOB
REVISIONS		HIGHWAY	
03-18: Updated adhesive anchor notes.		DIST	COUNTY
		SHEET NO.	