

DISCLAIMER: The use of this standard is governed by the "Texas Engineering Practice Act". No warranty of any kind is made by TxDOT for any purpose whatsoever. TxDOT assumes no responsibility for the conversion of this standard to other formats or for incorrect results or damages resulting from its use.

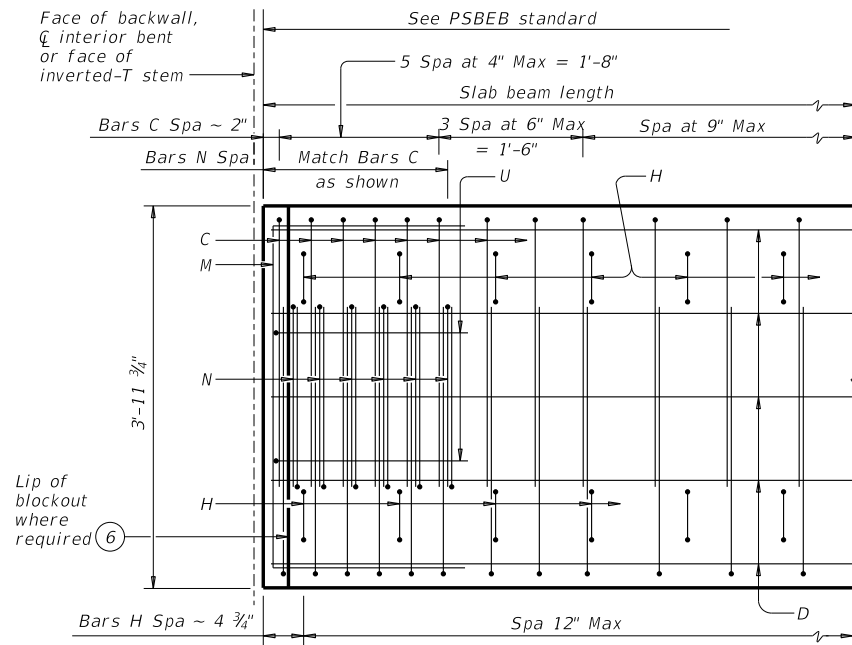

PART PLAN

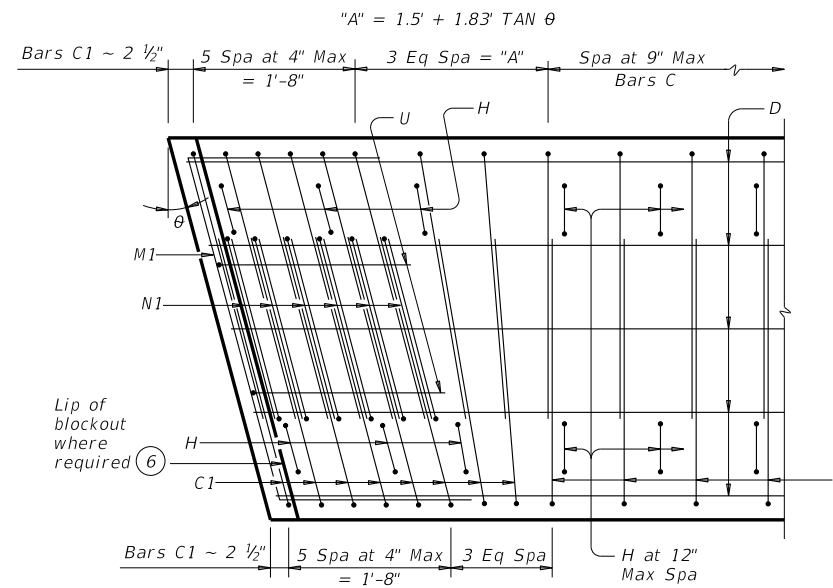

PART SKEW PLAN

(Showing θ over 0° to 15° Skew)

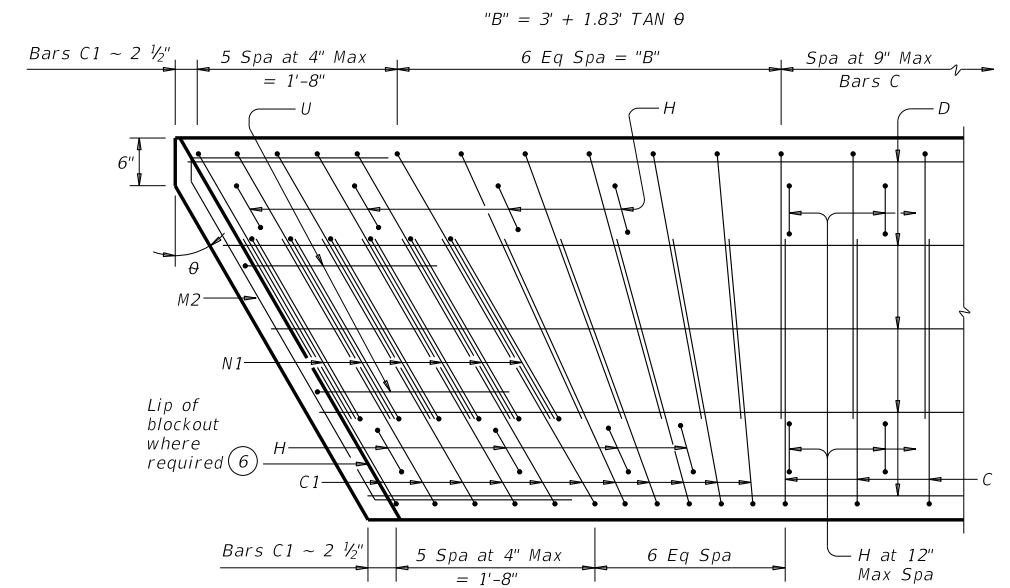

PART SKEW PLAN

(Showing θ over 15° to 30° Skew)

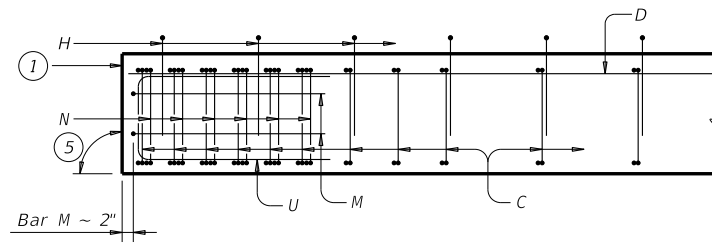

ELEVATION

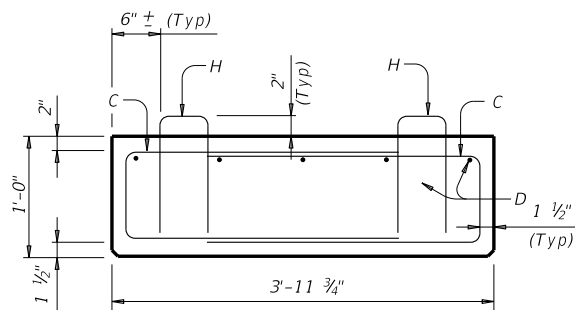

SECTION

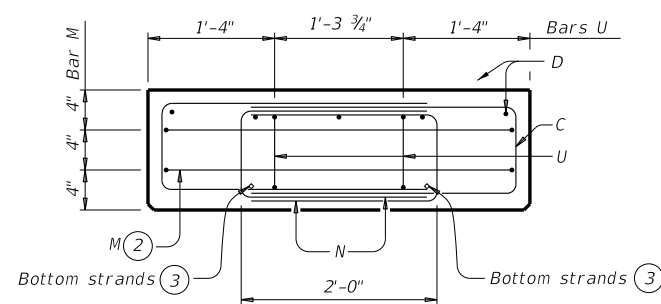

END MAT REINFORCING

Bars H not shown for clarity.

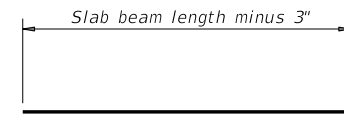

BARS D(#6)



BARS M(#4)

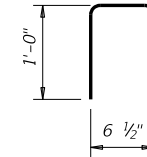

BARS H(#4)

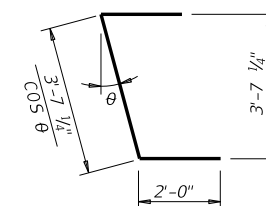

BARS M1(#4)

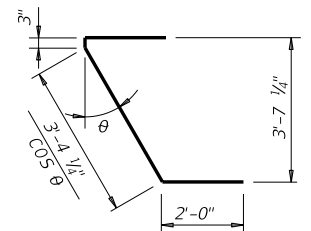

BARS M2(#4)

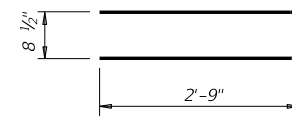

BARS C(#4)

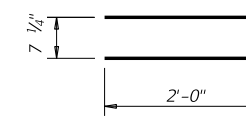

BARS U(#5)

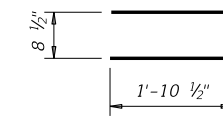

BARS N(#4)

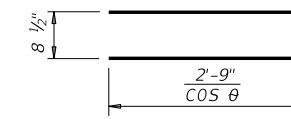

BARS C1(#4)

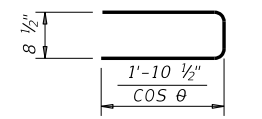

BARS N1(#4)

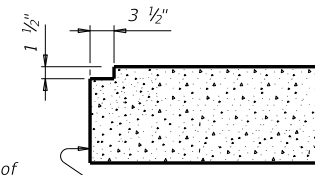

ELEVATION OF BLOCKOUT (6)

BEAM PROPERTIES

Area	in ²	573.0
Y top	in	6.00
Y bott	in	6.00
I	in ⁴	6,876
Weight (4)	lb/ft	597

GENERAL NOTES:

- Designed according to AASHTO LRFD Bridge Design Specifications. Provide Class H concrete. Provide Class H (HPC) if shown elsewhere in the plans.
- Provide Grade 60 reinforcing steel.
- An equal area of welded wire reinforcement (WWR) (ASTM 1064) may be substituted for bars C and D if approved by the Engineer.
- These details can be used for any skew angle up to a maximum of 30 degrees.
- Chamfer all exposed corners 3/4" or round to a 3/4" radius.
- Details are drawn showing right forward skew. See Bridge Layout for actual direction.

Cover dimensions are clear dimensions, unless noted otherwise.
Reinforcing bar dimensions shown are out-to-out of bar.

- (1) See End Mat Reinforcing detail.
- (2) Adjust bars M vertically to avoid strands.
- (3) See sheet PSBND or PSBSD for strand locations.
- (4) Assumes 150 pcf weight density of concrete.
- (5) 90° at conventional interior bents. End of beam must be vertical at abutment backwall and inverted-T stem.
- (6) Blockout required at armor joint (AJ) and sealed expansion joint (SEJ) locations to accommodate joint anchorage.

HL93 LOADING

Texas Department of Transportation
Bridge Division Standard

PRESTRESSED CONCRETE SLAB BEAM DETAILS

(TYPE 4SB12)

PSB-4SB12

FILE: psbsts01-17.dgn	DN: TxDOT	CK: TxDOT	DW: TxDOT	CK: TxDOT
©TxDOT January 2017	CONT	SECT	JOB	HIGHWAY
REVISIONS				
DIST	COUNTY		SHEET NO.	

DATE: FILE: