

DISCLAIMER: The use of this standard is governed by the "Texas Engineering Practice Act". No warranty of any kind is made by TxDOT for any purpose whatsoever. TxDOT assumes no responsibility for the conversion of this standard to other formats or for incorrect results or damages resulting from its use.

DATE: FILE:

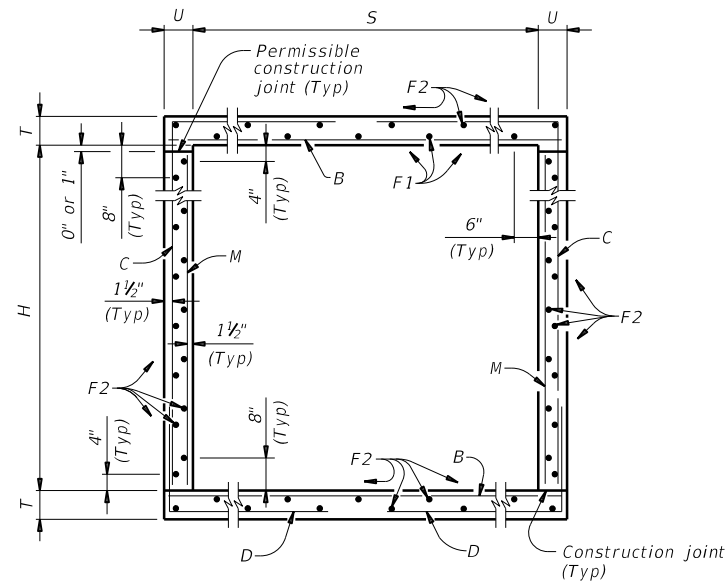

TYPICAL SECTION

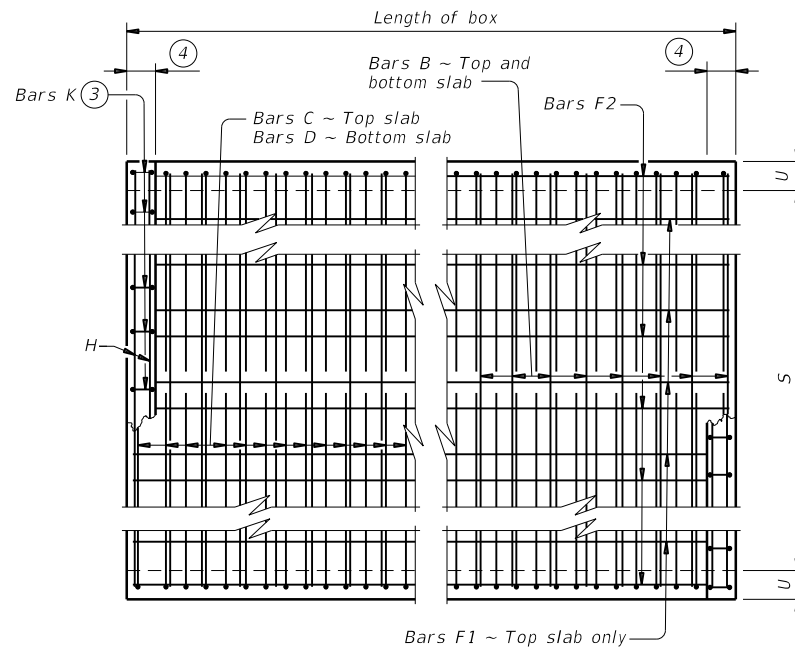

PLAN OF REINF STEEL

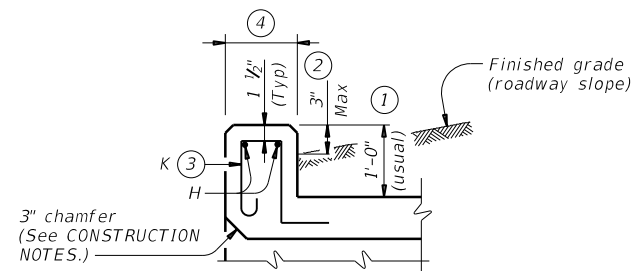

SECTION THRU CURB

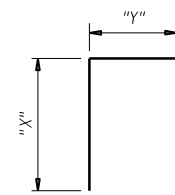

BARS C

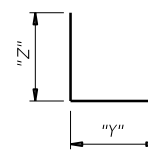

BARS D

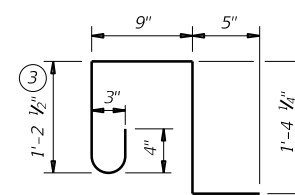

BARS K (#4)
(Spa = 1'-0" Max)
(Length = 4'-2")

- ① 0" Min to 5'-0" Max. Estimated curb heights are shown elsewhere in the plans. For structures with pedestrian rail or curbs taller than 1'-0", refer to the Extended Curb Details (ECD) standard sheet. For structures with T631 or T631LS bridge rail, refer to the Mounting Details for T631 & T631LS Rails (T631-CM) standard sheet. Refer to the Rail Anchorage Curb (RAC) standard sheet for structures with bridge rail other than T631 or T631LS.
- ② For vehicle safety, the following requirements must be met:
 - For structures without bridge rail, construct curbs no more than 3" above finished grade.
 - For structures with bridge rail, construct curbs flush with finished grade. Reduce curb heights, if necessary, to meet the above requirements. No changes will be made in quantities and no additional compensation will be allowed for this work.
- ③ For curbs less than 1'-0" high, tilt Bars K or reduce bar height as necessary to maintain cover. For curbs less than 3" high, Bars K may be omitted.
- ④ 1'-0" typical. 2'-3" when the Rail Anchorage Curb (RAC) standard sheet is referred to elsewhere in the plans.

The Contractor may replace Bars B, C, D, E, F1, F2, M, Y, and/or Z with deformed welded wire reinforcement (WWR) meeting the requirements of ASTM A1064. The area of required reinforcement may be reduced by the ratio of 60 ksi / 70 ksi. Spacing of WWR is limited to 4" Min and 18" Max. When required, provide lap splices in the WWR of the same length required for the equivalent bar size, rounded up for wire sizes between conventional bar sizes. The lap length required for WWR is never less than the lap length required for uncoated #4 bars.

Example conversion: Replacing No. 6 Gr 60 at 6" Spacing with WWR.
Required WWR = (0.44 sq. in. per 0.5 ft.) x (60 ksi / 70 ksi) = 0.755 sq. in. per ft.
If D30.6 wire is used to meet the 0.755 sq. in. per ft. requirement in this example, the required spacing = (0.306 sq. in.) / (0.755 sq. in. per ft.) x (12 in. per ft.) = 4.86" Max spacing. Required lap length for the provided D30.6 wire is 2'-1" (the same minimum lap length required for uncoated #5 bars, as listed under MATERIAL NOTES).

CONSTRUCTION NOTES:

- Do not use permanent forms.
- Chamfer the bottom edge of the top slab 3" at the entrance.
- Optionally, raise construction joints shown at the flow line by a maximum of 6". If this option is taken, Bars M may be cut off or raised, Bars C and D may be reversed.

MATERIAL NOTES:

- Provide Grade 60 reinforcing steel.
- Provide galvanized reinforcing steel if required elsewhere in the plans.
- Provide Class C concrete ($f'_c = 3,600$ psi) for culvert barrel and curb, with the following exceptions: provide Class S concrete ($f'_c = 4,000$ psi) for top slabs of:
 - culverts with overlay,
 - culverts with 1-to-2 course surface treatment, or
 - culverts with the top slab as the final riding surface.
- Provide bar laps, where required, as follows:
 - Uncoated or galvanized ~ #4 = 1'-8" Min
 - Uncoated or galvanized ~ #5 = 2'-1" Min
 - Uncoated or galvanized ~ #6 = 2'-6" Min

GENERAL NOTES:

- Designed according to AASHTO LRFD Bridge Design Specifications for the range of fill heights shown.
- See the Single Box Culverts Cast-In-Place Miscellaneous Detail (SCC-MD) standard sheet for details pertaining to skewed ends, angle sections, and lengthening.

Cover dimensions are clear dimensions, unless noted otherwise.
Reinforcing bar dimensions shown are out-to-out of bar.



**SINGLE BOX CULVERTS
CAST-IN-PLACE
0' TO 30' FILL**

SCC-7

FILE: scc07ste-21.dgn	DN: TBE	CK: BMP	DW: TxDOT	CK: TxDOT
©TxDOT February 2020	CONT	SECT	JOB	HIGHWAY
REVISIONS				
04/2021 Updated X values.	DIST	COUNTY	SHEET NO.	

DISCLAIMER: The use of this standard is governed by the "Texas Engineering Practice Act". No warranty of any kind is made by TxDOT for any purpose whatsoever. TxDOT assumes no responsibility for the conversion of this standard to other formats or for incorrect results or damages resulting from its use.

DATE:
 FILE:

SECTION DIMENSIONS				FILL HEIGHT ⁵	BILLS OF REINFORCING STEEL (For Box Length = 40 feet)																								QUANTITIES														
					Bars B					Bars C					Bars D					Bars M ~ #4				Bars F1 ~ #4 at 18" Spa			Bars F2 ~ #4 at 18" Spa			Bars H 4 ~ #4		Bars K		Per Foot of Barrel		Curb		Total					
					S	H	T	U	No.	Size	Spa	Length	Weight	No.	Size	Spa	Length	Weight	" X "	" Y "	No.	Size	Spa	Length	Weight	" Y "	" Z "	No.	Spa	Length	Weight	No.	Length	Wt	No.	Length	Weight	Length	Wt	No.	Wt	Conc (CY)	Reinf (Lb)
7'-0"	3'-0"	8"	7"	16'	108	#6	9"	7'-11"	1,284	162	#5	6"	7'-11"	1,338	3'-6"	4'-5"	162	#5	6"	7'-11"	1,197	4'-5"	2'-8"	108	9"	3'-0"	216	5	39'-9"	133	31	39'-9"	823	7'-11"	21	18	50	0.533	124.8	0.6	71	21.9	5,062
7'-0"	3'-0"	9"	7"	20'	108	#6	9"	7'-11"	1,284	162	#5	6"	8'-0"	1,352	3'-7"	4'-5"	162	#5	6"	7'-2"	1,211	4'-5"	2'-9"	108	9"	3'-0"	216	5	39'-9"	133	31	39'-9"	823	7'-11"	21	18	50	0.583	125.5	0.6	71	23.9	5,090
7'-0"	3'-0"	10"	8"	23'	108	#6	9"	8'-1"	1,311	162	#5	6"	8'-2"	1,380	3'-8"	4'-6"	162	#5	6"	7'-4"	1,239	4'-6"	2'-10"	82	12"	3'-0"	164	5	39'-9"	133	31	39'-9"	823	8'-1"	22	20	56	0.663	126.3	0.6	78	27.1	5,128
7'-0"	3'-0"	11"	8"	30'	108	#6	9"	8'-1"	1,311	162	#5	6"	8'-3"	1,394	3'-9"	4'-6"	162	#5	6"	7'-5"	1,253	4'-6"	2'-11"	82	12"	3'-0"	164	5	39'-9"	133	31	39'-9"	823	8'-1"	22	20	56	0.714	127.0	0.6	78	29.2	5,156
7'-0"	4'-0"	8"	7"	16'	108	#6	9"	7'-11"	1,284	162	#5	6"	8'-11"	1,507	4'-6"	4'-5"	162	#5	6"	7'-1"	1,197	4'-5"	2'-8"	108	9"	4'-0"	289	5	39'-9"	133	31	39'-9"	823	7'-11"	21	18	50	0.576	130.8	0.6	71	23.6	5,304
7'-0"	4'-0"	9"	7"	20'	108	#6	9"	7'-11"	1,284	162	#5	6"	9'-0"	1,521	4'-7"	4'-5"	162	#5	6"	7'-2"	1,211	4'-5"	2'-9"	108	9"	4'-0"	289	5	39'-9"	133	31	39'-9"	823	7'-11"	21	18	50	0.627	131.5	0.6	71	25.7	5,332
7'-0"	4'-0"	10"	8"	23'	108	#6	9"	8'-1"	1,311	162	#5	6"	9'-2"	1,549	4'-8"	4'-6"	162	#5	6"	7'-4"	1,239	4'-6"	2'-10"	82	12"	4'-0"	219	5	39'-9"	133	31	39'-9"	823	8'-1"	22	20	56	0.712	131.9	0.6	78	29.1	5,352
7'-0"	4'-0"	11"	8"	30'	162	#6	6"	8'-1"	1,967	162	#5	6"	9'-3"	1,563	4'-9"	4'-6"	162	#5	6"	7'-5"	1,253	4'-6"	2'-11"	82	12"	4'-0"	219	5	39'-9"	133	31	39'-9"	823	8'-1"	22	20	56	0.763	149.0	0.6	78	31.1	6,036
7'-0"	5'-0"	8"	7"	16'	108	#6	9"	7'-11"	1,284	162	#5	6"	9'-11"	1,676	5'-6"	4'-5"	162	#5	6"	7'-1"	1,197	4'-5"	2'-8"	108	9"	5'-0"	361	5	39'-9"	133	35	39'-9"	929	7'-11"	21	18	50	0.619	139.5	0.6	71	25.4	5,651
7'-0"	5'-0"	9"	7"	20'	108	#6	9"	7'-11"	1,284	162	#5	6"	10'-0"	1,690	5'-7"	4'-5"	162	#5	6"	7'-2"	1,211	4'-5"	2'-9"	108	9"	5'-0"	361	5	39'-9"	133	35	39'-9"	929	7'-11"	21	18	50	0.670	140.2	0.6	71	27.4	5,679
7'-0"	5'-0"	10"	8"	23'	108	#6	9"	8'-1"	1,311	162	#5	6"	10'-2"	1,718	5'-8"	4'-6"	162	#5	6"	7'-4"	1,239	4'-6"	2'-10"	82	12"	5'-0"	274	5	39'-9"	133	35	39'-9"	929	8'-1"	22	20	56	0.761	140.1	0.6	78	31.1	5,682
7'-0"	5'-0"	11"	8"	30'	162	#6	6"	8'-1"	1,967	162	#5	6"	10'-3"	1,732	5'-9"	4'-6"	162	#5	6"	7'-5"	1,253	4'-6"	2'-11"	82	12"	5'-0"	274	5	39'-9"	133	35	39'-9"	929	8'-1"	22	20	56	0.813	157.2	0.6	78	33.1	6,366
7'-0"	6'-0"	8"	7"	16'	108	#6	9"	7'-11"	1,284	162	#5	6"	10'-11"	1,845	6'-6"	4'-5"	162	#5	6"	7'-1"	1,197	4'-5"	2'-8"	108	9"	6'-0"	433	5	39'-9"	133	39	39'-9"	1,036	7'-11"	21	18	50	0.663	148.2	0.6	71	27.1	5,999
7'-0"	6'-0"	9"	7"	20'	108	#6	9"	7'-11"	1,284	162	#5	6"	11'-0"	1,859	6'-7"	4'-5"	162	#5	6"	7'-2"	1,211	4'-5"	2'-9"	108	9"	6'-0"	433	5	39'-9"	133	39	39'-9"	1,036	7'-11"	21	18	50	0.713	148.9	0.6	71	29.1	6,027
7'-0"	6'-0"	10"	8"	23'	108	#6	9"	8'-1"	1,311	162	#5	6"	11'-2"	1,887	6'-8"	4'-6"	162	#5	6"	7'-4"	1,239	4'-6"	2'-10"	82	12"	6'-0"	329	5	39'-9"	133	39	39'-9"	1,036	8'-1"	22	20	56	0.811	148.4	0.6	78	33.1	6,013
7'-0"	6'-0"	11"	8"	30'	162	#6	6"	8'-1"	1,967	162	#5	6"	11'-3"	1,901	6'-9"	4'-6"	162	#5	6"	7'-5"	1,253	4'-6"	2'-11"	82	12"	6'-0"	329	5	39'-9"	133	39	39'-9"	1,036	8'-1"	22	20	56	0.862	165.5	0.6	78	35.1	6,697
7'-0"	7'-0"	8"	7"	16'	108	#6	9"	7'-11"	1,284	162	#5	6"	11'-11"	2,014	7'-6"	4'-5"	162	#5	6"	7'-1"	1,197	4'-5"	2'-8"	108	9"	7'-0"	505	5	39'-9"	133	39	39'-9"	1,036	7'-11"	21	18	50	0.706	154.2	0.6	71	28.8	6,240
7'-0"	7'-0"	9"	7"	20'	108	#6	9"	7'-11"	1,284	162	#5	6"	12'-0"	2,028	7'-7"	4'-5"	162	#5	6"	7'-2"	1,211	4'-5"	2'-9"	108	9"	7'-0"	505	5	39'-9"	133	39	39'-9"	1,036	7'-11"	21	18	50	0.756	154.9	0.6	71	30.8	6,268
7'-0"	7'-0"	10"	8"	23'	108	#6	9"	8'-1"	1,311	162	#5	6"	12'-2"	2,056	7'-8"	4'-6"	162	#5	6"	7'-4"	1,239	4'-6"	2'-10"	108	9"	7'-0"	505	5	39'-9"	133	39	39'-9"	1,036	8'-1"	22	20	56	0.860	157.0	0.6	78	35.0	6,358
7'-0"	7'-0"	11"	8"	30'	162	#6	6"	8'-1"	1,967	162	#5	6"	12'-3"	2,070	7'-9"	4'-6"	162	#5	6"	7'-5"	1,253	4'-6"	2'-11"	108	9"	7'-0"	505	5	39'-9"	133	39	39'-9"	1,036	8'-1"	22	20	56	0.912	174.1	0.6	78	37.1	7,042

⁵ For direct traffic culverts (fill height ≤ 2 ft.), identify the required box size and select the option with the minimum fill height.



**SINGLE BOX CULVERTS
CAST-IN-PLACE
0' TO 30' FILL**

SCC-7

FILE: scc07ste-21.dgn	DN: TBE	CK: BMP	DW: TxDOT	CK: TxDOT
©TxDOT February 2020	CONT	SECT	JOB	HIGHWAY
REVISIONS				
04/2021 Updated X values.	DIST	COUNTY	SHEET NO.	