

DISCLAIMER: The use of this standard is governed by the "Texas Engineering Practice Act". No warranty of any kind is made by TxDOT for any purpose whatsoever. TxDOT assumes no responsibility for the conversion of this standard to other formats or for incorrect results or damages resulting from its use.

DATE: FILE:

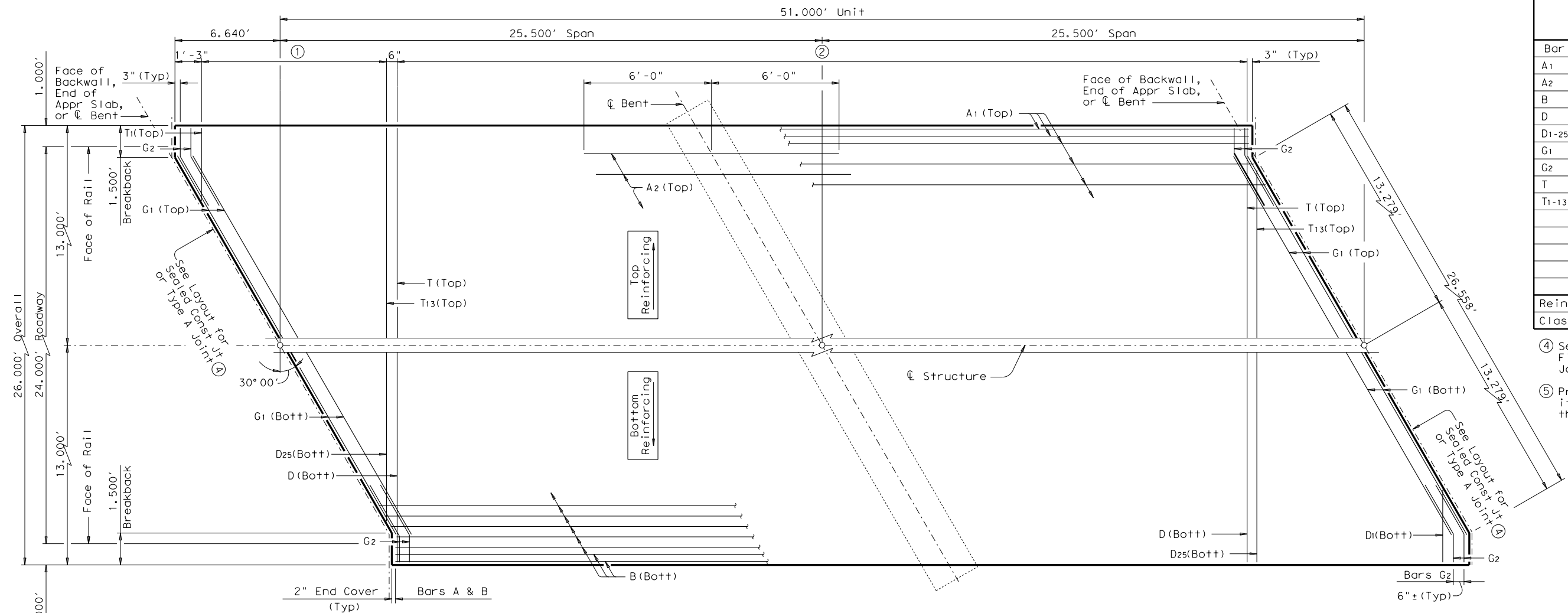

- ① Bars T1-13 (Top) at 12" Max Spacing = 11'-9 1/2"
- Bars D1-25 (Bott) at 6" Max Spacing = 11'-9 1/2"
- ② Bars T (Top) at 12" Max Spacing
- Bars D (Bott) at 6" Max Spacing

PLAN

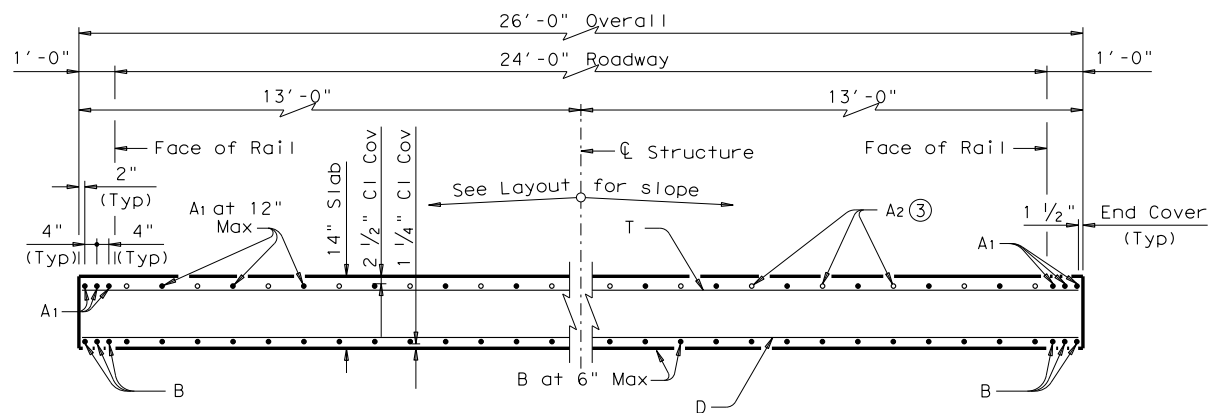
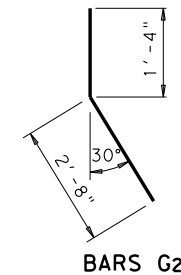

TYPICAL TRANSVERSE SECTION

③ Place Bars A2 between Bars A1 over Bent (See PLAN for Placement)

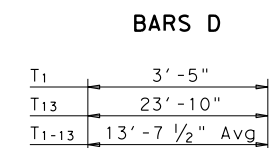
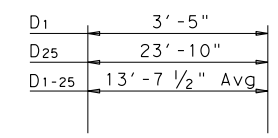

TABLE OF ESTIMATED QUANTITIES CS-50-24 (30°)

Bar	No.	Size	Length	Weight
A1	30	# 8	50' - 8"	4,058
A2	25	# 8	12' - 0"	801
B	54	# 8	50' - 8"	7,305
D	77	# 4	25' - 9"	1,324
D1-25	50	# 4	13' - 8" AV	456
G1	8	# 5	26' - 7"	222
G2	16	# 5	4' - 0"	67
T	39	# 4	25' - 9"	671
T1-13	26	# 4	13' - 8" AV	237

Reinforcing Steel	Lb	15,141
Class "S" Concrete ⑤	CY	57.5

- ④ See standard CS-MD for Fixed or Expansion Joint Details.
- ⑤ Provide Class S (HPC) if shown elsewhere in the plans.

GENERAL NOTES:
 Designed according to AASHTO LRFD Specifications.
 Details shown are for right forward skew. See Layout for actual skew direction. See standard CS-MD for additional slab span details.
 All reinforcing shall be Grade 60. Bar laps not permitted for Bars A and B. Concrete strength f'c = 4,000 psi. This standard does not support the use of Transition Bents.

HL93 LOADING

Texas Department of Transportation Bridge Division Standard

51' C-I-P CONTINUOUS SLAB UNIT
 (25.5'-25.5')
 24 FT ROADWAY 30° SKEW

CS-50-24-30

FILE: scs08ste.dgn	DN: TxDOT	CK: TxDOT	DW: TxDOT	CK: TxDOT
©TxDOT March 2009	CONT	SECT	JOB	HIGHWAY
REVISIONS				
	DIST	COUNTY		SHEET NO.