

DISCLAIMER: The use of this standard is governed by the "Texas Engineering Practice Act". No warranty of any kind is made by TxDOT for any purpose whatsoever. TxDOT assumes no responsibility for the conversion of this standard to other formats or for incorrect results or damages resulting from its use.

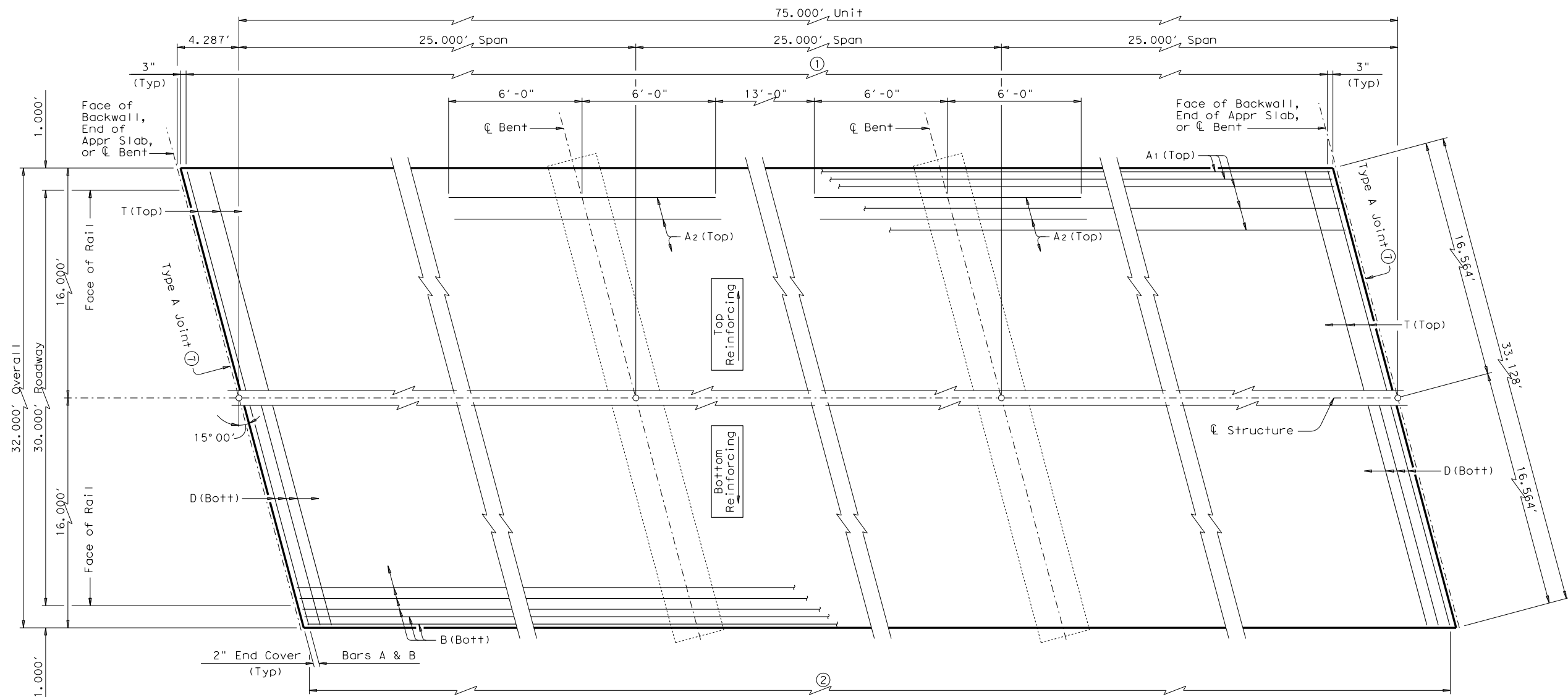

- ① Bars T (Top) at 12" Max Spacing
- ② Bars D (Bott) at 6" Max Spacing

PLAN

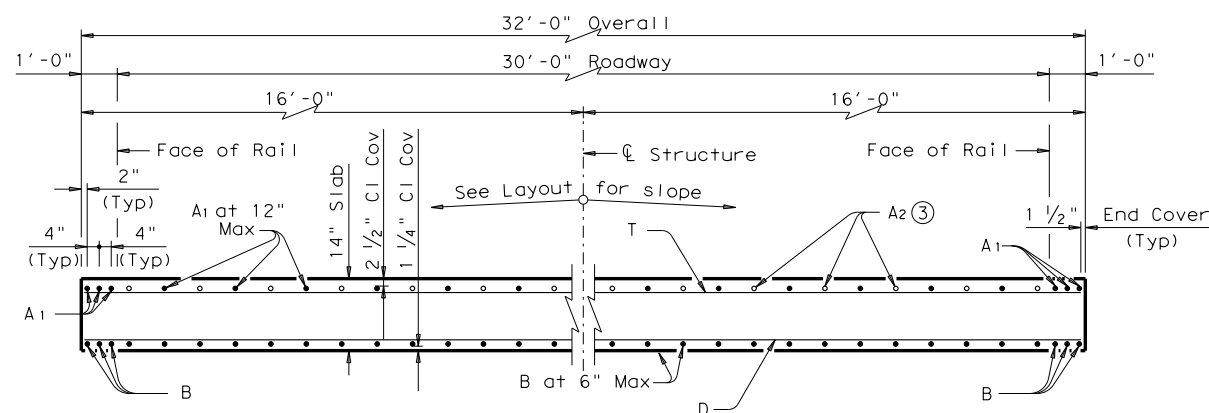

TYPICAL TRANSVERSE SECTION

- ③ Place Bars A2 between Bars A1 over Bent (See PLAN for Placement)

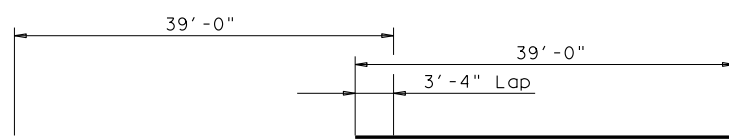

BARS A1

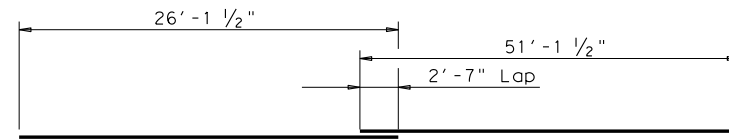

BARS B

- ④ Alternate Splices over Supports

TABLE OF ESTIMATED QUANTITIES CS-75-30 (15°)

Bar	No.	Size	Length	Weight
A1 ⑤	36	# 8	78'- 0"	7,497
A2	62	# 8	12'- 0"	1,986
B ⑥	66	# 8	77'- 3"	13,613
D	150	# 4	32'-11"	3,298
T	76	# 4	32'-11"	1,671
Reinforcing Steel				Lb 28,065
Class "S" Concrete ⑧				CY 104.0

- ⑤ Length shown includes one 3'-4" lap splice.
- ⑥ Length shown includes one 2'-7" lap splice.
- ⑦ See standard CS-MD for Expansion Joint Details.
- ⑧ Provide Class S(HPC) if shown elsewhere in the plans.

GENERAL NOTES:

Designed according to AASHTO LRFD Specifications.
 Details shown are for right forward skew. See Layout for actual skew direction. See standard CS-MD for additional slab span details.
 All reinforcing shall be Grade 60. Concrete strength f'c = 4,000 psi. When epoxy coated reinforcing is used, the lap splice lengths shown shall be increased by a factor of 1.5. This standard does not support the use of Transition Bents.

HL93 LOADING

		Bridge Division Standard	
75' C-I-P CONTINUOUS SLAB UNIT (25'-25'-25') 30 FT ROADWAY 15° SKEW CS-75-30-15			
FILE: scs28ste.dgn	DN: TxDOT	CK: TxDOT	DW: TxDOT
©TxDOT March 2009	CONT	SECT	JOB
REVISIONS			HIGHWAY
	DIST	COUNTY	SHEET NO.

DATE: FILE: