

DISCLAIMER: The use of this standard is governed by the "Texas Engineering Practice Act". No warranty of any kind is made by TxDOT for any purpose whatsoever. TxDOT assumes no responsibility for the conversion of this standard to other formats or for incorrect results or damages resulting from its use.

DATE: FILE:

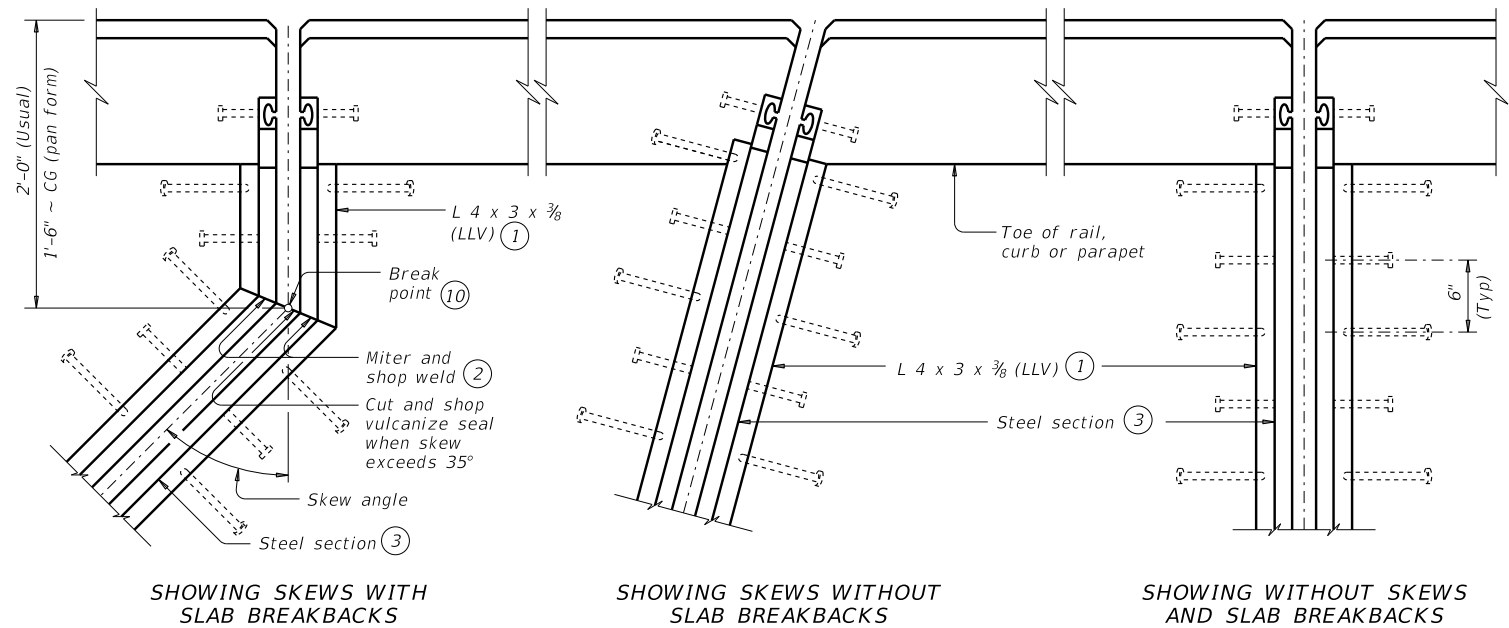

SHOWING SKEWS WITH SLAB BREAKBACKS

SHOWING SKEWS WITHOUT SLAB BREAKBACKS

SHOWING WITHOUT SKEWS AND SLAB BREAKBACKS

REDUCED LONGITUDINAL MOVEMENT RANGE

SKEW (deg)	JOINT SIZE	
	4"	5"
0	4.0"	5.0"
15	4.0"	5.0"
30	3.5"	4.3"
45	2.8"	3.5"

DESIGN NOTES:
 Joints installed on a skew have reduced ability to accommodate longitudinal movement. Use table values to determine the correct joint size for skewed installations.
 For other skews over 25 degrees, calculate reduced movement range by multiplying joint size by cosine (skew).

TABLE OF SEALED EXPANSION JOINT INFORMATION

MANUFACTURER	STEEL SECTION ③	STRIP SEAL			
		4" JOINT		5" JOINT	
		Seal Type	Joint Opening ④	Seal Type	Joint Opening ④
D.S. Brown	Type SSA2	A2R-400	1 3/4"	A2R-XTRA	2"
Watson Bowman Acme	Type A	SE-400	1 3/4"	SE-500	2"

- Use ASTM A36 steel for angles.
- Remove all burrs which will be in contact with seal prior to making splice.
- Shape of steel section shown is typical. Variations in sections must be approved by the Engineer.
- These openings are also the recommended minimum installation openings.
- Other conditions affecting the joint profile should be noted elsewhere.
- Reduce for sidewalk or parapet heights less than 6".
- 1/4" Max or as directed by the Engineer.
- Move transverse bars that are in conflict with SEJ studs, in either the bridge slab or approach slab, to rest at the junction of the studs.
- Ensure grout flows into holes to obtain proper concrete consolidation under angle.
- See Span details for location of break point.
- Align shipping angle perpendicular to joint.

PLANS OF END CONDITIONS

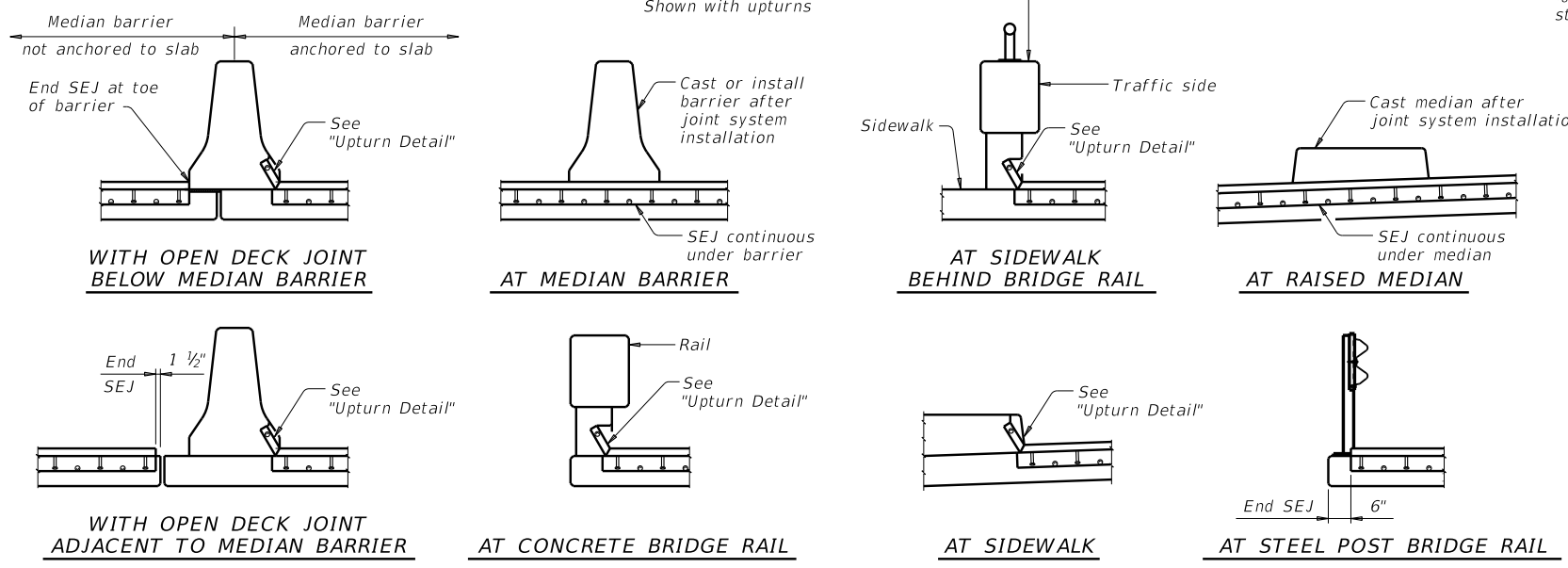

TYPICAL SECTIONS ⑤

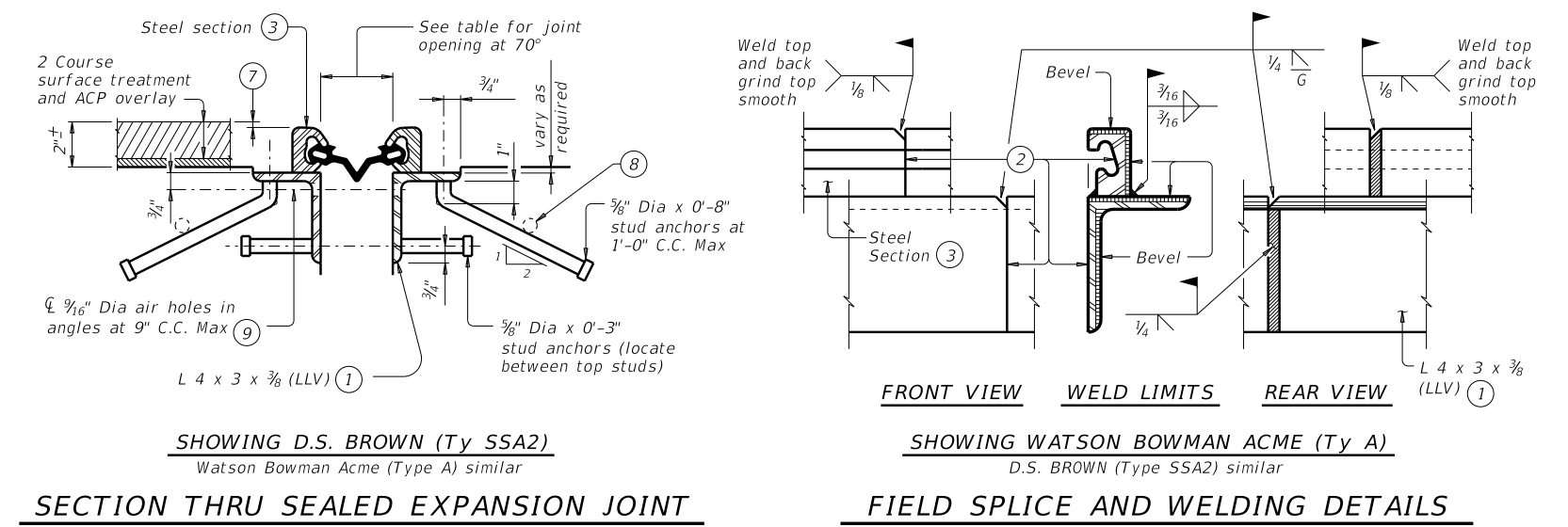

SHOWING D.S. BROWN (Ty SSA2)
 Watson Bowman Acme (Type A) similar

SHOWING WATSON BOWMAN ACME (Ty A)
 D.S. BROWN (Type SSA2) similar

SECTION THRU SEALED EXPANSION JOINT

FIELD SPLICE AND WELDING DETAILS

Weld preparation must be done by shop

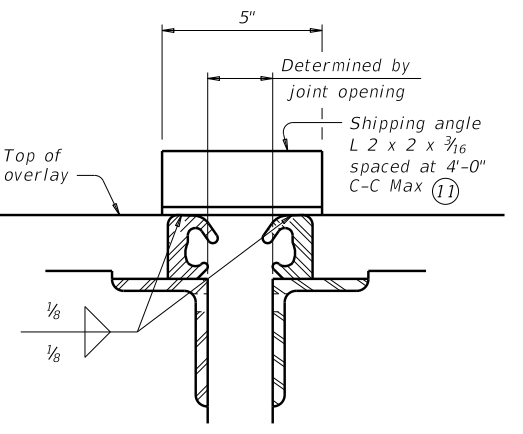
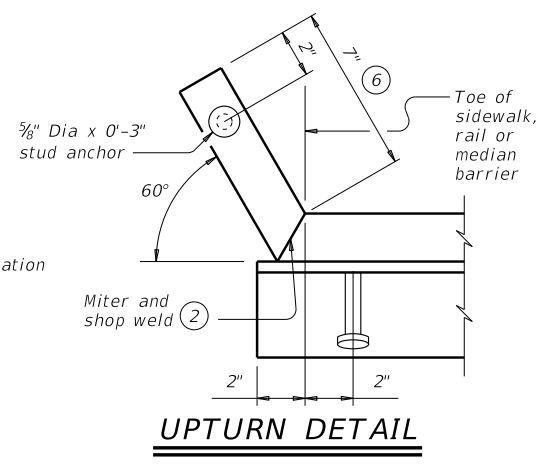

SHOWING D.S. BROWN (Ty SSA2)
 Watson Bowman Acme (Type A) similar
SHIPPING ANGLE

An alternate method of securing joint sections may be used if approved by the Bridge Division. Erection bolts are not allowed.

FABRICATION NOTES:
 Temporarily shop assemble corresponding sections of sealed expansion joints (SEJ), check for fit, and match mark for shipment. Secure corresponding sections together for shipment with shipping angle. Do not use erection bolts.
 The seal must be continuous and included in the price bid for sealed expansion joint.
 Ship steel sections in convenient lengths of 10'-0" Min and 24'-0" Max unless necessary for stage construction or widenings. One shop splice is permitted in each shipping length provided no piece is less than 2'-0" long and sufficient studs are added to limit the stud to shop splice distance to 2" Min and 4" Max.
 Weld studs in accordance with AWS D1.1.
 Butt weld all shop and field splices and grind smooth areas in contact with seal. Make all necessary field splice joint preparations in the shop.
 Paint the entire steel section with System II or IV primer in accordance with Item 446, "Field Cleaning and Painting Steel". Provide paints in accordance with Item 446.2. Prepare steel and apply paint in accordance with Item 446.4.7.3 and 446.4.7.4.
 Shop drawings for the fabrication of sealed expansion joints will not require the Engineer's approval if fabrication is in accordance with the details shown on this standard.

CONSTRUCTION NOTES:
 Secure the sealed expansion joint in position and place to the proper grade and alignment by welding braces to adjacent reinforcing steel, to prestressed beam stirrups, or to anchors cast in concrete diaphragms. Include cost of temporary bracing in the price bid for sealed expansion joint.
 Remove shipping angle immediately after each joint half is secured in place. Grind smooth, and touch up with organic zinc-rich paint.
 Clean and prepare seal cavity for seal installation as per the manufacturer's installation procedures.

GENERAL NOTES:
 Provide sealed expansion joints in the size and at locations shown on the plans.
 Minimum slab and overhang thickness required for the use of SEJ-S(O) is 6 1/2".

Texas Department of Transportation
 Bridge Division Standard

SEALED EXPANSION JOINT TYPE S WITH OVERLAY

SEJ-S(O)

FILE: sejsese1-19.dgn	DN: TxDOT	CK: TxDOT	DW: TxDOT	CK: TxDOT
©TxDOT April 2019	CONT	SECT	JOB	HIGHWAY
REVISIONS				
	DIST	COUNTY		SHEET NO.