

DISCLAIMER: The use of this standard is governed by the "Texas Engineering Practice Act". No warranty of any kind is made by TxDOT for any purpose whatsoever. TxDOT assumes no responsibility for the conversion of this standard to other formats or for incorrect results or damages resulting from its use.

DATE: FILE:

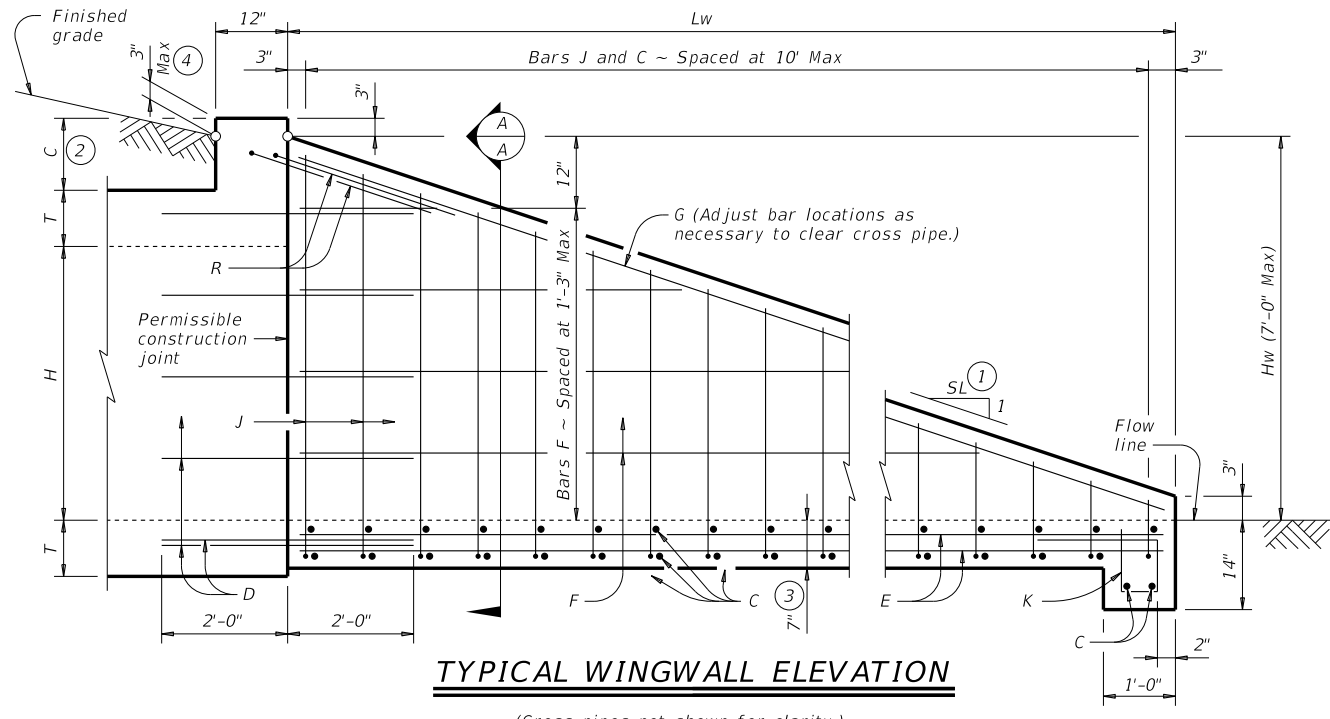

TYPICAL WINGWALL ELEVATION

(Cross pipes not shown for clarity.)

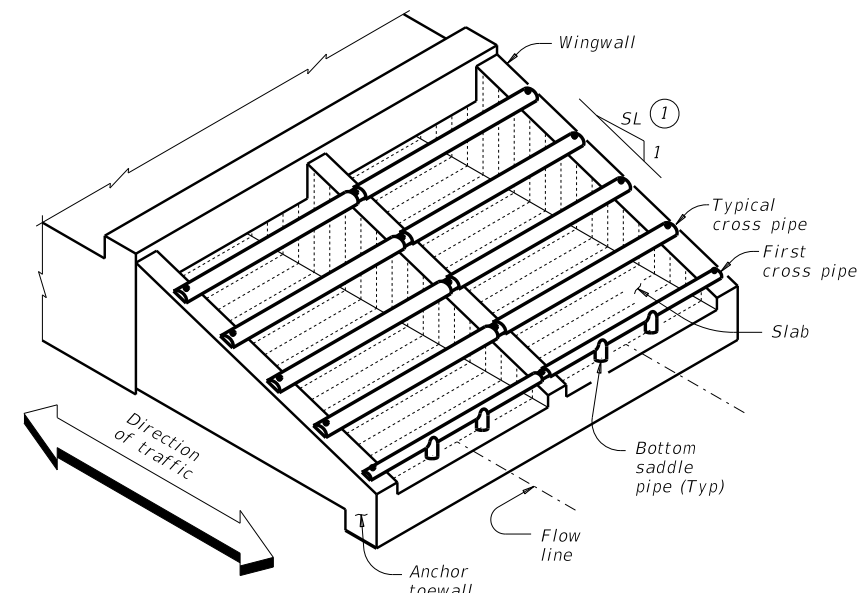

ISOMETRIC VIEW OF TYPICAL INSTALLATION

(Showing bolted anchor option.)

WING DIMENSION CALCULATIONS:

$$Hw = H + T + C - 0.250'$$

$$Lw = (Hw - 0.250') (SL)$$

For cast-in-place culverts:
 $Atw = (N) (S) + (N + 1) (U)$

For precast culverts:
 $Atw = (N) (2U + S) + (N - 1) (0.500')$

$$\text{Total Wingwall Area (SF)} = (0.5) (Hw + 0.250') (Lw) (N - 1)$$

$$\text{Total Concrete Volume (CY)} = [(Wingwall Area) (0.583') + (Lw) (Atw) (0.583') + (Atw) (1.000') (1.167' - 0.583')] \div (27)$$

$$\text{Total Reinforcing (Lb)} = (1.55) (Lw) (Atw) + (4.43) (Atw) + (K) (Hw) (N + 1) (\sqrt{Lw})$$

C = Height of curb above top of top slab (feet)
Hw = Height of wingwall (feet)
K = Constant value for use in formulas
Slope SL:1 K
6:1 ~ 10:41
Atw = Anchor toewall length (feet)
Lw = Length of wingwall (feet)
N = Number of culvert barrels
SL:1 = Side slope ratio (horizontal : 1 vertical)
See applicable box culvert standard for H, S, T, and U values.

MATERIAL NOTES:
Provide Grade 60 reinforcing steel.
Provide galvanized reinforcing steel if required elsewhere in the plans. Adjust reinforcing as necessary to provide a minimum clear cover of 1 1/2".
Provide Class "C" concrete (f'c = 3,600 psi).
Provide pipe runners, cross pipes, and anchor pipes meeting the requirements of ASTM A53 (Type E or S, Gr B), ASTM A500 Gr B, or API 5LX52.
Provide ASTM A307 bolts.
Galvanize all steel components, except the concrete reinforcing, unless required elsewhere in the plans, after fabrication.
Repair galvanizing damaged during transport or construction in accordance with Item 445, "Galvanizing."

GENERAL NOTES:
Designed according to AASHTO LRFD Bridge Design Specifications.
The safety end treatments shown herein are intended for use in those installations where out of control vehicles are likely to traverse the openings approximately perpendicular to the cross pipes.
Cross pipes are designed for a traversing load of 10,000 pounds at yield as recommended by Research Report 280-2F, "Safety Treatment of Roadside Parallel-Drainage Structures", Texas Transportation Institute, March 1981.
The quantities for concrete, reinforcing steel, and cross pipes resulting from the formulas given herein are for Contractor's information only.
See the Box Culvert Supplement (BCS) standard sheet for additional dimensions and information.
Alternate design drawings bearing the seal of a professional engineer will be acceptable for precast construction of the safety end treatments.

Cover dimensions are clear dimensions, unless noted otherwise. Reinforcing dimensions are out-to-out of bars.

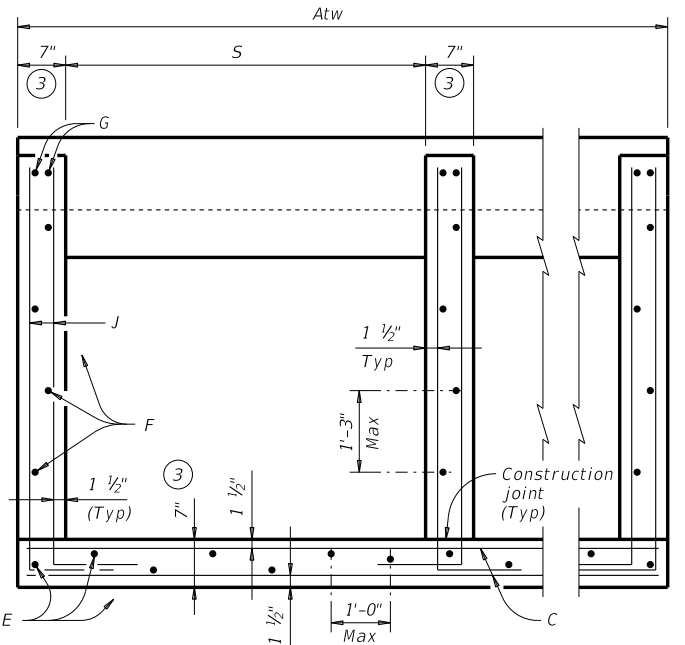

SECTION A-A

(Showing typical wingwall and wing slab reinforcing. Pipe runners not shown for clarity.)

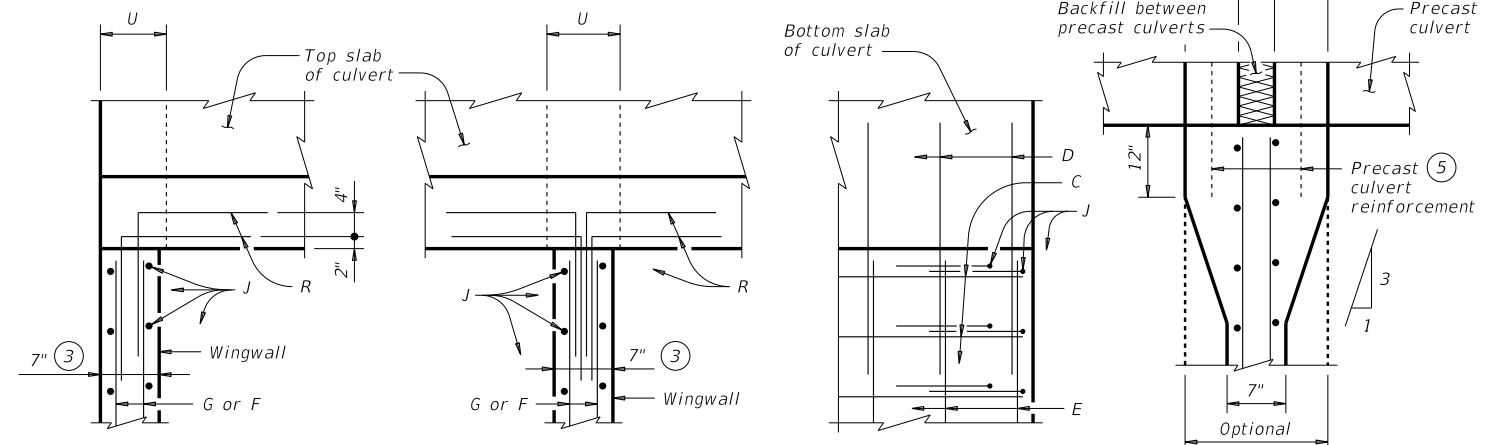

PLAN VIEWS OF CORNER DETAILS

TABLE OF REINFORCING BAR SIZES AND SPACING

Bar	Size	Spacing
C	#4	10" Max
D	#4	Match F and E
E	#4	1'- 0" Max
F	#4	1'- 3" Max
G	#6	As shown
J	#4	10" Max
K	#4	1'- 0" Max
R	#4	As shown

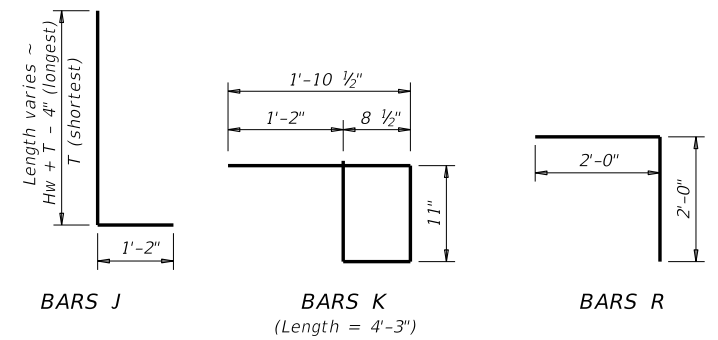

- Provide 6:1 or flatter slope.
- 0" Min to 5'-0" Max. Estimated curb heights are shown elsewhere in the plans. For structures without railing and curbs taller than 1'-0", refer to Extended Curb Details the Extended Curb Details (ECD) standard sheet.
- Wingwall and slab thicknesses may be the same as the adjacent culvert wall and slab thicknesses (7" Minimum). If thicknesses greater than the minimum (7") are used, no changes will be made in quantities and no additional compensation will be allowed.
- For vehicle safety, reduce height, if necessary, to provide a maximum 3" projection above finished grade. No changes will be made in quantities and no additional compensation will be allowed for this work.
- For culverts with C = 0", the precast culvert reinforcing may extend 1'-0" minimum into wingwall. Wingwall bars D and R may be omitted. Otherwise, refer to the Wingwall Connection detail on the Box Culvert Precast Miscellaneous Details (SCP-MD) standard sheet.

Texas Department of Transportation
SAFETY END TREATMENT FOR BOX CULVERTS (MAXIMUM Hw = 7'-0") TYPE I ~ PARALLEL DRAINAGE
SETB-PD

FILE: setbpdse-22.dgn	DN: GAF	CK: CAT	DW: TxDOT	CK: TxDOT
©TxDOT February 2020	CONT	SECT	JOB	HIGHWAY
REVISIONS				
06-2022 - Wing dimensions	DIST	COUNTY	SHEET NO.	

Bridge Division Standard

DISCLAIMER: The use of this standard is governed by the "Texas Engineering Practice Act". No warranty of any kind is made by TxDOT for any purpose whatsoever. TxDOT assumes no responsibility for the conversion of this standard to other formats or for incorrect results or damages resulting from its use.

DATE:
FILE:

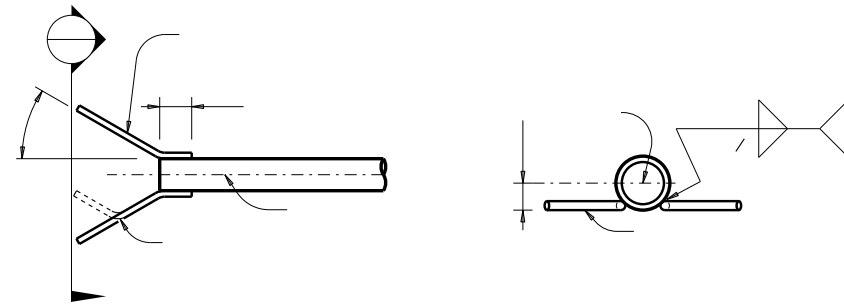
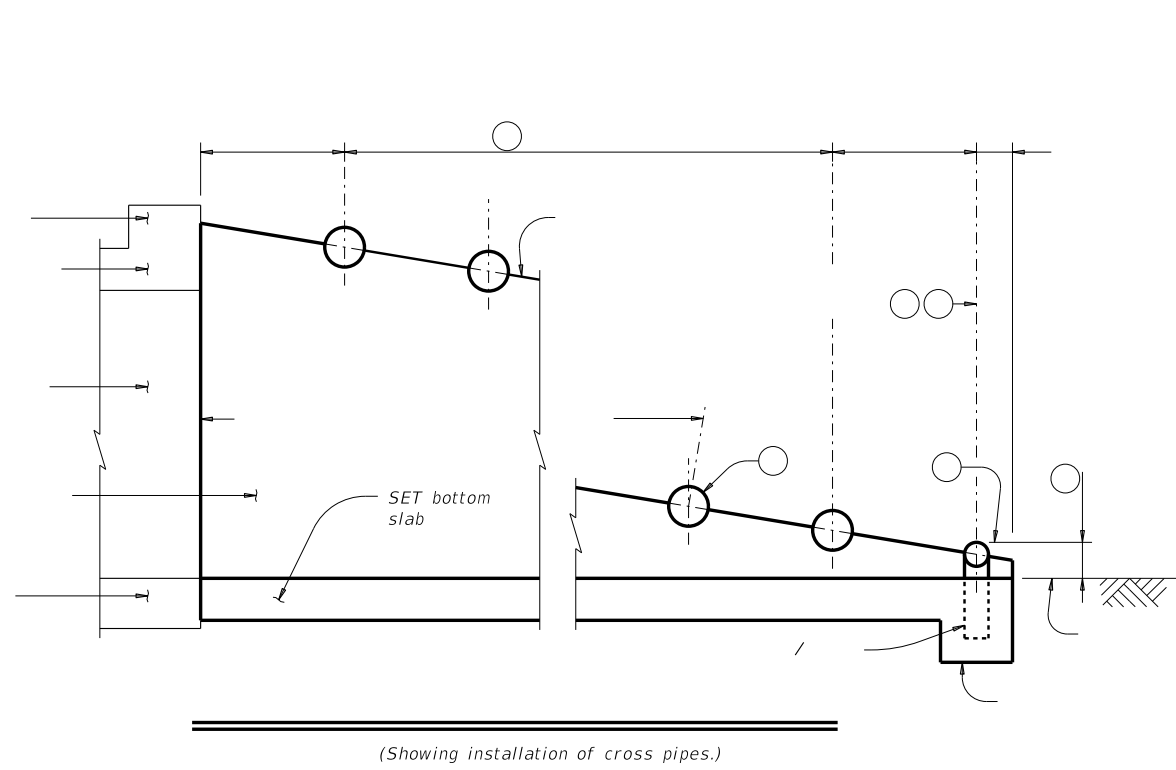

- ⑥
-
-
-
-
-

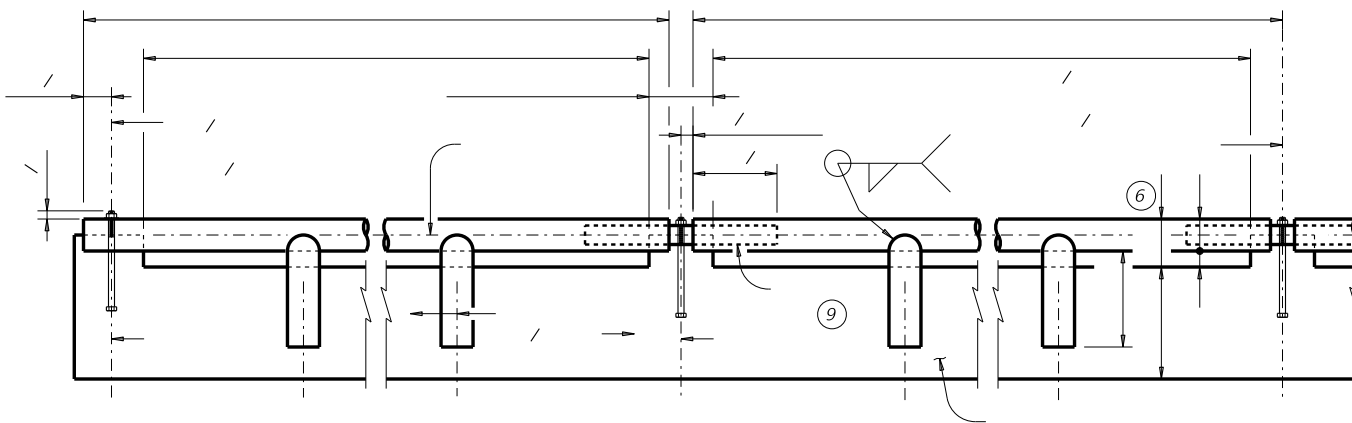
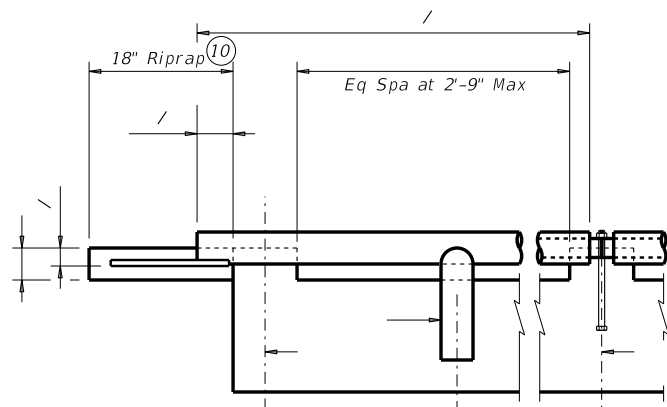
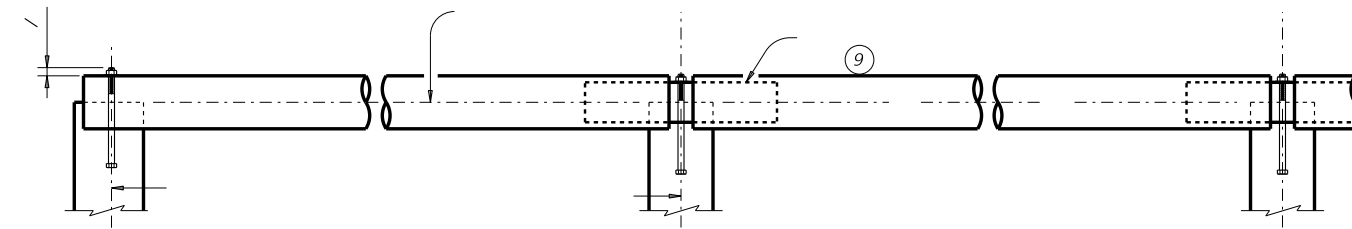
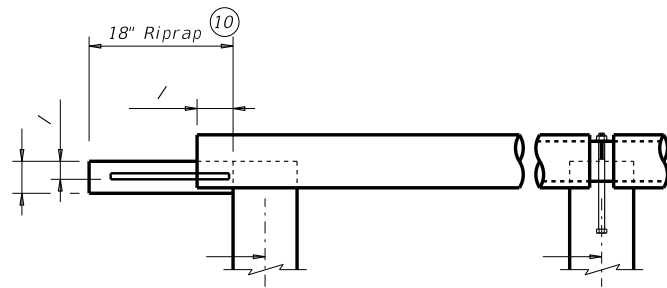

	/	/	

/		
3" STD	3.500"	
/		3.548"
	6.	

SHEET 2 OF 2



SAFETY END TREATMENT
FOR BOX CULVERTS
(MAXIMUM Hw = 7'-0")
TYPE I ~ PARALLEL DRAINAGE

SETB-PD

FILE:	DN: GAF	CK: CAT	DW: TxDOT	CK:
©TxDOT February 2020	CONT	SECT	JOB	HIGHWAY
REVISIONS				
	DIST	COUNTY	SHEET NO.	