

DISCLAIMER: THE USE OF THIS STANDARD IS COVERED BY THE "TEXAS ENGINEERING PRACTICE ACT". NO WARRANTY OF ANY KIND IS MADE BY TxDOT FOR ANY PURPOSE WHATSOEVER. TxDOT ASSUMES NO RESPONSIBILITY FOR THE CONVERSION OF THIS STANDARD TO OTHER FORMATS OR FOR INCORRECT RESULTS OR DAMAGES RESULTING FROM ITS USE.

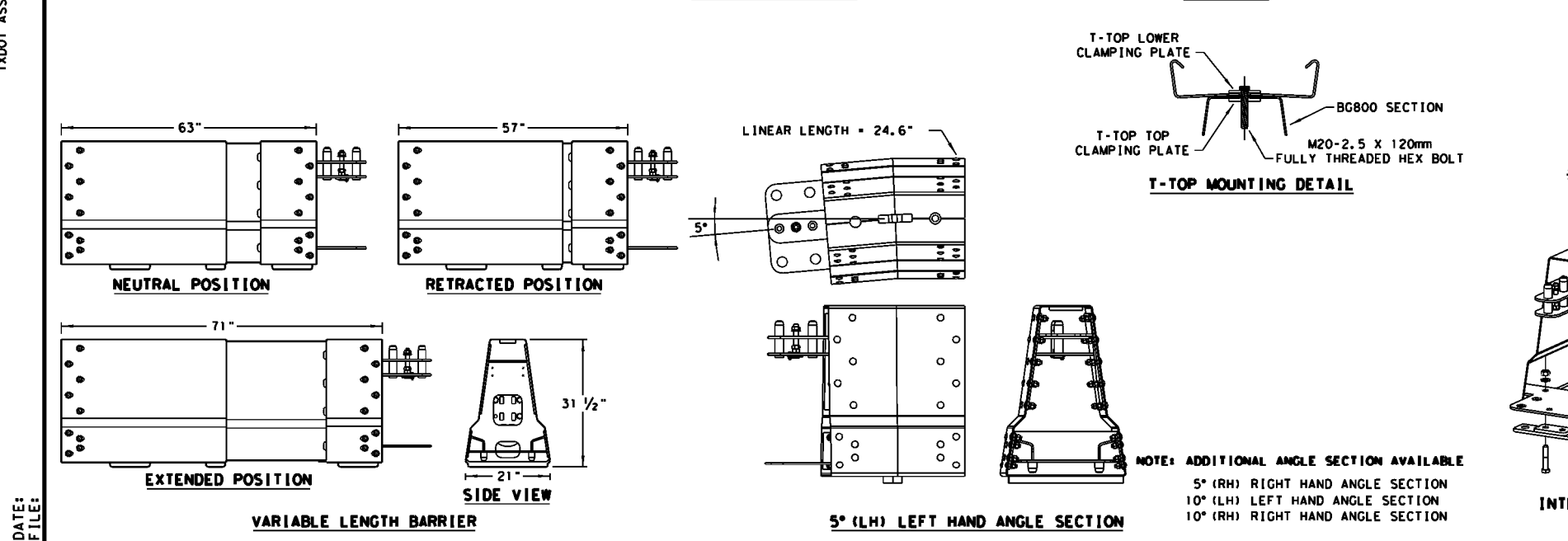
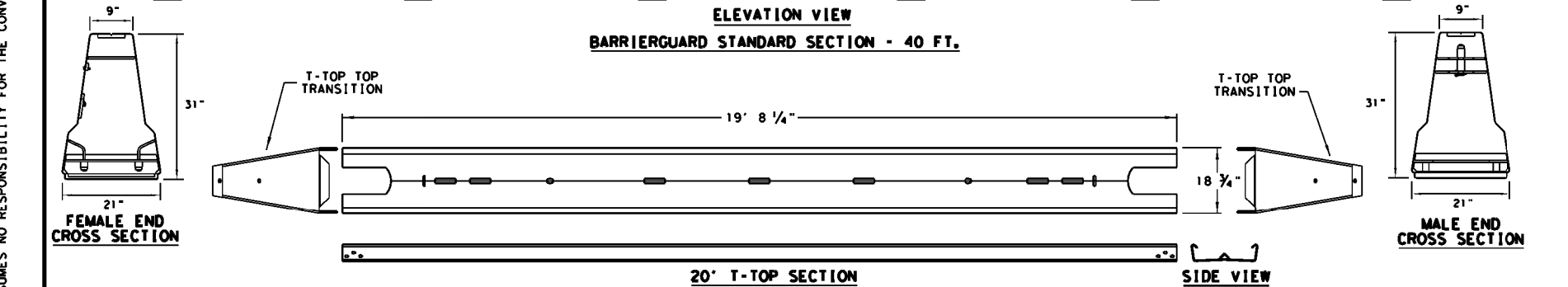
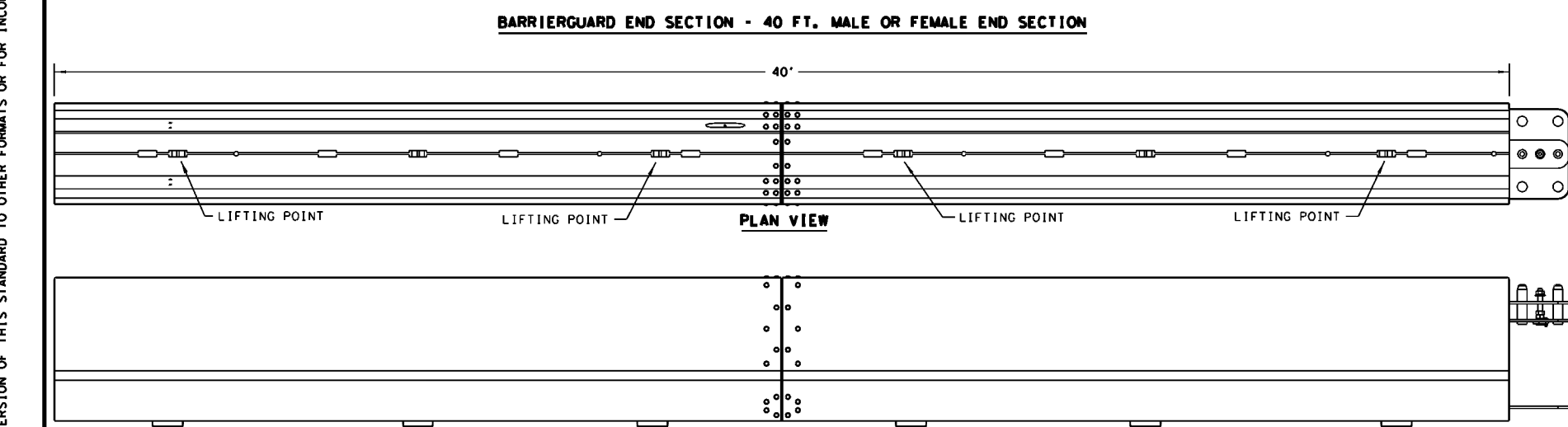
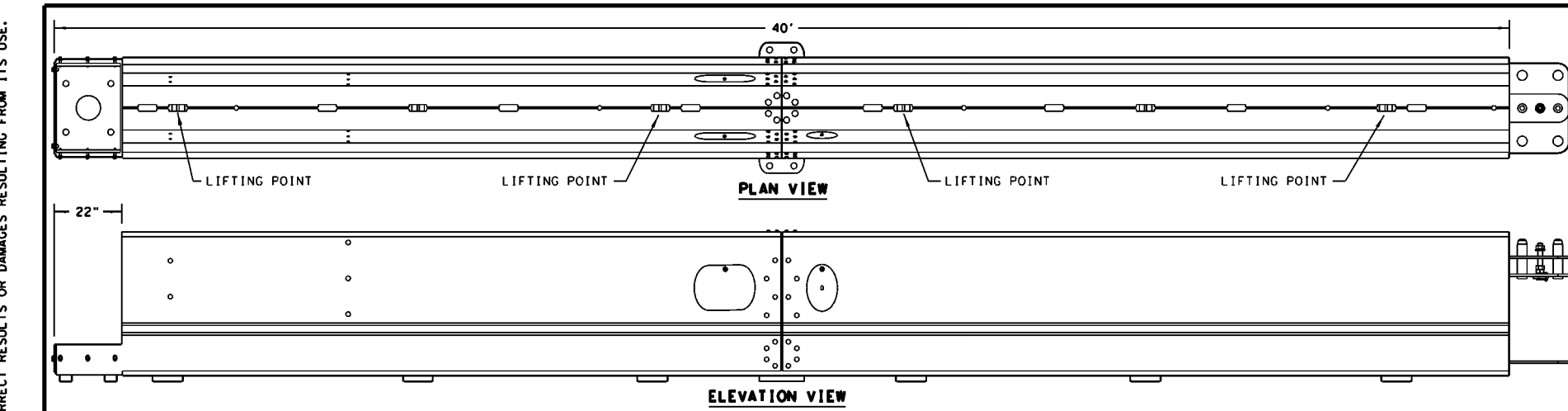

DATE: FILE:

**GENERAL NOTES**

1. THE SYSTEM SHOWN ON THIS DRAWING IS A PROPRIETARY BARRIER TRADED AS BARRIERGUARD 800 AND BARRIERGUARD 800 MDS AND HAS BEEN DESIGNED AND MANUFACTURED BY LAURA METAAL ROAD SAFETY INC. FOR TECHNICAL ASSISTANCE AND APPLICATION SUPPORT CONTACT LEE STUART AT LAURA METAAL ROAD SAFETY INC. AT (702) 664-2009 OR [lee.stuart@laura-metaal.com](mailto:lee.stuart@laura-metaal.com)
2. THE BARRIERGUARD 800 SYSTEM HAS BEEN CRASH TESTED TO MASH AND HAS FHWA APPROVAL AS A TL-3 BARRIER. THE DEFLECTION TABLE OUTLINES BASIC SYSTEM PERFORMANCE AND COMPONENT ANCHORING REQUIREMENTS.
3. THIS DRAWING PACKAGE PROVIDES THE RELEVANT INFORMATION AND GENERAL GRAPHICS REQUIRED TO IDENTIFY THE COMPONENT PARTS OF BARRIERGUARD 800 AND THEIR INCORPORATION AS A WHOLE SYSTEM FOR DEPARTMENTAL STANDARD APPLICATIONS.
4. BARRIERGUARD 800 REQUIRES ANCHORING (PINNING) AT EACH END OF THE INSTALLED LENGTH. (INTERMEDIATE ANCHORS CAN BE USED TO REDUCE DEFLECTION).
5. INSTALLATION OF BARRIERGUARD 800 OR BARRIERGUARD 800 MDS, NORMALLY STARTS WITH A MALE TERMINAL SECTION AND IS FINISHED WITH A FEMALE TERMINAL SECTION. STANDARD SECTIONS ARE USED BETWEEN THE TERMINAL SECTIONS TO OBTAIN THE REQUIRED LENGTH OF POSITIVE BARRIER PROTECTION.
6. THE FULL HEIGHT TERMINAL (FHT) SECTIONS MAY BE CAPPED WITH A FHT COVER, HOWEVER IF EXPOSED TO ON-COMING TRAFFIC THE END SHOULD BE PROTECTED WITH A SUITABLE CRASH CUSHION. THE BARRIERGUARD 800 RANGE IS COMPATIBLE WITH MOST COMMONLY USED CRASH CUSHION END TREATMENTS. FOR DETAILS OF BARRIERGUARD 800 CRASH CUSHION CONNECTIONS THAT ARE NOT DETAILED WITHIN THESE DRAWINGS, PLEASE CONTACT LAURA METAAL ROAD SAFETY INC. FOR MORE DETAILS. THE FULL HEIGHT TERMINAL COVER IS SUITABLE FOR THE "DOWN STREAM" END OF A SYSTEM THAT DOES NOT HAVE EXPOSURE TO ON-COMING TRAFFIC.
7. WHEN INSTALLING THE MINIMUM DEFLECTION SYSTEM (MDS), THE SYSTEM CAN BE INSTALLED WITH ADDITIONAL INTERMEDIATE ANCHORS ALONG THE LENGTH OF THE BARRIER RUN AT INTERVALS SHOWN IN THE DEFLECTION TABLE. EACH BARRIER RUN CAN BE MADE UP OF ANY MIXTURE OF THE SYSTEMS BY THE INTRODUCTION OF INTERMEDIATE ANCHORS AND/OR T-TOP AS REQUIRED.
8. THERE ARE SEVERAL METHODS OF ACHIEVING RADIUS IN A LENGTH OF BARRIERGUARD 800. RADIUS CAN BE ACHIEVED USING VARIOUS METHODS AND THUS ALLOWING THE BARRIERGUARD TO FOLLOW THE DESIRED CURVATURE IN THE INSTALLATION, THESE METHODS ARE, THE MOVEMENT IN THE QUICKLINK, ADJUSTABLE 20FT. SECTIONS OR SHORT ANGLED SECTIONS WHICH ALLOW A RADIUS AS LOW AS 12FT. FOR FURTHER INFORMATION AND ADVICE CONTACT LAURA METAAL ROAD SAFETY INC.
9. A BARRIERGUARD 800 VARIABLE LENGTH BARRIER (VLB) SECTION SHOULD BE USED WHEN BARRIERGUARD 800 OR BARRIERGUARD 800 MDS IS ANCHORED ACROSS A BRIDGE EXPANSION JOINT. IF T-TOP IS TO BE USED IN CONJUNCTION WITH THE VLB, THE T-TOP SHOULD BE USED FOR MINIMUM 40FT ON EITHER SIDE OF THE VLB AND TERMINATED WITH TRANSITIONS. THE VLB SECTION PROVIDES APPROXIMATELY 7in OF EXTENSION AND 7in OF CONTRACTION. MULTIPLE VLB'S CAN BE LINKED TOGETHER TO PROVIDE MORE EXPANSION OR CONTRACTION. THE VLB'S SHOULD BE PLACED IN THE VICINITY OF THE EXPANSION JOINT. THE VLB DOES NOT NEED TO BE PLACED DIRECTLY OVER THE EXPANSION JOINT BUT MUST BE BETWEEN THE NEAREST ANCHORS ON EACH SIDE OF THE JOINT. IT IS RECOMMENDED THAT THE VLB IS PLACED WITHIN 40FT OF THE JOINT.
10. THE T-TOP CAN BE INSTALLED EITHER BEFORE OR AFTER THE BARRIERGUARD 800 HAS BEEN FULLY ASSEMBLED AND ANCHORED IN PLACE. T-TOP IS REQUIRED WHEN THE BARRIERGUARD 800 IS USED AS A MDS, ANCHORED EVERY 20FT, GATE SECTIONS AND VARIABLE LENGTH BARRIERS. THE T-TOP SHOULD EXTEND 40FT ON EITHER SIDE OF THESE CONDITIONS AND BE TERMINATED WITH TRANSITIONS.
11. THE BARRIERGUARD 800 RANGE HAS BEEN DESIGNED TO BE USED ON AND HAS BEEN TESTED ANCHORED ON ASPHALT, CONCRETE AND COMPACTED SUBBASE. CONTACT LAURA METAAL ROAD SAFETY INC. FOR FURTHER INFORMATION.
12. BARRIERGUARD 800 COMPONENTS ARE MANUFACTURED IN SI (METRIC) UNITS. ENGLISH UNITS SHOWN ARE APPROXIMATE. ALL COMPONENTS ARE FULLY GALVANIZED.
13. BARRIERGUARD 800 SYSTEMS SHALL BE ASSEMBLED AND INSTALLED IN ACCORDANCE WITH THE MANUFACTURERS DETAILED DRAWINGS, PROCEDURES AND SPECIFICATIONS. FOR ANY INSTALLATIONS OUTSIDE OF THE SCOPE OF THESE DRAWINGS PLEASE CONTACT LAURA METAAL ROAD SAFETY INC. FOR DETAILS.

	STANDARD SYSTEM	MINIMUM DEFLECTION SYSTEMS (MDS)
DESCRIPTION	ONLY ANCHORED AT THE EXTREME ENDS OF THE BARRIER LENGTH	ANCHORED EVERY 20 FT.
DEFLECTION AT MASH TL-3	5'-6"	18 1/2"
T-TOP REQUIREMENTS	NONE REQUIRED	REQUIRED FOR MDS SECTIONS

	RESIN STUD ANCHORS		DRIVEN ANCHORS		Hilti HSL-3 SHALLOW MECHANICAL	
	CONCRETE *	UNREINFORCED CONCRETE *	ASPHALT	ASPHALT SUBBASE/SOIL	CONCRETE	
ANCHOR DIAMETER	1 in.	1 in.	1 in.	1-3/16 in.	5-1/2 in.	**
EMBEDMENT DEPTH	6 in.	8 in.	16 in.	16 in.	32 in.	**
DRILL DIAMETER	1-1/8 in.	1-1/8 in.	1-1/8 in.	1-3/16 in.	DRIVEN	**
PULL OUT CAPACITY (MIN)	17500 lb	17500 lb	N/A	N/A	N/A	**
SHEAR CAPACITY (MIN)	25000 lb	25000 lb	N/A	N/A	N/A	**

\* ALTERNATIVE ANCHORS INCLUDING MECHANICAL ANCHORS FOR CONCRETE MAYBE USED IF THEY MEET THE STRENGTH REQUIREMENTS LISTED, DETAILS WILL BE MANUFACTURER SPECIFIC.  
 \*\* CONTACT: LAURA METAAL ROAD SAFETY INC. FOR SPECIFIC APPLICATION.

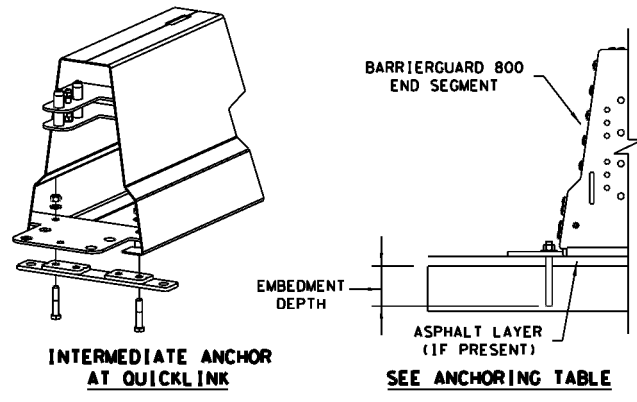

Design Division Standard

**BARRIERGUARD 800 SYSTEM**  
**STEEL BARRIER**  
**MASH TL-3**  
**BARRIERGUARD-19**

FILE: barrierguard19.dgn	DN: TxDOT	CK: KM	DW: VP	CK:
© TxDOT: JULY 2019	CONT	SECT	JOB	HIGHWAY
REVISIONS	DIST	COUNTY	SHEET NO.	