

DISCLAIMER: The use of this standard is governed by the "Texas Engineering Practice Act". No warranty of any kind is made by TxDOT for any purpose whatsoever. TxDOT assumes no responsibility for the conversion of this standard to other formats or for incorrect results or damages resulting from its use.

**Preferred Installation:** Locate post #2 away from nearest traffic. System has been successfully tested with opposite installation.

**Length-of-Need Cass Cable Terminal (CCT):**  
**Departure Installation:** Length-of-Need: 44'-9" (At Post #8)  
**Approach Installation:** Length-of-Need: 19'-9" (12" Past Post #4)

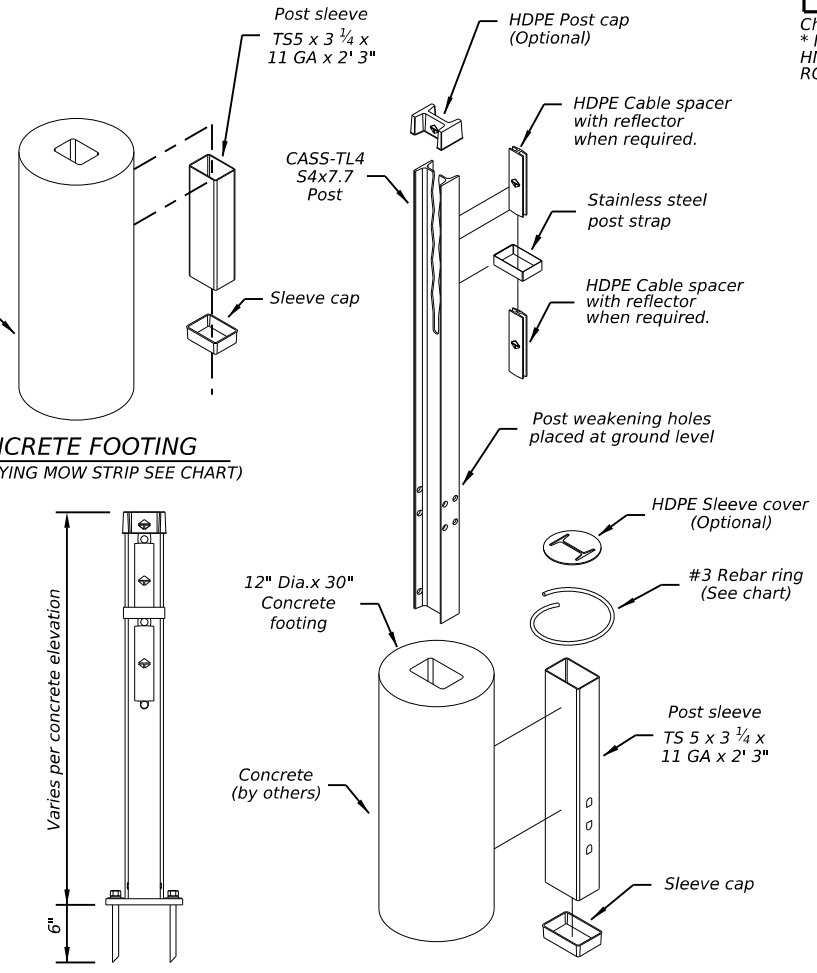
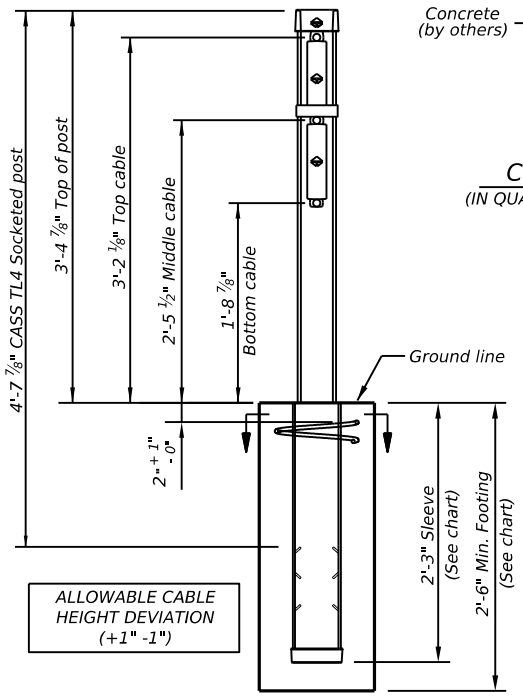
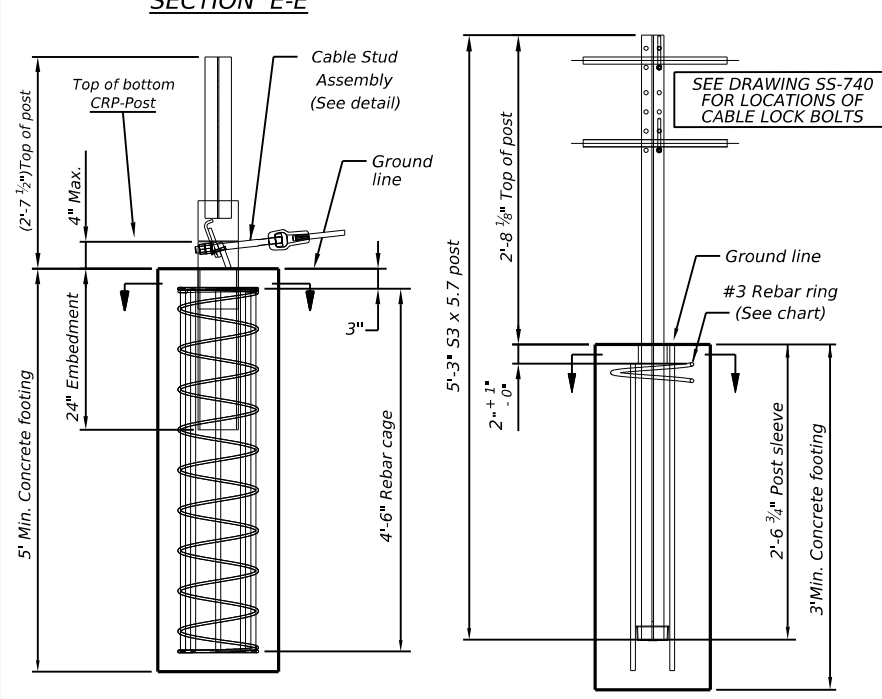
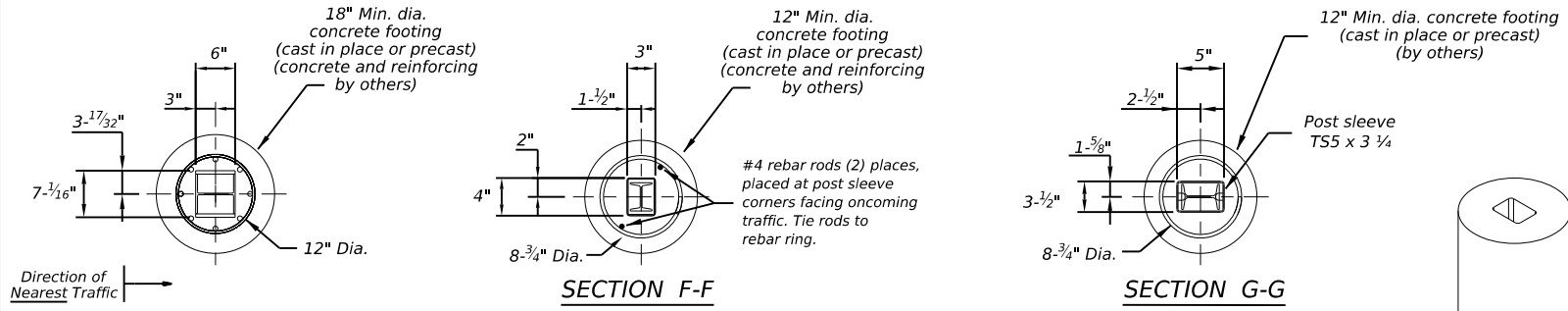
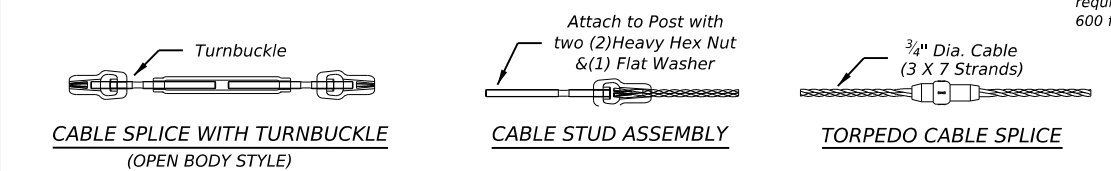
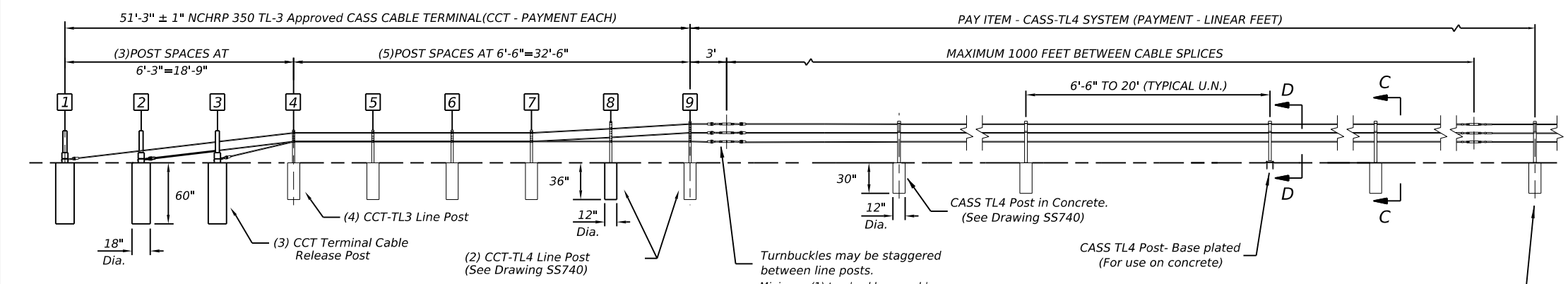
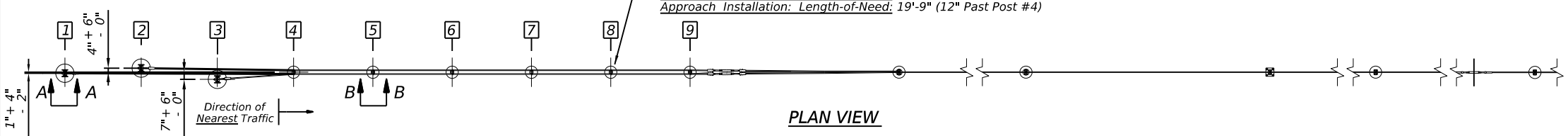

**GENERAL NOTES**

1. This drawing is a general overview of CASS TL-4 Barrier System. See SS-740 (latest version) for specific details of CASS cable terminal (CCT) and cable safety system (CASS) requirements, proper installation, options and specification.
2. CASS is designed for bi-directional traffic flows and can be installed on either side of the median. Contact Trinity (800-527-6050) or consult the design, installation, or repair manual(s) for additional information.
3. All concrete for CASS footings shall be TxDOT class A. If class A or stronger concrete is utilized for the mowstrip, please see chart below for allowable footing depth and sleeve deviations.
4. All posts shall be socketed unless otherwise specified. All cables shall be pre-stretched unless otherwise specified.
5. For payment see Special Specification "Cable Barrier System".
6. CASS-TL4 shall be installed on shoulders or medians with slopes of 6:1 or flatter without obstructions, depressions, etc. That may significantly affect the stability of an errant vehicle. Grading of site and/or appropriate fill materials may be required. The designer/installer shall "Flatten" or "Round" various topographical inconsistencies that could interfere with the ability of the installer to consistently maintain the design height (in relation to the terrain) of the cables. Please consult manual(s) and / or TxDOT Memo(s) for installations in "Ditch Sections".
7. CASS TL-4 post spacing may be modified to avoid obstacles that conflict with the installation of cass-tl4 line posts or to reduce deflection on radiuses. No post space can exceed the maximum post TxDOT space limit of 20'. Reducing or increasing post spacing affects deflection. CASS TL-4 may be laterally transferred at a rate not to exceed 30:1.
8. Post foundations may be drilled through existing pavement. Please see line post foundation chart for minimum footing requirements in various applications.
9. For aesthetic purposes Trinity recommends all sleeves, driven posts, and lower cable release posts to be installed reasonably plumb (approximately 1/8" per foot).
10. CASS TL-4 shall be installed in well-drained, compacted, NCHRP Report 350 Standard soil. If soil does not meet this classification, if solid rock/concrete is encountered below grade or if soil is susceptible to severe freeze/thaw cycles, please contact Trinity about alternate footing design(s). Trinity suggests the use of "Mow strips" for erosion prevention and ease of maintenance / installation.
11. See the Texas MUTCD for proper "Barrier" Delineation.

MOW STRIP DETAIL*			CONCRETE FOOTING CHART		
MOW STRIP	DEPTH	WIDTH	FOOTING	TUBE SLEEVE	REBAR RING
NONE			30" Min.	27" Min.	YES
HMA	6" Min.	3' Min.	27" Min.	15" Min.	NO
HMA	8" Min.	3' Min.	24" Min.	15" Min.	NO
RC	3" Min.	3' Min.	24" Min.	15" Min.	NO

Chart does not apply to Terminal Posts 1 thru 9.  
 \* Mow strip or pavement.  
 HMA = Hot Mix Asphalt (Not Recycled Asphalt Pavement).  
 RC = Reinforced Concrete (TxDOT Class A Minimum).

CABLE TENSION CHART	
FAHRENHEIT DEGREES	PRE-STRETCHED LB / FORCE
-10	7300
0	7000
10	6600
20	6300
30	6000
40	5600
50	5300
60	5000
70	4600
80	4300
90	4000
100	3600
110	3300
120	3000
130	2700
140	2500
150	2300

Trinity Highway Products, LLC.  
 2525 Stemmons Freeway  
 Dallas, TX 75207  
 Phone: (800) 644-7976

Product.INFO@TRIN.NET

Allowable deviation from chart in tangent sections: +800, -200 pounds/force. Cable tension readings are typically higher in curved cable sections.

**TRINITY CABLE SAFETY SYSTEM (TL-4) CASS (TL4) -14**

FILE: casst1414.dgn	DN: TxDOT	CK: RM	DW: VP	CK:
©TxDOT: March 2014	CONT	SECT	JOB	HIGHWAY
REVISIONS		DIST	COUNTY	SHEET NO.

Design Division Standard

DATE: FILE: