

DISCLAIMER: The use of this standard is governed by the "Texas Engineering Practice Act". No warranty of any kind is made by TxDOT for any purpose whatsoever. TxDOT assumes no responsibility for the conversion of this standard to other formats or for incorrect results or damages resulting from its use.

TABLE NO.1 LONGITUDINAL STEEL				
SLAB THICKNESS AND BAR SIZE		LONGITUDINAL STEEL BARS	FIRST SPACING AT EDGE OR JOINT	LONG. STEEL VERTICAL POSITION FROM BOTTOM OF PAVEMENT
T (IN.)	BAR SIZE	SPACING C (IN.)	SPACING a (IN.)	T1 (IN.)
7.0	#5	6.5	3 TO 4	3.5
7.5	#5	6.0	3 TO 4	3.75
8.0	#6	9.0	3 TO 4	4.0
8.5	#6	8.5	3 TO 4	4.25
9.0	#6	8.0	3 TO 4	4.5
9.5	#6	7.5	3 TO 4	4.75
10.0	#6	7.0	3 TO 4	5.0
10.5	#6	6.75	3 TO 4	5.5
11.0	#6	6.5	3 TO 4	6.0
11.5	#6	6.25	3 TO 4	6.5
12.0	#6	6.0	3 TO 4	7.0
12.5	#6	5.75	3 TO 4	7.5
13.0	#6	5.5	3 TO 4	8.0

TABLE NO.2 TRANSVERSE STEEL AND TIE BARS						
SLAB THICKNESS (IN.)	TRANSVERSE STEEL		TIE BARS AT LONGITUDINAL CONTRACTION JOINT (SECTION Z-Z)		TIE BARS AT LONGITUDINAL CONTRACTION JOINT (SECTION Y-Y)	
	BAR SIZE	SPACING (IN.)	BAR SIZE	SPACING (IN.)	BAR SIZE	SPACING (IN.)
7.0 - 7.5	#5*	48	#5*	48	#5*	24
8.0 - 13.0	#5*	48	#6	48	#6	24

*CONTRACTOR MAY USE #6 REINFORCING STEEL INSTEAD OF #5 REINFORCING STEEL OR COMBINATION OF EACH SIZE

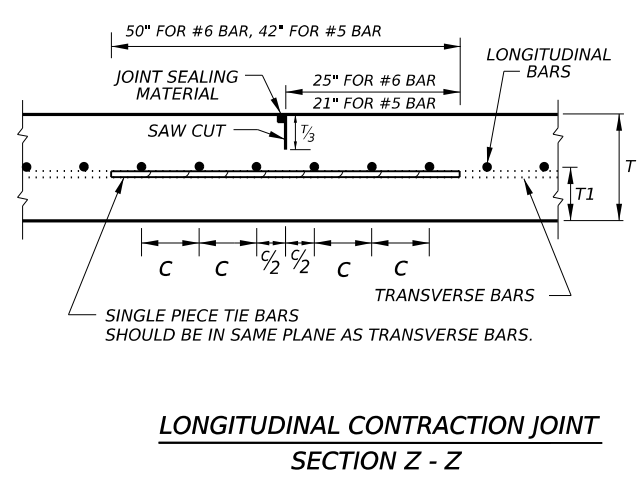
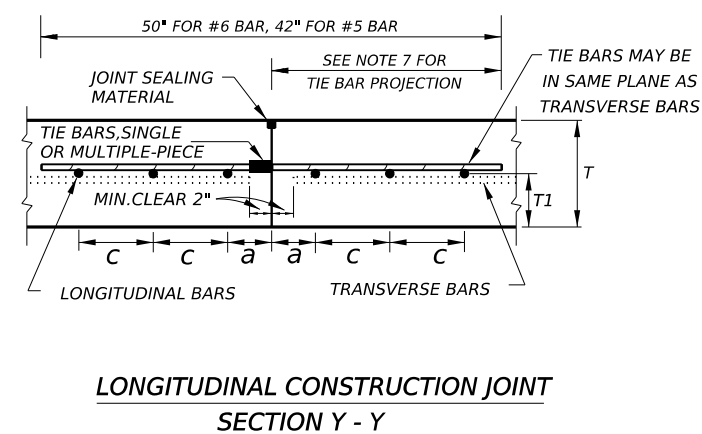
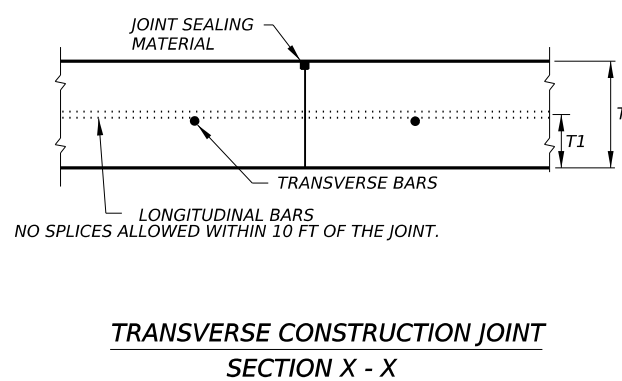
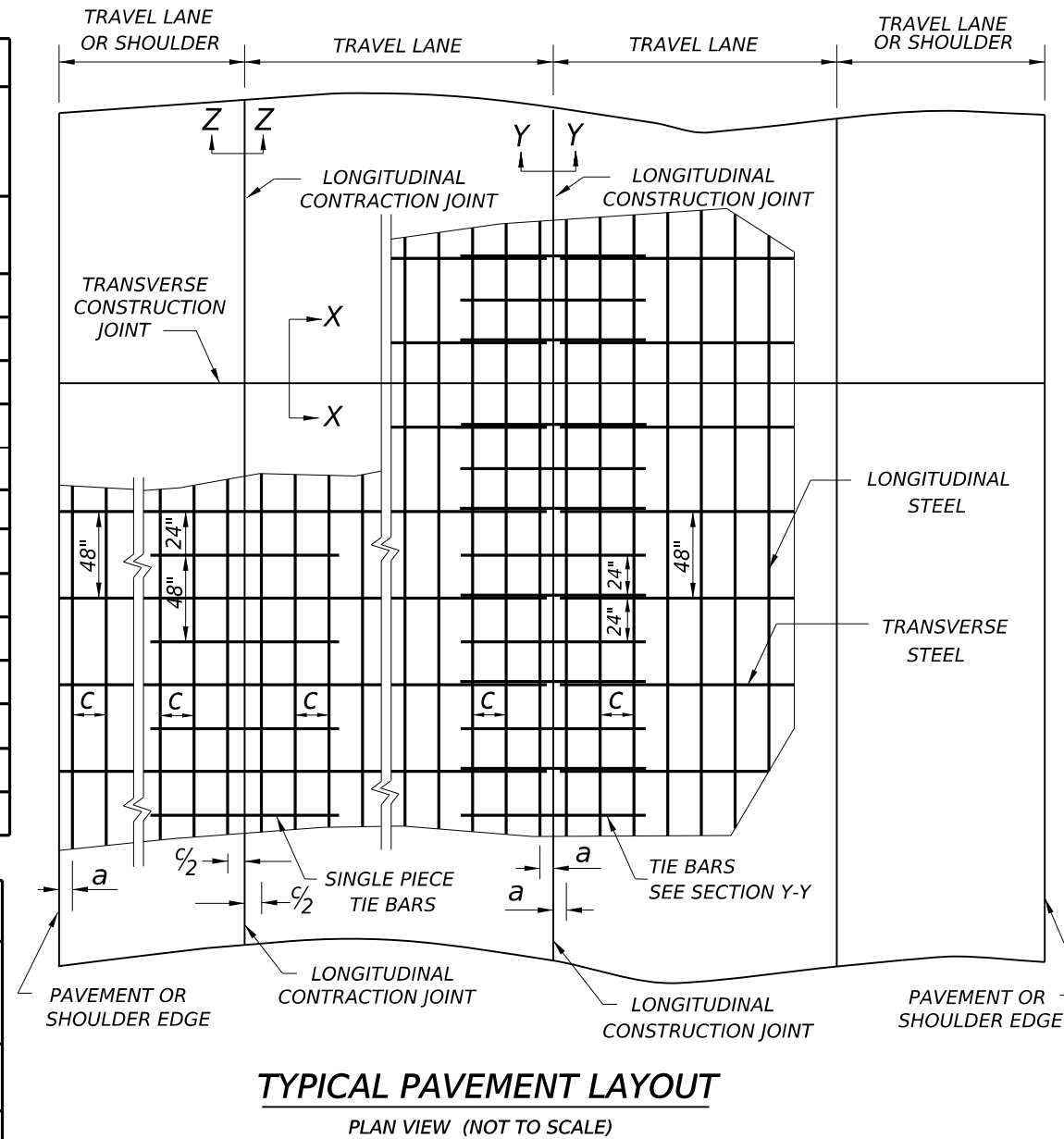

GENERAL NOTES

1. DETAILS FOR PAVEMENT WIDTH, PAVEMENT THICKNESS AND THE CROWN CROSS-SLOPE SHALL BE SHOWN ELSEWHERE IN THE PLANS. FOR PAVEMENTS WIDER THAN 100 FT. WITHOUT A FREE LONGITUDINAL JOINT, ADDITIONAL DETAIL MAY BE SHOWN ELSEWHERE IN THE PLANS.
2. USE COARSE AGGREGATES WITH A RATED COEFFICIENT OF THERMAL EXPANSION (CoTE) OF NOT MORE THAN 5.5 X 10⁻⁶ IN/IN/°F AS LISTED IN THE CONCRETE RATED SOURCE QUALITY CATALOG (CRSQC).
3. ALL THE REINFORCING STEEL AND TIE BARS SHALL BE DEFORMED STEEL BARS CONFORMING TO ASTM A 615 (GRADE 60) OR ASTM A 996 (GRADE 60) OR ABOVE. STEEL BAR SIZES AND SPACINGS SHALL CONFORM TO TABLE NO.1 AND TABLE NO.2.
4. STEEL BAR PLACEMENT TOLERANCE SHALL BE +/- 1 IN. HORIZONTALLY AND +/- 0.5 IN. VERTICALLY. CALCULATED AVERAGE BAR SPACING (CONCRETE PLACEMENT WIDTH / NUMBER OF LONGITUDINAL BARS) SHALL CONFORM TO TABLE NO.1.
5. ADJUST REINFORCING STEEL VERTICALLY USING SHIMS OR OTHER METHODS, AS APPROVED, TO MEET VERTICAL TOLERANCES PRIOR TO CONCRETE PLACEMENT.
6. PAVEMENT WIDTHS OF MORE THAN 15 FT. SHALL HAVE A LONGITUDINAL JOINT (SECTION Z-Z OR SECTION Y-Y). THESE JOINTS SHALL BE LOCATED WITHIN 6 IN. OF THE LANE LINE UNLESS THE JOINT LOCATION IS SHOWN ELSEWHERE ON THE PLANS.
7. THE MINIMUM PROJECTION OF TIE BARS INTO THE ADJACENT PLACEMENT IS 22.5 IN. FOR #6 BARS AND 18.5 IN. FOR #5 BARS.
8. SEE STANDARD SHEET "CONCRETE CURB AND CURB AND GUTTER," FOR DETAILS WHEN TYING CONCRETE CURB OR CURB GUTTER AT A LONGITUDINAL JOINT.
9. REPLACE MISSING OR DAMAGED TIE BARS WITHOUT ADDITIONAL COMPENSATION BY DRILLING MIN.10 IN. DEEP AND GROUTING TIE BARS WITH TYPE III, CLASS C EPOXY. MEET THE PULL-OUT TEST REQUIREMENTS IN ITEM 361.
10. OMIT TIE BARS LOCATED WITHIN 18-IN. OF THE TRANSVERSE CONSTRUCTION JOINTS (SECTION X-X). USE HAND-OPERATED IMMERSION VIBRATORS TO CONSOLIDATE THE CONCRETE ADJACENT TO ALL FORMED JOINTS.
11. THE DETAIL FOR THE JOINT SEALANT AND RESERVOIR IS SHOWN ON STANDARD SHEET "CONCRETE PAVING DETAILS, JOINT SEALS."
12. LONGITUDINAL REINFORCING STEEL SPLICES SHALL BE A MINIMUM OF 25-IN.

		Design Division Standard	
CONTINUOUSLY REINFORCED CONCRETE PAVEMENT			
ONE LAYER STEEL BAR PLACEMENT			
T - 7 TO 13 INCHES			
CRCP (1) - 24			
FILE: crcp124.dgn	DN: CES	CK: KM	DW: CES
© TxDOT: Sept 2024	CONT	SECT	JOB
REVISTONS	DIST		COUNTY
			SHEET NO.

DATE:
FILE:

DISCLAIMER: The use of this standard is governed by the "Texas Engineering Practice Act". No warranty of any kind is made by TxDOT for any purpose whatsoever. TxDOT assumes no responsibility for the conversion of this standard to other formats or for incorrect results or damages resulting from its use.

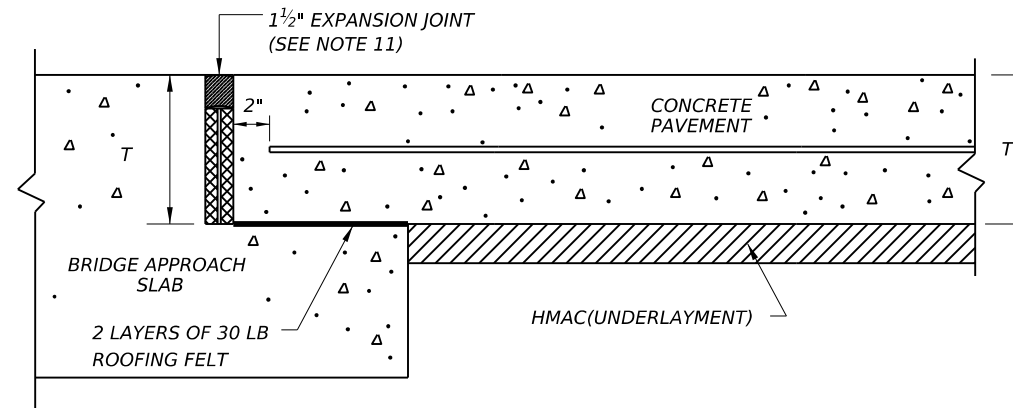

**TRANSVERSE EXPANSION JOINT DETAIL
AT BRIDGE APPROACH**

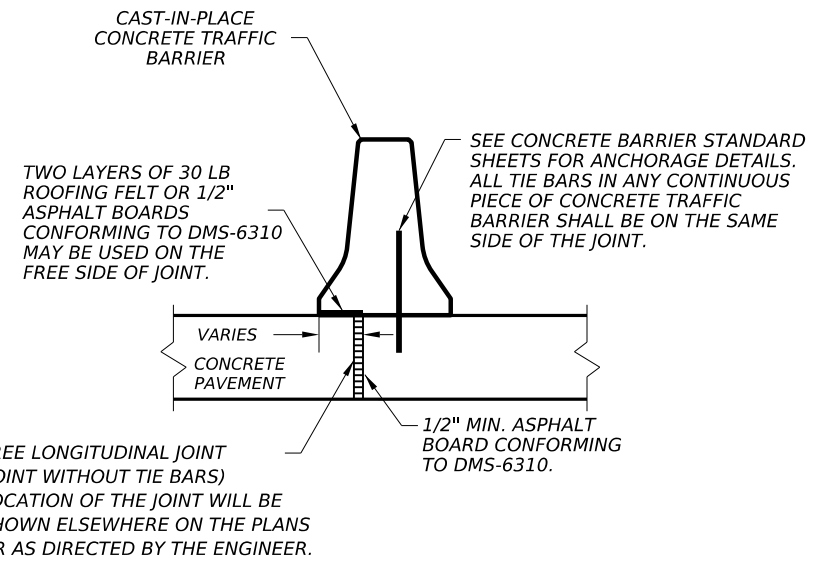

CENTERLINE FREE LONGITUDINAL JOINT DETAIL

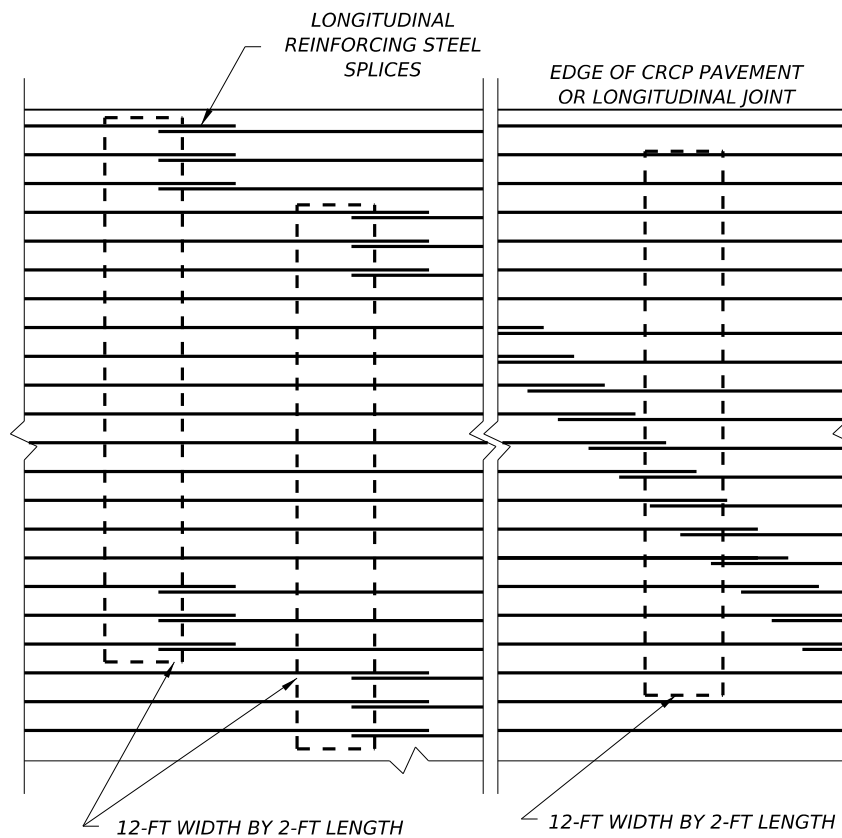

STAGGER THE LAP LOCATIONS SO THAT NO MORE THAN 1/3 OF THE LONGITUDINAL STEEL IS SPLICED IN ANY GIVEN 12-FT. WIDTH AND 2-FT. LENGTH OF THE PAVEMENT. ANY OTHER LAP CONFIGURATION MEETING THIS REQUIREMENT WILL BE ALLOWED.

**EXAMPLES OF LAP CONFIGURATION
PLAN VIEW (NOT TO SCALE)**

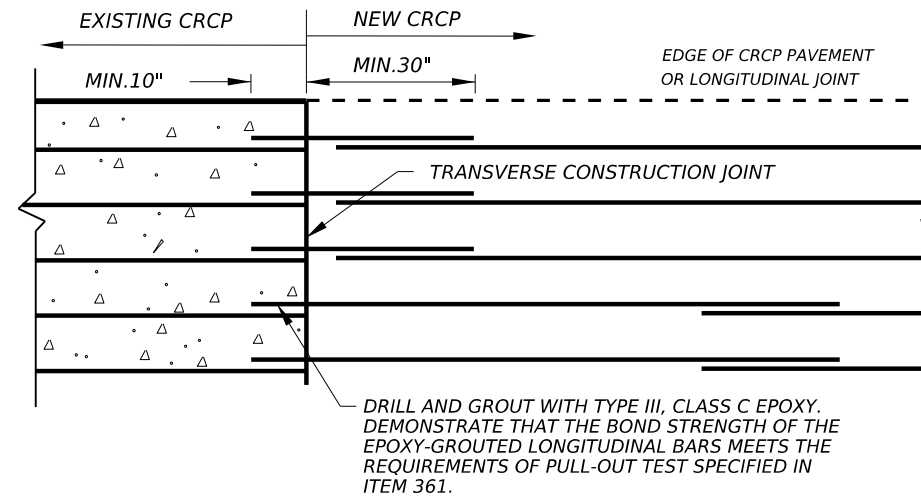

**OPTION A: DRILL AND EPOXY
PLAN VIEW (NOT TO SCALE)**

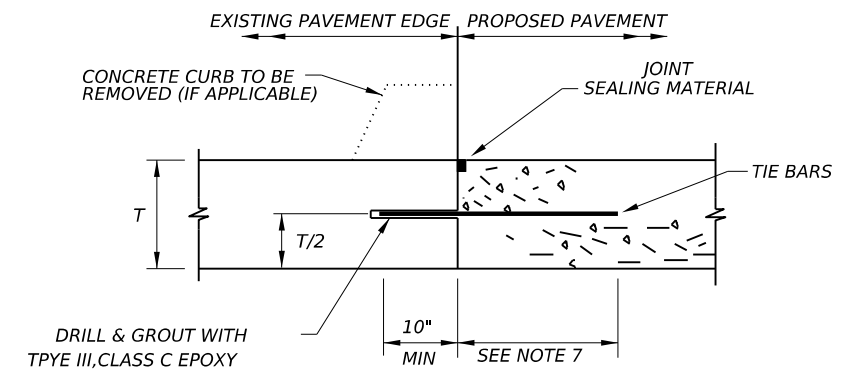

DRILL & GROUT WITH TYPE III, CLASS C EPOXY

- BEFORE CONCRETE PLACEMENT, PERFORM PULL-OUT TESTS ON EPOXY-GROUTED TIE BARS IN ACCORDANCE WITH ITEM 360.
- SPACE TIE BARS AT 24" SPACING. USE #6 TIE BARS FOR 8" AND THICKER PAVEMENTS, USE #5 TIE BARS FOR LESS THAN 8" THICK PAVEMENTS.

LONGITUDINAL WIDENING JOINT DETAIL

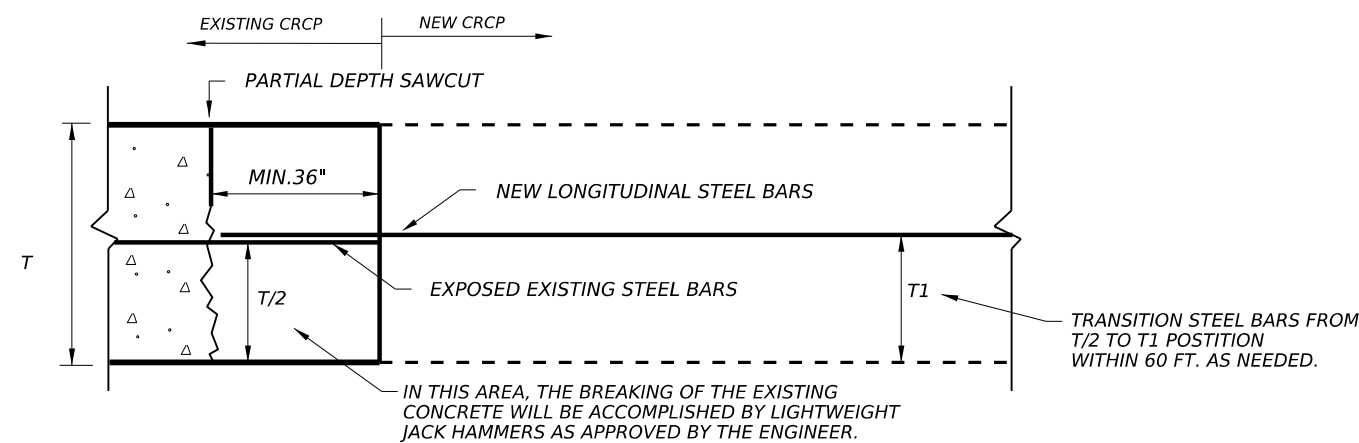

OPTION B: BREAKBACK AND LAP

**TRANSVERSE TIE JOINT DETAIL
NEW CRCP TO EXISTING CRCP**

SHEET 2 OF 2

		Design Division Standard	
CONTINUOUSLY REINFORCED CONCRETE PAVEMENT			
ONE LAYER STEEL BAR PLACEMENT			
T - 7 to 13 INCHES			
CRCP (1) - 24			
FILE: crcp124.dgn	DN: TxDOT	CK: KM	DW: CES
© TxDOT: Sept 2024	CONT	SECT	JOB
REVISIONS			HIGHWAY
	DIST	COUNTY	SHEET NO.

DATE:
FILE: