

DISCLAIMER: The use of this standard is governed by the "Texas Engineering Practice Act". No warranty of any kind is made by TxDOT for any purpose whatsoever. TxDOT assumes no responsibility for the conversion of this standard to other formats or for incorrect results or damages resulting from its use.

TABLE NO. 1 LONGITUDINAL STEEL					
SLAB THICKNESS AND BAR SIZE		FOR BOTH STEEL MATS		FOR TOP STEEL MAT ONLY	
		REGULAR STEEL BARS	FIRST SPACING AT EDGE OR JOINT	ADDITIONAL STEEL BARS AT TRANSVERSE CONSTRUCTION JOINT (SECTION X-X)	
T (IN.)	BAR SIZE	SPACING C (IN.)	SPACING a (IN.)	SPACING 2 x c (IN.)	LENGTH L (IN.)
14	#6	9.5	3 TO 4	19	50
15	#6	8.5	3 TO 4	17	50

TABLE NO. 2 TRANSVERSE STEEL AND TIE BARS						
SLAB THICKNESS T (IN.)	FOR BOTH STEEL MATS		FOR LOWER STEEL MAT ONLY		FOR BOTH STEEL MATS	
	TRANSVERSE STEEL		TIE BARS AT LONGITUDINAL CONSTRUCTION JOINT (SECTION Z-Z)		TIE BARS AT LONGITUDINAL CONSTRUCTION JOINT (SECTION Y-Y)	
	BAR SIZE	SPACING (IN.)	BAR SIZE	SPACING (IN.)	BAR SIZE	SPACING (IN.)
14 - 15	#5	48	#6	48	#6	24

TABLE NO. 3 TWO LAYER STEEL PLACEMENT HEIGHT OF STEEL MATS		
SLAB THICKNESS T (IN.)	LOWER STEEL MAT HEIGHT T1 (IN.)	TOP STEEL MAT HEIGHT T2 (IN.)
14	4.5	8.0
15	5.0	8.5

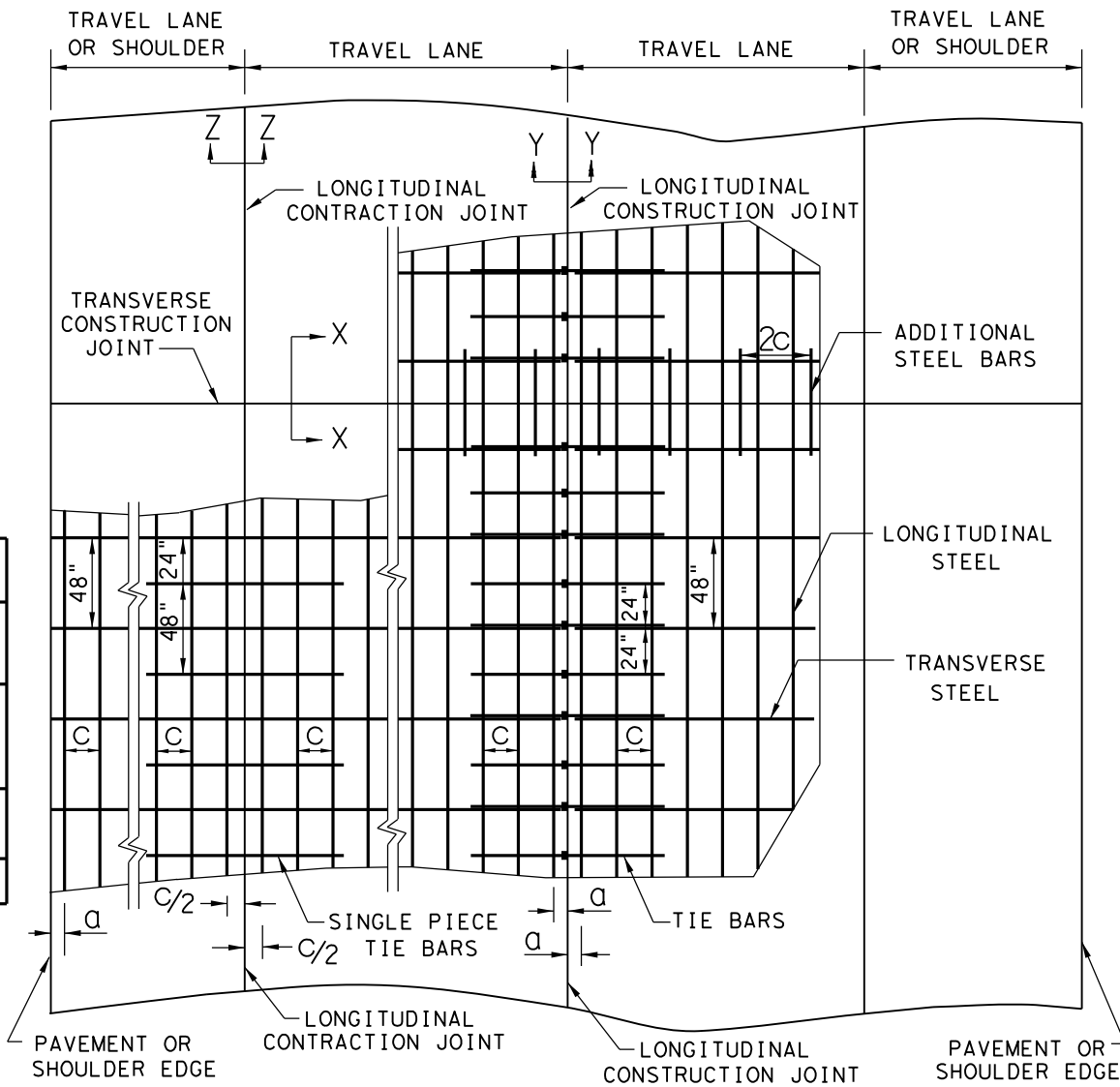

TYPICAL PAVEMENT LAYOUT

PLAN VIEW (NOT TO SCALE)

GENERAL NOTES

1. DETAILS FOR PAVEMENT WIDTH, PAVEMENT THICKNESS AND THE CROWN CROSS-SLOPE SHALL BE SHOWN ELSEWHERE IN THE PLANS. PAVEMENTS WIDER THAN 100 FT. WITHOUT A FREE LONGITUDINAL JOINT ARE NOT COVERED BY THIS STANDARD.
2. USE COARSE AGGREGATES WITH A RATED COEFFICIENT OF THERMAL EXPANSION (COTE) OF NOT MORE THAN 5.5×10^{-6} IN/IN/°F AS LISTED IN THE CONCRETE RATED SOURCE QUALITY CATALOG (CRSQC).
3. ALL THE REINFORCING STEEL AND TIE BARS SHALL BE DEFORMED STEEL BARS CONFORMING TO ASTM A 615 (GRADE 60) OR ASTM A 996 (GRADE 60) OR ABOVE. STEEL BAR SIZES AND SPACINGS SHALL CONFORM TO TABLE NO. 1, TABLE NO. 2 AND TABLE NO. 3.
4. STEEL BAR PLACEMENT TOLERANCE SHALL BE +/- 1 IN. HORIZONTALLY AND +/- 0.5 IN. VERTICALLY. CALCULATED AVERAGE BAR SPACING (CONCRETE PLACEMENT WIDTH / NUMBER OF LONGITUDINAL BARS) SHALL CONFORM TO TABLE NO. 1.
5. PAVEMENT WIDTHS OF MORE THAN 15 FT. SHALL HAVE A LONGITUDINAL JOINT (SECTION Z-Z OR SECTION Y-Y). THESE JOINTS SHALL BE LOCATED WITHIN 6 IN. OF THE LANE LINE UNLESS THE JOINT LOCATION IS SHOWN ELSEWHERE ON THE PLANS.
6. THE SAW CUT DEPTH FOR THE LONGITUDINAL CONTRACTION JOINT (SECTION Z-Z) SHALL BE ONE THIRD OF THE SLAB THICKNESS (T/3).
7. WHEN TYING CONCRETE GUTTER AT A LONGITUDINAL JOINT, THE TIE BAR LENGTH OR POSITION MAY BE ADJUSTED. PROVIDE 3 IN. OF CONCRETE COVER FROM THE BACK OF GUTTER TO THE END OF TIE BAR.
8. REPLACE MISSING OR DAMAGED TIE BARS WITHOUT ADDITIONAL COMPENSATION BY DRILLING MIN. 10 IN. DEEP AND GROUTING TIE BARS WITH TYPE III, CLASS C EPOXY. MEET THE PULL-OUT TEST REQUIREMENTS IN ITEM 361.
9. OMIT TIE BARS LOCATED WITHIN 18 IN. OF THE TRANSVERSE CONSTRUCTION JOINTS (SECTION X-X). USE HAND-OPERATED IMMERSION VIBRATORS TO CONSOLIDATE THE CONCRETE ADJACENT TO ALL FORMED JOINTS.
10. LONGITUDINAL REINFORCING STEEL SPLICES SHALL BE A MINIMUM OF 25 IN. STAGGER THE LAP LOCATIONS SO THAT NO MORE THAN 1/3 OF THE LONGITUDINAL STEEL IS SPLICED IN ANY GIVEN 12-FT. WIDTH AND 2-FT. LENGTH OF THE PAVEMENT.
11. THE DETAIL FOR THE JOINT SEALANT AND RESERVOIR IS SHOWN ON STANDARD SHEET "CONCRETE PAVING DETAILS, JOINT SEALS."

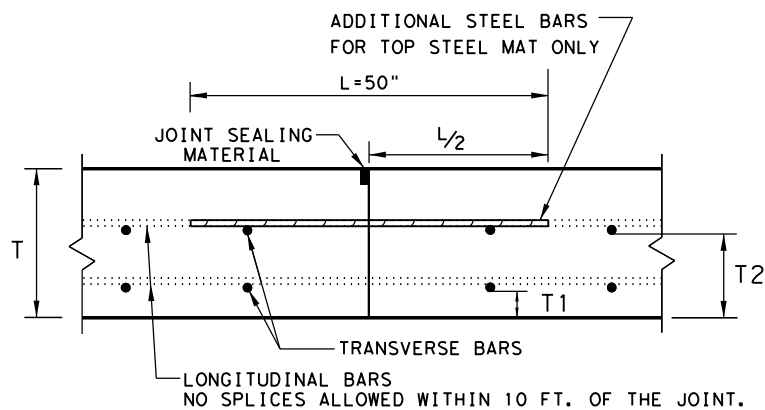

TRANSVERSE CONSTRUCTION JOINT
SECTION X - X

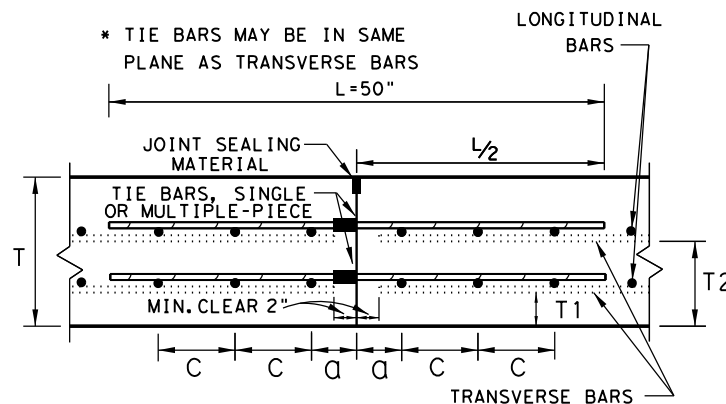

LONGITUDINAL CONSTRUCTION JOINT
SECTION Y - Y

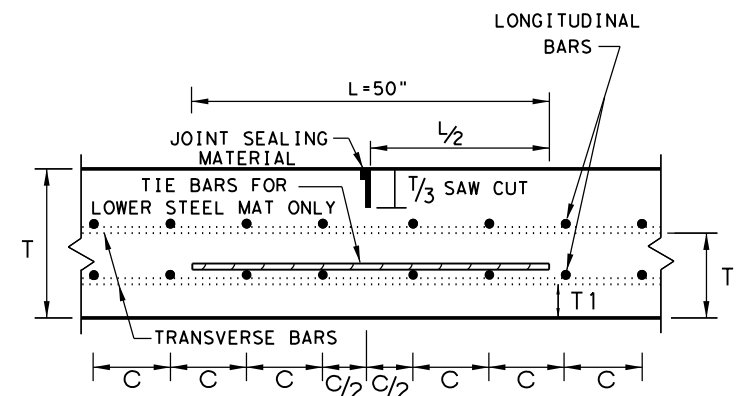

LONGITUDINAL CONTRACTION JOINT
SECTION Z - Z

SHEET 1 OF 2

		Design Division Standard	
CONTINUOUSLY REINFORCED CONCRETE PAVEMENT TWO LAYER STEEL BAR PLACEMENT T - 14 & 15 INCHES CRCP (2) - 20			
FILE: crcp220.dgn	DN: TxDOT	CK: KM	DW: AN
© TxDOT: APRIL 2020	CONT	SECT	JOB
10/10/2011 ADD CW #12			HIGHWAY
04/09/2013 REMOVE 6" AND 6.5" ADD CTE REQUIREMENTS			
04/19/2017 COTE AS RATED 4.3	DIST	COUNTY	SHEET NO.

DATE: FILE:

DISCLAIMER: This standard is governed by the "Texas Engineering Practice Act". No warranty of any kind is made by TxDOT for any purpose whatsoever. TxDOT assumes no responsibility for the conversion of this standard to other formats or for incorrect results or damages resulting from its use.

DATE:
FILE:

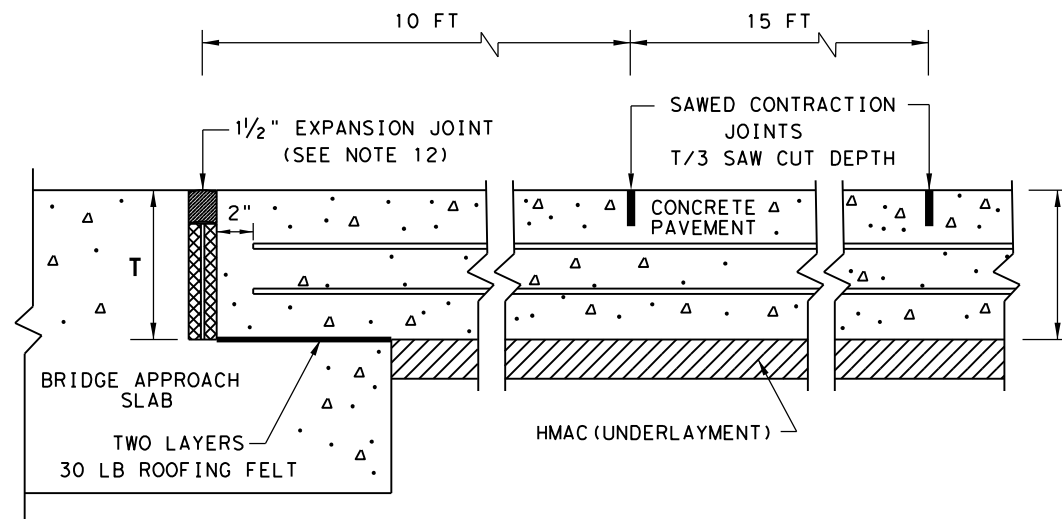

**TRANSVERSE EXPANSION JOINT DETAIL
AT BRIDGE APPROACH**

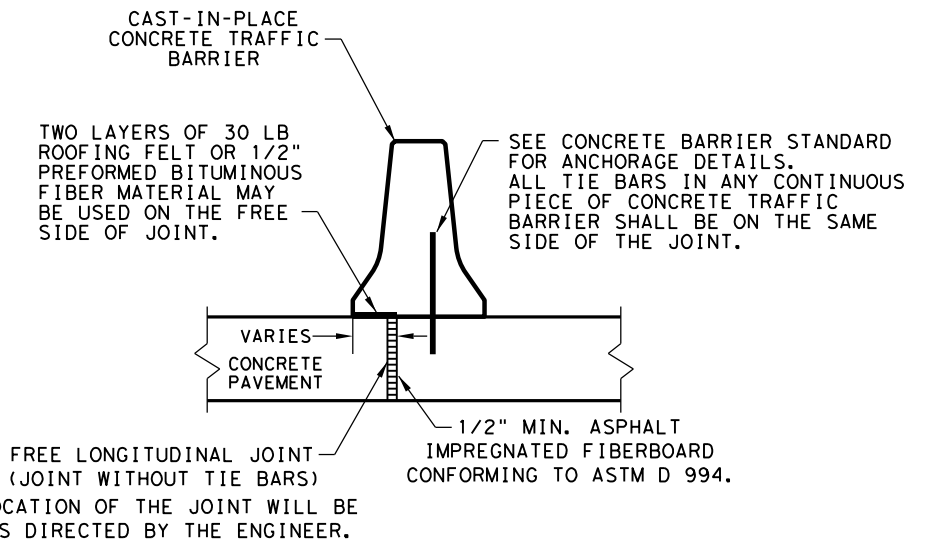

FREE LONGITUDINAL JOINT DETAIL

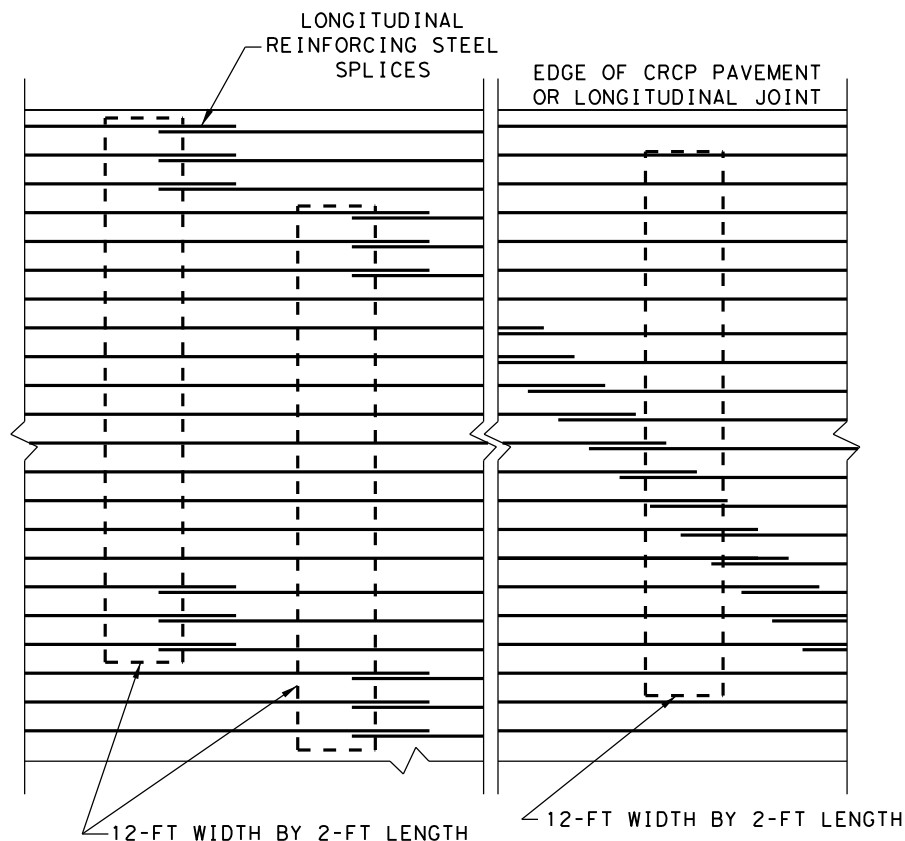

**EXAMPLES OF LAP CONFIGURATION
PLAN VIEW (NOT TO SCALE)**

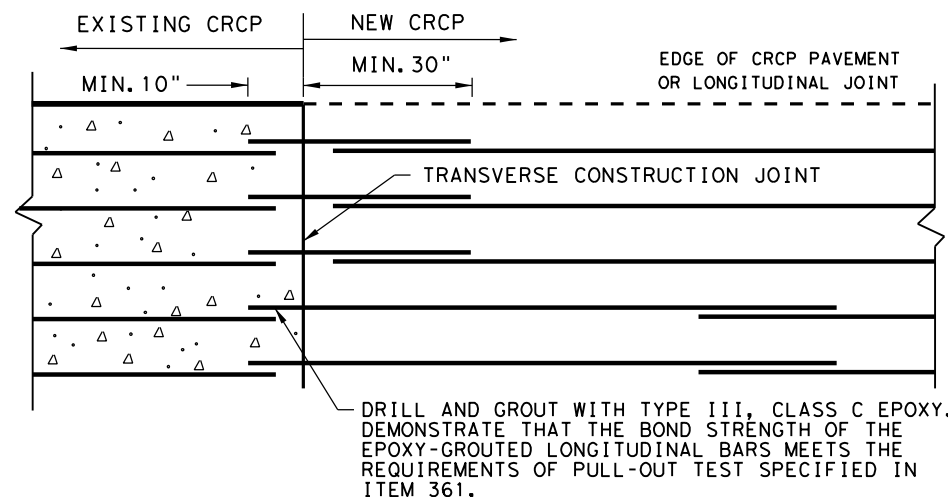

**OPTION A: DRILL AND EPOXY
PLAN VIEW (NOT TO SCALE)**

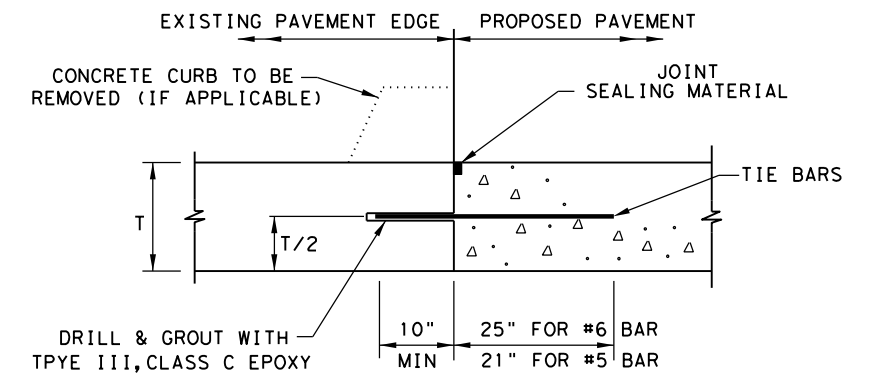

1. BEFORE WIDENING WORK, DEMONSTRATE THAT THE BOND STRENGTH OF THE EPOXY-GROUTED TIE BARS MEETS THE REQUIREMENTS OF PULL-OUT TEST SPECIFIED IN ITEM 361.
2. SPACE TIE BARS AT 24" SPACING. USE #6 TIE BARS FOR 8" AND THICKER SLABS, USE #5 TIE BARS FOR LESS THAN 8" THICK SLABS.

LONGITUDINAL WIDENING JOINT DETAIL

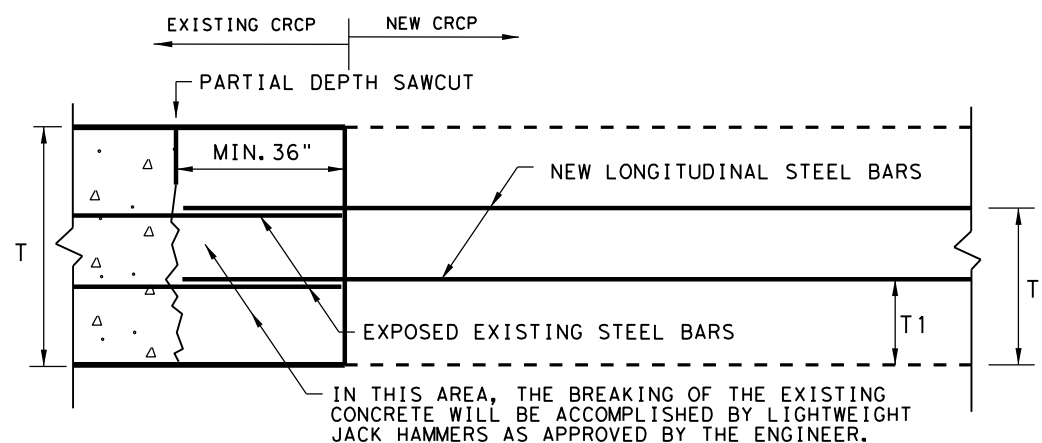

**OPTION B: BREAKBACK AND LAP
TRANSVERSE TIE JOINT DETAIL
EXISTING CRCP TO NEW CRCP**

SHEET 2 OF 2

		Design Division Standard	
CONTINUOUSLY REINFORCED CONCRETE PAVEMENT			
TWO LAYER STEEL BAR PLACEMENT			
T - 14 & 15 INCHES			
CRCP (2) - 20			
FILE: crcp220.dgn	DN: TxDOT	CK: KM	DW: AN
© TxDOT: APRIL 2020	CONT	SECT	JOB
REVISIONS	DIST		COUNTY
03/16/2020 REMOVED TABLE 1A			SHEET NO.