

DISCLAIMER: The use of this standard is governed by the "Texas Engineering Practice Act". No warranty of any kind is made by TxDOT for any purpose whatsoever. TxDOT assumes no responsibility for the conversion of this standard to other formats or for incorrect results or damages resulting from its use.

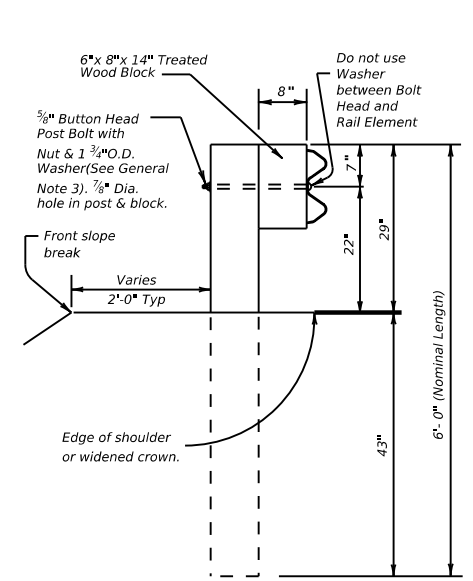

TYPICAL POST

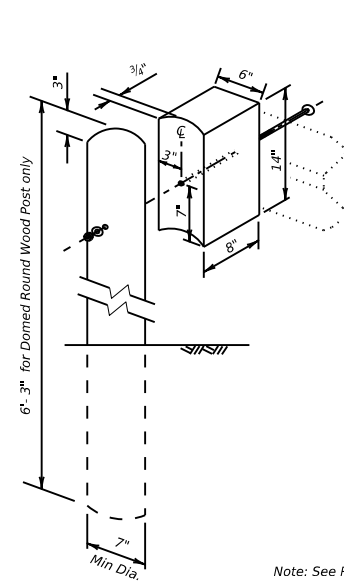

WOOD BLOCK TO ROUND WOOD POST

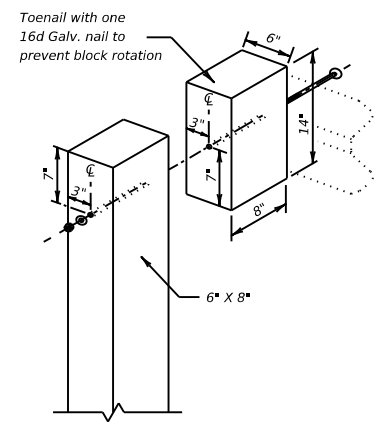

WOOD BLOCK TO RECTANGULAR WOOD POST

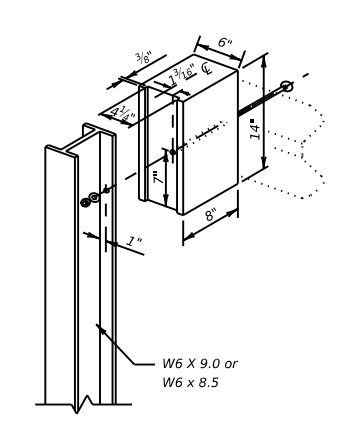

WOOD BLOCK TO STEEL POST

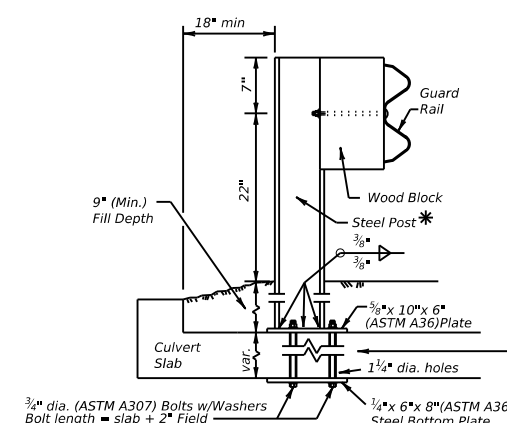

LOW FILL CULVERT POST FOR USE ON NON-BRIDGE CLASS CULVERTS ONLY

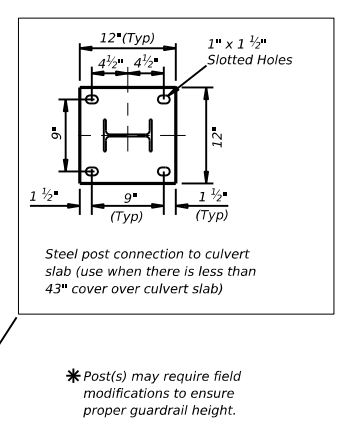

Steel post connection to culvert slab (use when there is less than 43\"/>

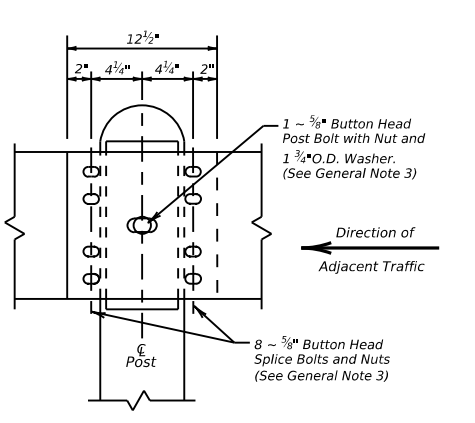

RAIL SPLICE DETAIL

Note: See Rail Splice Detail for the required hardware.

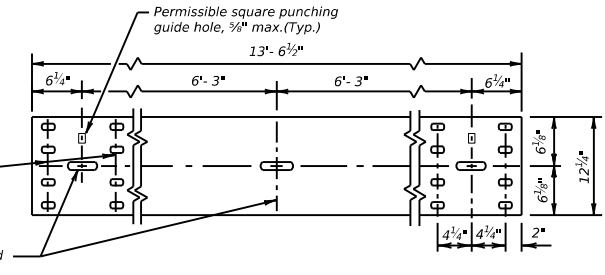

ELEVATION 12 1/2\"/>

GENERAL NOTES

- The type of post (round wood post, rectangular wood post, or steel post) will be shown elsewhere in the plans. The exact position of MBGF shall be shown elsewhere in the plans or as directed by the Engineer. Steel posts to be galvanized in accordance with Item 445, "Galvanizing."
- Rail element shall meet the requirements of Item 540, "Metal Beam Guard Fence" except as modified on the plans. The Contractor may furnish rail elements of 12 1/2' or 25 foot nominal lengths.
- Button head "post" bolts (ASTM A307) shall be of sufficient length to extend through the full thickness of the nut (ASTM A563) and Type A (1 3/4" O.D.) washer and not more than 1" beyond it. Button head "splice" bolts (ASTM A307) are 5/8" x 1 3/4" (or 2" long at triple rail splices) with a 5/8" double recessed nut (ASTM A563).
- Fittings (bolts, nuts, and washers) shall be galvanized in accordance with Item 445, "Galvanizing." Fittings shall be subsidiary to the bid item.
- Crown shall be widened to accommodate the Metal Beam Guard Fence.
- The lateral approach to the guard fence, shall have a slope rate of not more than 1V:10H.
- Unless otherwise shown in the plans, guard fence placed in the vicinity of curbs shall be positioned so that the face of curb is located directly below or behind the face of the block. Rail placed over curbs shall be installed so that the post bolt is located approximately 21 inches above the gutter pan or roadway surface.
- If solid rock is encountered within 0 to 18" of the finished grade, drill a 22" dia. hole, 24" into the rock, or drill two 12" dia. front to back overlapping holes, 24" into the rock. If solid rock is encountered below 18", drill a 12" dia. hole, 12" into the rock or to the standard embedment depth, whichever is less. Any excess post length, after meeting these depths, may be field cut to ensure proper guardrail mounting height. Backfill with a cohesionless material.
- Posts shall not be set in concrete, of any depth.
- Special fabrication will be required at installations having a curvature of less than 150 ft. radius.
- The terminal anchor section (TAS) post shall be set in Class A concrete (unless otherwise shown in the plans) in accordance with Item 421, "Hydraulic Cement Concrete." Concrete shall be subsidiary to the bid item requiring construction of the terminal anchor section (TAS). Terminal anchor post to be galvanized in accordance with Item 445, "Galvanizing."
- Unless otherwise shown in the plans, a composite material post and/or block that meets the requirements of DMS-7210, "Composite Material Posts and Blocks for Metal Beam Guard Fence" may be substituted for posts and/or blocks of similar dimensions. The Construction Division, TxDOT maintains a Material Producer List (MPL) for producers of materials conforming to DMS-7210. Only producers on the MPL can furnish composite material posts and/or blocks.

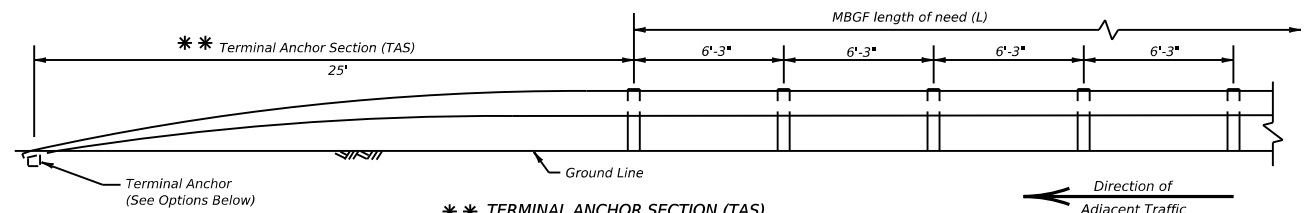

Terminal Anchor Section (TAS)

Terminal anchor sections are only for downstream use, when located outside the horizontal clearance area of opposing traffic.

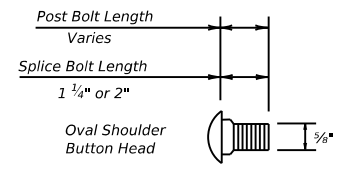

BUTTON HEAD BOLT Post and Splice Bolts (See General Note 3)

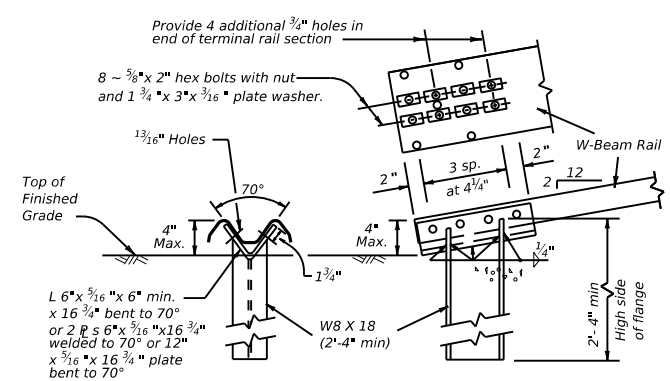

OPTION (1)

Note: This anchor post requires four additional 3/4\"/>

TERMINAL ANCHOR POST OPTIONS (See General Note 11)

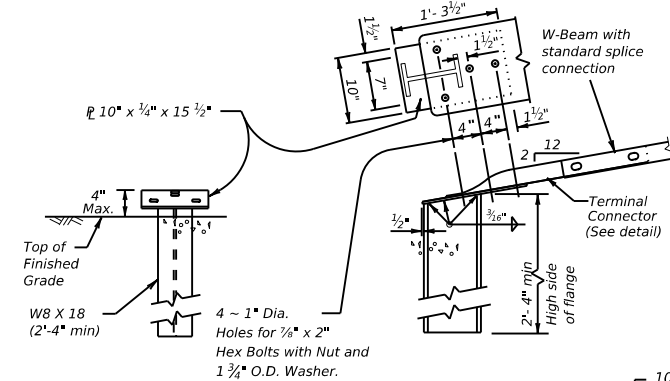

OPTION (2)

Note: This anchor post requires the use of the 10 ga. terminal connector with four 5/8\"/>

Notes: Either concrete anchor may be used with either post option above. No construction joint is allowed in the concrete anchor. Terminal rail may be bolted to post and in twist position prior to placing concrete anchor. If concrete anchor is precast, the area should be compacted as directed by the Engineer, when placed in the field.

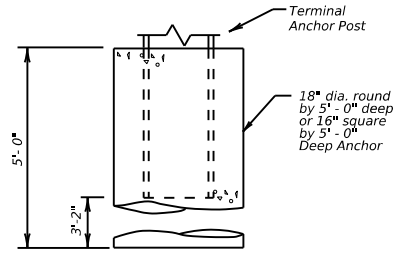

TERMINAL CONCRETE ANCHOR OPTIONS (See General Note 11)

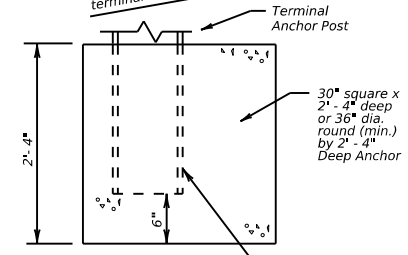

Place face of post approx. on C of anchor

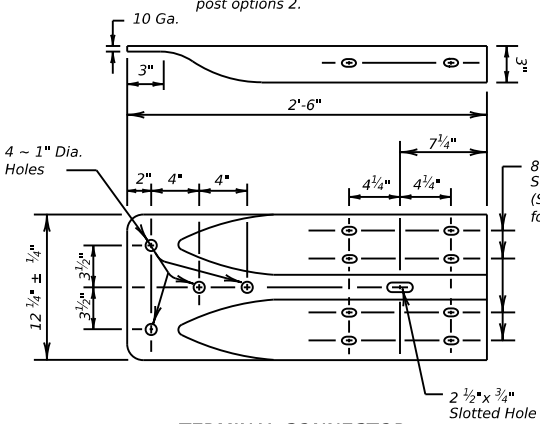

TERMINAL CONNECTOR

For connection hardware to concrete rails, see the MBGF transition standards.

ONLY FOR USE IN MAINTENANCE REPAIRS OR HIGHLY CONSTRAINED SITE CONDITIONS.

Texas Department of Transportation Design Division Standard

METAL BEAM GUARD FENCE

MBGF - 19

FILE: mbgf19.dgn	DN: TxDOT	CK: KM	DW: BD	CK: VP
© TxDOT NOVEMBER 2019	CONT	SECT	JOB	HIGHWAY
REVISIONS				
	DIST	COUNTY		SHEET NO.

DATE: FILE: