

DISCLAIMER: The use of this standard is governed by the "Texas Engineering Practice Act". No warranty of any kind is made by TxDOT for any purpose whatsoever. TxDOT assumes no responsibility for the conversion of this standard to other formats or for incorrect results or damages resulting from its use.

DATE: FILE:

TABLE NO.1 STEEL BAR SIZE AND SPACING						
TYPE PAVEMENT	SLAB THICKNESS AND BAR SIZE		LONGITUDINAL*		TRANSVERSE*	
			REGULAR BARS	TIEBARS	BARS	TIEBARS
	T (IN.)	BAR SIZE	SPACING (IN.)	SPACING (IN.)	SPACING (IN.)	SPACING (IN.)
CRCP	6.0	#5	7.5	7.5	24	24
	6.5		7.0	7.0		
	7.0		6.5	6.5		
	7.5		6.0	6.0		
	8.0	#6	9.0	9.0	24	24
	8.5		8.5	8.5		
	9.0		8.0	8.0		
	9.5		7.5	7.5		
	10.0		7.0	7.0		
	10.5		6.75	6.75		
	11.0		6.5	6.5		
11.5	6.25	6.25				
≥12.0	6.0	6.0				
JRCP	<8.0	#5	24.0	12.0	24	24
	≥8.0	#6	24.0	12.0	24	24
CPCD	<8.0	#5	NONE	12.0	NONE	24
	≥8.0	#6	NONE	12.0	NONE	24

* USE 12" SPACING AS FIRST AND LAST SPACING AT END OR SIDE FOR ALL BARS.

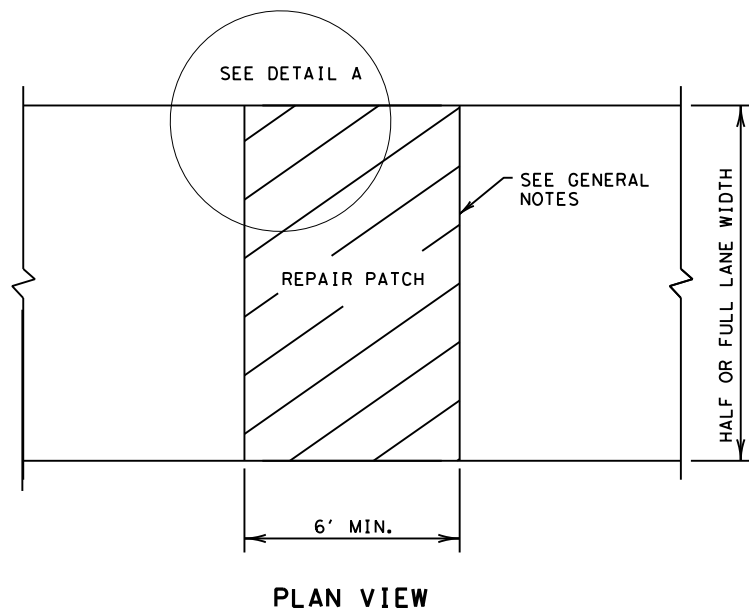

GENERAL NOTES

- ITEM 361, "REPAIR OF CONCRETE PAVEMENT" SHALL GOVERN FOR THIS WORK.
- MULTIPLE PIECE TIEBARS SHALL BE USED WHEN THE REPAIR AREA MUST BE PLACED IN TWO STAGES DUE TO SEQUENCE OF CONSTRUCTION.
- FULL DEPTH SAW CUTS SHALL BE MADE AROUND THE PERIMETER OF THE AREA TO BE REPAIRED. THE CUT SHALL BE MADE AT A RIGHT ANGLE TO THE PAVEMENT EDGE AND TO THE CENTER LINE OF THE PAVEMENT.
- AT LEAST ONE LONGITUDINAL FULL DEPTH SAW CUT SHALL BE AT AN EXISTING LONGITUDINAL JOINT.
- ADDITIONAL SAW CUTS MAY BE REQUIRED WITHIN THE AREA OF THE REPAIR TO FACILITATE REMOVAL OF THE CONCRETE OR TO ALLEVIATE BINDING OF THE FULL DEPTH SAW CUT AT THE REPAIR EDGE.
- THE SAW CUTS WHICH EXTEND OUTSIDE THE AREA OF THE REPAIR WILL BE CLEANED AND FILLED WITH A CEMENTITIOUS GROUT APPROVED BY THE ENGINEER.
- EXISTING LONGITUDINAL AND TRANSVERSE JOINTS REMOVED DUE TO REPAIR OPERATION SHOULD BE RESTORED IN ACCORDANCE WITH STANDARD SHEET "CONCRETE PAVING DETAILS, JOINT SEALS."

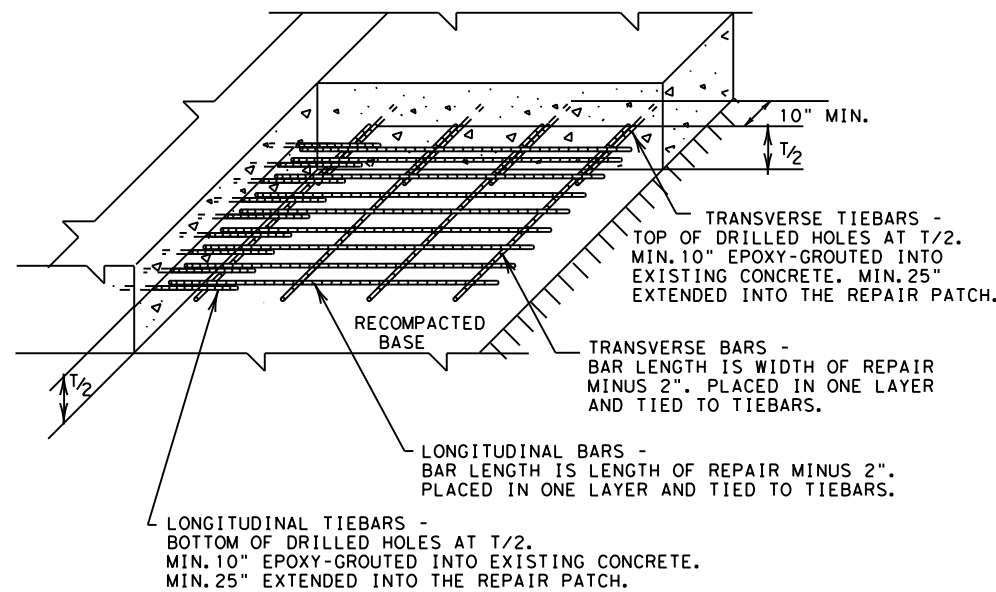

DETAIL A
GROUTED TIEBARS & REINFORCEMENT

FULL-DEPTH REPAIR OF CRCP, JRCP, AND CPCD

GENERAL NOTES

- ITEM 361, "REPAIR OF CONCRETE PAVEMENT" SHALL GOVERN FOR THIS WORK.
- THE SAW CUTS WHICH EXTEND OUTSIDE THE AREA OF THE REPAIR WILL BE CLEANED AND FILLED WITH A CEMENTITIOUS GROUT APPROVED BY THE ENGINEER.
- EXISTING LONGITUDINAL AND TRANSVERSE JOINTS REMOVED DUE TO REPAIR OPERATION SHOULD BE RESTORED IN ACCORDANCE WITH STANDARD SHEET "CONCRETE PAVING DETAILS, JOINT SEALS."

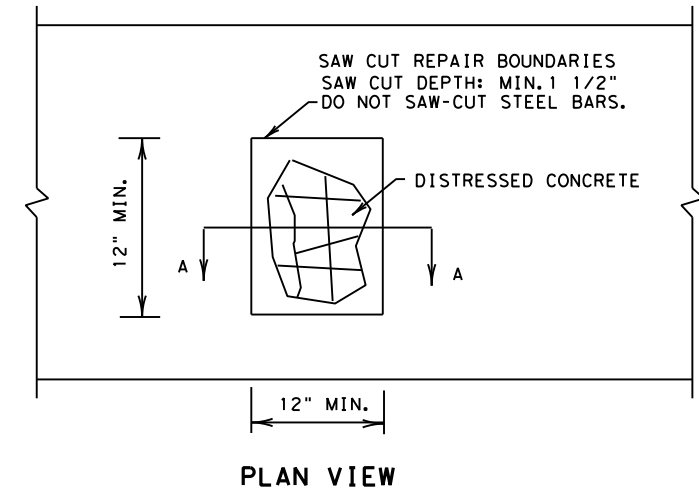

PLAN VIEW

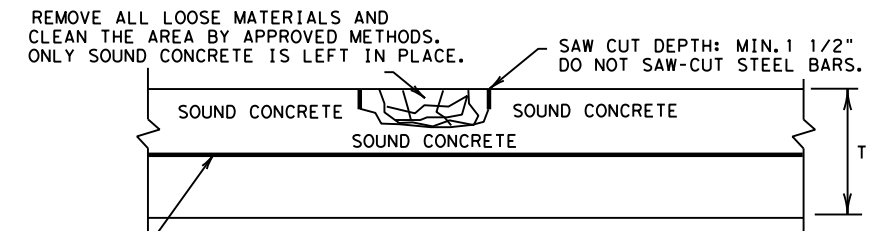

LONGITUDINAL STEEL BARS:

*REPAIR AREAS MAY BE ADJUSTED AFTER REMOVING DISTRESSED CONCRETE. SWITCH THE HALF-DEPTH REPAIR TO FULL-DEPTH REPAIR IF EXPOSED EXISTING LONGITUDINAL BARS ARE DEFICIENT, AS APPROVED. COMPENSATION WILL BE MADE FOR UNEXPECTED VOLUMES OF REPAIR AREAS OR CHANGES IN SCOPE OF WORK.

*INCREASE THE REPAIR AREA AND PERFORM A FULL-DEPTH REPAIR AS DIRECTED IF LONGITUDINAL STEEL BARS WERE DAMAGED BY THE REMOVAL OPERATIONS. NO ADDITIONAL COMPENSATION WILL BE MADE.

SECTION A-A
HALF-DEPTH REPAIR

SHEET 1 OF 2



REPAIR OF CONCRETE PAVEMENT

REPCP-14

FILE: repcp14.dgn	DN: TxDOT	DN: HC	DW: HC	CK: AN
© TxDOT: DECEMBER 2014	CONT	SECT	JOB	HIGHWAY
REVISIONS	DIST	COUNTY	SHEET NO.	

DISCLAIMER: The use of this standard is governed by the "Texas Engineering Practice Act". No warranty of any kind is made by TxDOT for any purpose whatsoever. TxDOT assumes no responsibility for the conversion of this standard to other formats or for incorrect results or damages resulting from its use.

DATE:
FILE:

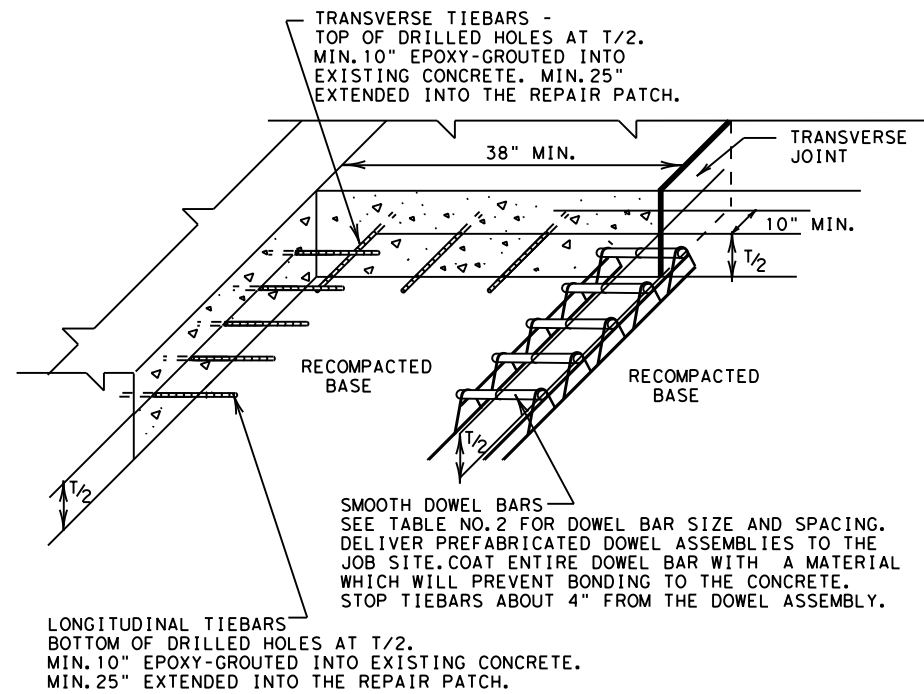
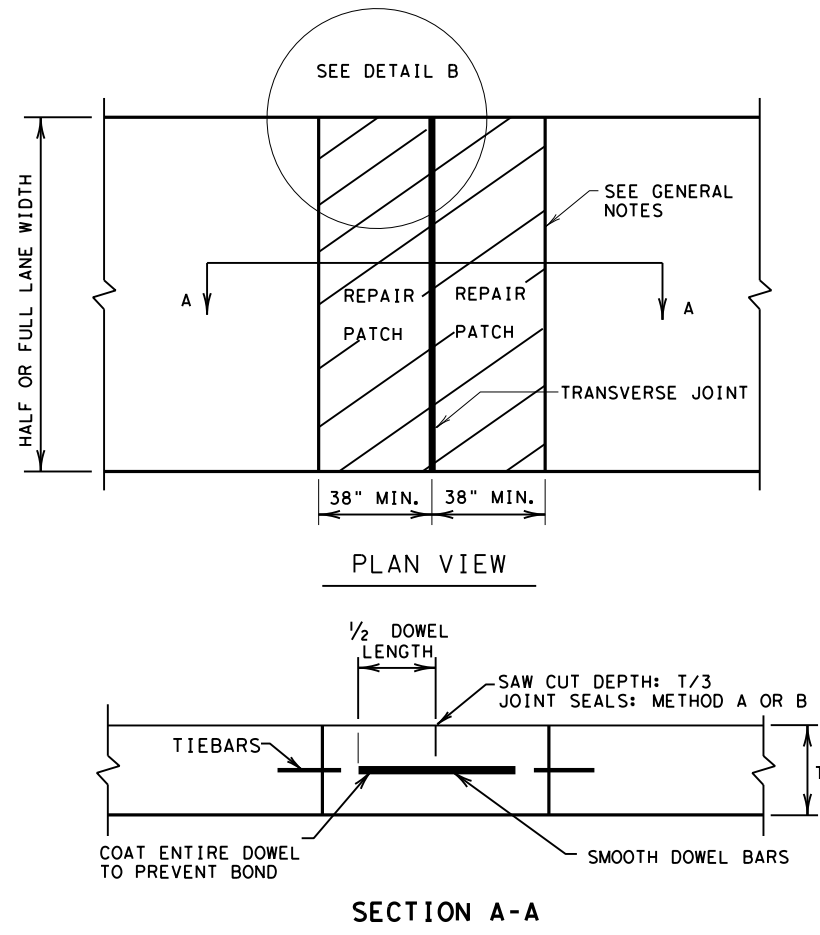

DETAIL B
GROUTED TIEBARS & DOWELS

REPAIR OF TRANSVERSE JOINT OF CPCD

GENERAL NOTES

1. ITEM 361, "REPAIR OF CONCRETE PAVEMENT" SHALL GOVERN FOR THIS WORK.
2. MULTIPLE PIECE TIEBARS SHALL BE USED WHEN THE REPAIR AREA MUST BE PLACED IN TWO STAGES DUE TO SEQUENCE OF CONSTRUCTION.
3. FULL DEPTH SAW CUTS SHALL BE MADE AROUND THE PERIMETER OF THE AREA TO BE REPAIRED. THE CUT SHALL BE MADE AT A RIGHT ANGLE TO THE PAVEMENT EDGE AND TO THE CENTER LINE OF THE PAVEMENT.
4. AT LEAST ONE LONGITUDINAL FULL DEPTH SAW CUT SHALL BE AT AN EXISTING LONGITUDINAL JOINT.
5. ADDITIONAL SAW CUTS MAY BE REQUIRED WITHIN THE AREA OF THE REPAIR TO FACILITATE REMOVAL OF THE CONCRETE OR TO ALLEVIATE BINDING OF THE FULL DEPTH SAW CUT AT THE REPAIR EDGE.
6. THE SAW CUTS WHICH EXTEND OUTSIDE THE AREA OF THE REPAIR WILL BE CLEANED AND FILLED WITH A CEMENTITIOUS GROUT APPROVED BY THE ENGINEER.
7. EXISTING LONGITUDINAL AND TRANSVERSE JOINTS REMOVED DUE TO REPAIR OPERATION SHOULD BE RESTORED IN ACCORDANCE WITH STANDARD SHEET "CONCRETE PAVING DETAILS, JOINT SEALS."
8. DOWEL BAR PLACEMENT TOLERANCE SHALL BE +/- 1/4 IN. HORIZONTALLY AND VERTICALLY UNLESS OTHERWISE SPECIFIED. WHERE DOWEL BAR BASKETS ARE USED, REMOVE THE SHIPPING WIRES.

PAVEMENT THICKNESS (INCHES)	SIZE AND DIA.	LENGTH (IN.)	SPACING (IN.)
<10	#8 (1 IN.)	18.0	12.0
≥10	#10 (1 1/4 IN.)		

SHEET 2 OF 2



REPAIR OF CONCRETE PAVEMENT

REPCP-14

FILE: repcp14.dgn	DN: TxDOT	DN: HC	DW: HC	CK: AN
© TxDOT: DECEMBER 2014	CONT	SECT	JOB	HIGHWAY
REVISIONS				
	DIST	COUNTY		SHEET NO.