

DISCLAIMER: The use of this standard is governed by the "Texas Engineering Practice Act". No warranty of any kind is made by TxDOT for any purpose whatsoever. TxDOT assumes no responsibility for the conversion of this standard to other formats or for incorrect results or damages resulting from its use.

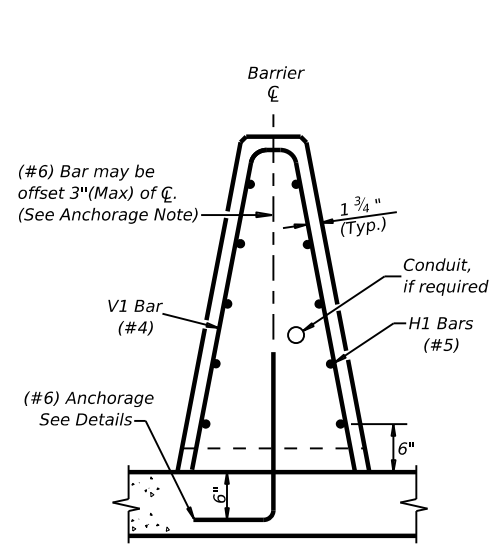

**END VIEW**

**CAST-IN-PLACE (CIP) BARRIER**  
Barrier is Symmetrical About the Center Line

Top edges of CIP barrier shall have a 3/4 inch chamfer or tooled radius.

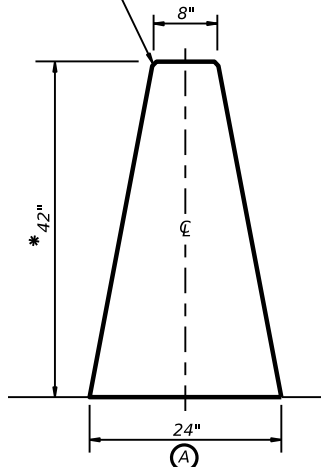

**SINGLE SLOPE CONCRETE BARRIER**  
(SSCB)(42")

* Barrier height (IN.)	Dimensions (IN.)		
(IN.)	(A)	(B)	(C)
42	24	40 1/4	20 1/2
48	26 1/4	46 1/4	22 3/4
54	28 1/2	52 1/4	25 1/16

\* (SSCB)(42") Barrier height may be increased to 48" or 54". This would increase the barrier and reinforcement dimensions accordingly.

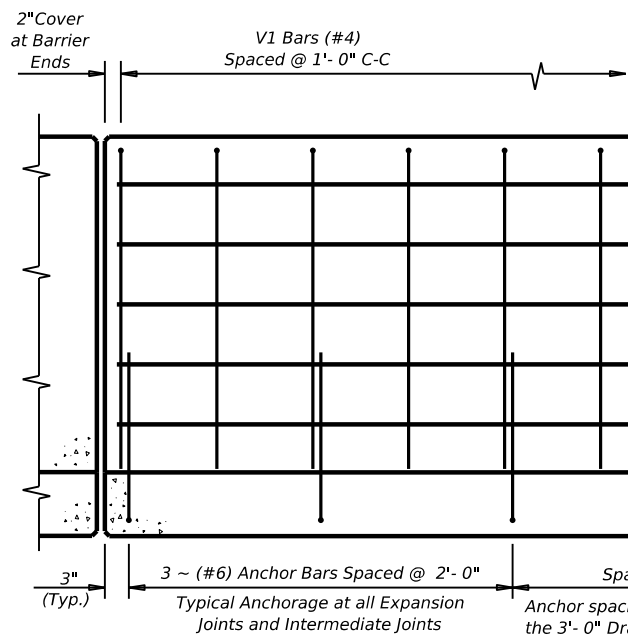

**ELEVATION VIEW**

Cast-in-Place (SSCB) on Bridge Decks or Continuously Reinforced Concrete Pavement (CRCP) (Showing Reinforcement and Anchor Placement)

**BARRIER PLACEMENT OVER (CRCP) JOINTS**  
Barrier may be cast over a "Longitudinal" CRCP joint.

**CRCP Joints (with or without tiebars):** Two layers of 30 lb roofing felt or 1/2" preformed bituminous fiber material.

**Barrier Anchorage Note:** Anchorage must be located at least 3" from a longitudinal joint.

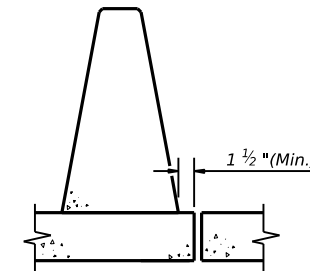

**MINIMUM EDGE DISTANCE FROM LONGITUDINAL JOINT**

Barrier placement over a longitudinal bridge joint is not recommended.

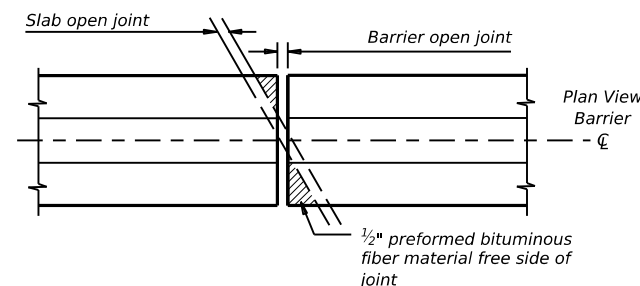

**BARRIER OVER TRANSVERSE OPEN JOINT**

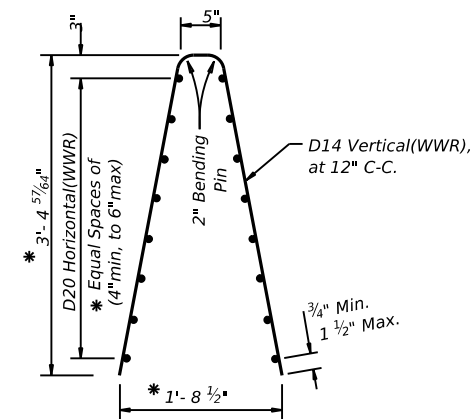

**Welded Wire Reinforcement (WWR) Option for Bars V1 and H1**

(WWR) General Notes

- Deformed Welded Wire Reinforcement (WWR) shall conform to ASTM A497.
- Welded wire cage may be cut and bent to accommodate the drainage slots, as directed by the Engineer.
- Welded wire splice locations shall have a "minimum" splice lap length of 12".
- Combinations of reinforcing steel and WWR will be permitted, as directed by the Engineer. The dimension from the end of the barrier section to the first wire shall not exceed 3".

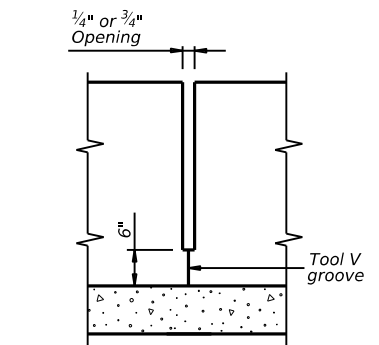

**INTERMEDIATE JOINT DETAIL**

Place at all Bent C's, without expansion joints and spaced at 33 ft. (max), 10 ft. (min).

**EXPANSION JOINT PLACEMENT**

Place at all transverse joints or 100 ft. (max), 10 ft. (min).

**General Notes**

- Concrete shall be Class C. Unless otherwise specified in the plans.
- Where used, rebar reinforcement shall be Grade 60 and conform to ASTM A615. If the bridge slab requires epoxy "coated" reinforcement, the barrier and/or anchorage may require the same, if shown elsewhere in the plans.
- These details cover barrier per Item 514, "Permanent Concrete Traffic Barrier".
- Anchorage: The "Optional" Anchor system shall be embedded 6" into fresh concrete or using a Type III, Class C Epoxy anchorage system. Follow the manufacturer's directions for installing the expoxied anchor bars. All anchorage shown is the minimum required, and considered subsidiary to the bid item.
- Top edges of CIP barrier shall have a 3/4 inch chamfer or tooled radius.
- Drainage slot locations (12'-0 inch, C-C Min. Spacing) are shown elsewhere, or as directed by the Engineer. Drainage slot heights on the SSCB may be increased to a maximum of 5 inches, without geometric changes to the barrier face.
- Cast-in-place barrier may be slip formed. Bracing may be tied or tack welded to the reinforcement cage to provide cage stability. Do not weld to anchor bars. The reinforcement cage may rest on the top of the finished grade.
- For locations where lighting is required, see the SSCB(4) sheet for the proper reinforcement and anchorage.

**Cast-In-Place (CIP) or Slip-Formed (SSCB)**

Cast-in-Place barrier may be connected to precast SSCB. Joint connection "Types" may be used in Cast-in-Place barrier, to match the precast barrier connection. (See required connection "Type" elsewhere in the plans)

The weight of Cast-in-Place (SSCB)42" is approx. 717 lbs per ft.

**Standard Anchorage Note:**  
10" leg may be oriented 90 degrees in any direction about the barrier centerline.

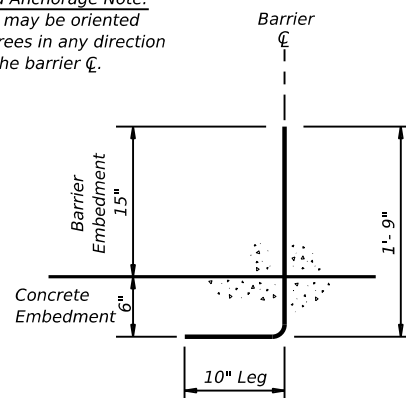

**STANDARD ANCHORAGE**

(#6) Bar

Concrete Pavement / Bridge Deck Anchorage:  
Cast-in-Place or Slip-Formed Barrier  
(See General Notes 2)

**Epoxy Note:**  
If epoxy coated anchor bars are required, the lower 6" of the bars must not be epoxy coated.

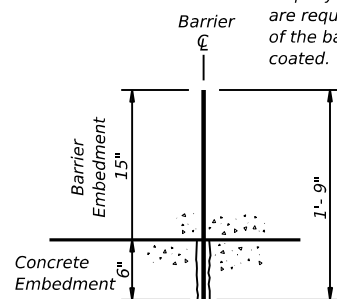

**"OPTIONAL" ANCHORAGE**

(#6) Bar

Fresh insertion method or Type III, Class C Epoxy Method  
Concrete Pavement / Bridge Deck Anchorage:  
Cast-in-Place or Slip-Formed Barrier  
(See General Notes 2 & 4)

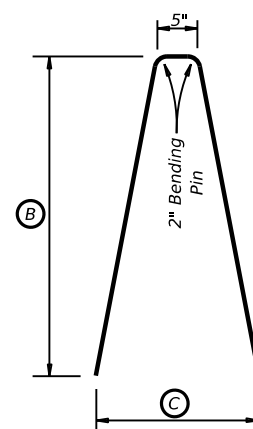

V1 Bar

(#4) Bar

**Texas Department of Transportation**

**SINGLE SLOPE CONCRETE BARRIER**  
CAST-IN-PLACE (TYPE 1)  
(BRIDGE DECK OR CRCP)  
**SSCB (1) - 16**

FILE: sscb116.dgn	DN: TxDOT	CK: HC/AN	DW: BD/VP	CK: KM
© TxDOT January 2016	CONT	SECT	JOB	HIGHWAY
REVISIONS				
CST 01-2016	DIST	COUNTY	SHEET NO.	

DATE: FILE: