

DISCLAIMER: The use of this standard is governed by the "Texas Engineering Practice Act". No warranty of any kind is made by TxDOT for any purpose whatsoever. TxDOT assumes no responsibility for the conversion of this standard to other formats or for incorrect results or damages resulting from its use.

DATE:
FILE:

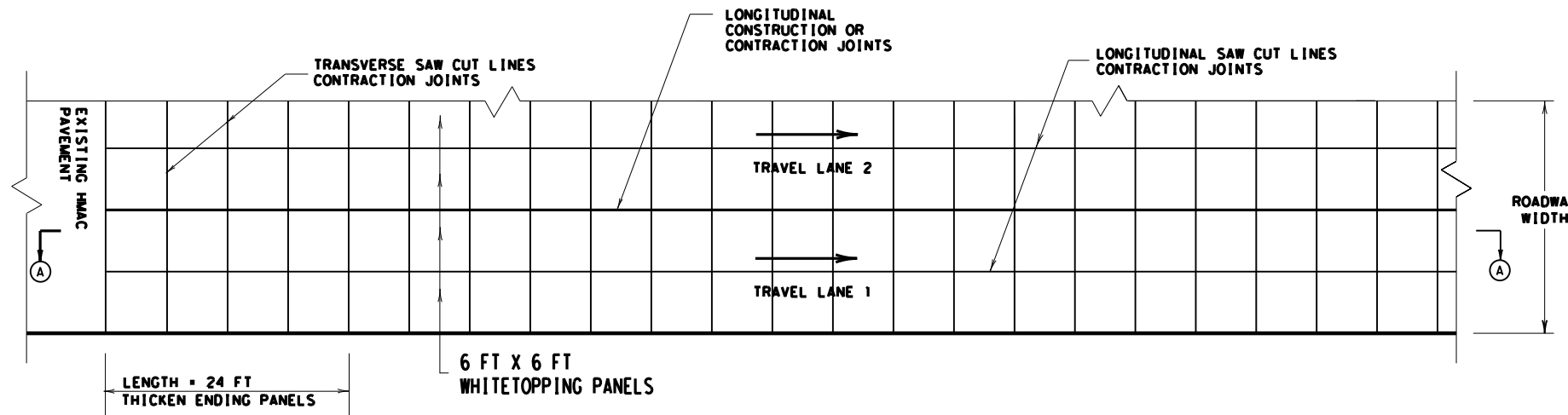

TYPICAL LAYOUT FOR 4" TO 7" THICK OVERLAY
(NOT TO SCALE)

GENERAL NOTES

1. WHITETOPPING CONCRETE OVERLAY LESS THAN 4 INCHES THICK, ARE NOT COVERED BY THIS STANDARD.
2. FOR FURTHER INFORMATION REGARDING THE PLACEMENT OF CONCRETE REFER TO THE GOVERNING SPECIFICATIONS FOR "CONCRETE PAVEMENT."
3. DETAILS FOR PAVEMENT WIDTH, PAVEMENT THICKNESS, AND CROWN CROSS SLOPE SHALL BE SHOWN ELSEWHERE IN THE PLAN.
4. THE SAWED JOINT SPACINGS SHALL BE 6 FEET. JOINT SPACINGS MAY BE MADE SLIGHTLY LONGER OR SHORTER AS APPROVED BY THE ENGINEER. LONGITUDINAL SAW CUT LINES SHALL BE LOCATED AT LANE DIVIDER LINES AND LANE CENTERLINES. ALL SAWED TWT PANELS SHALL BE SQUARE EXCEPT AS NECESSARY IN PAVEMENT WIDTH TRANSITIONS.
5. THE SAW CUT DEPTH SHALL BE MINIMUM OF ONE THIRD THE SLAB THICKNESS. THE SAW CUT DEPTH MUST BE ADJUSTED TO ACCOUNT FOR THICKENED PANELS.
6. MATCH TRANSVERSE JOINTS ON ADJOINING LANES. WHEN POSSIBLE, MATCH CURB-GUTTER JOINTS TO TRANSVERSE JOINTS.
7. LONGITUDINAL EXPANSION JOINTS MAY BE PROVIDED IF THE PAVEMENT IS WIDE ENOUGH TO CAUSE EXPANSIONS AND BLOWUPS.

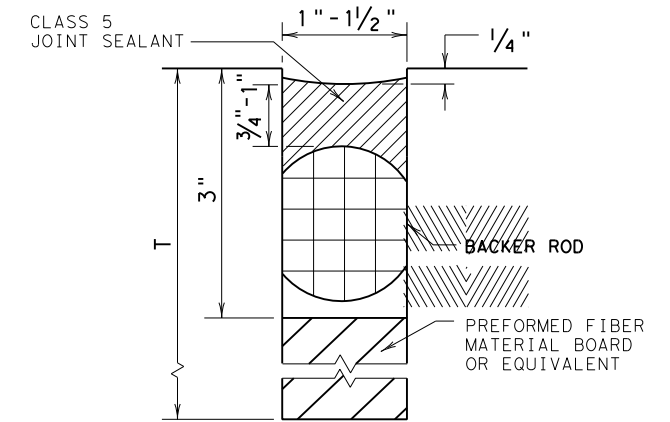
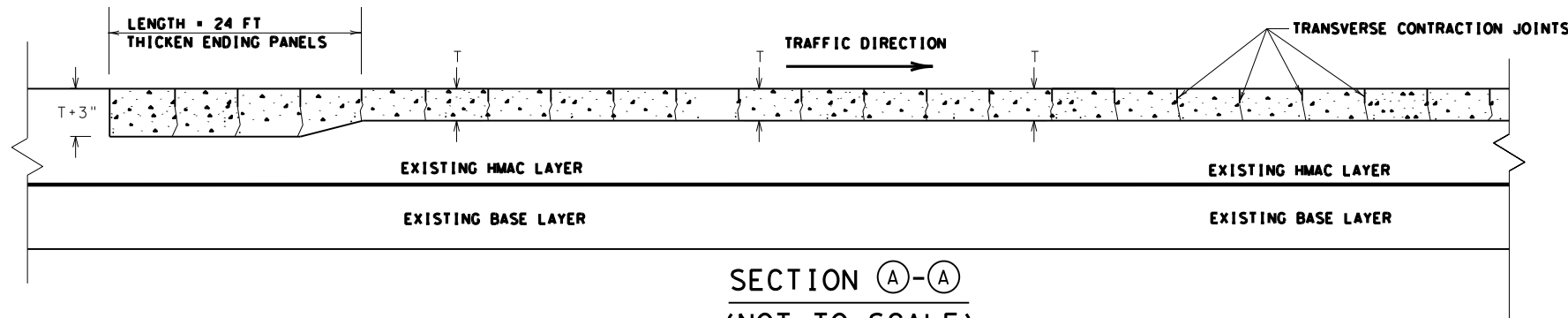

OPTIONAL LONGITUDINAL EXPANSION JOINTS

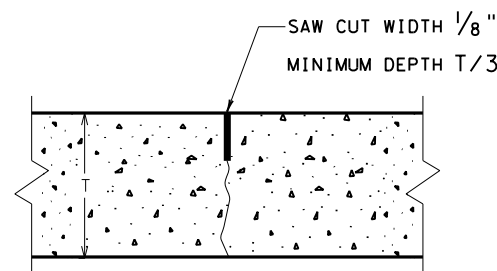

LONGITUDINAL AND TRANSVERSE CONTRACTION JOINTS DETAIL

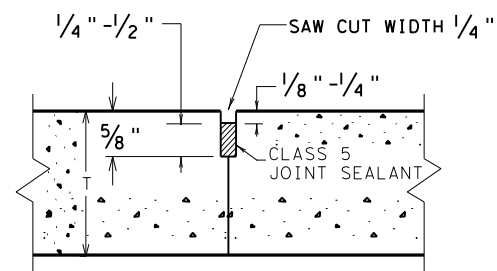

LONGITUDINAL AND TRANSVERSE CONSTRUCTION JOINTS DETAIL

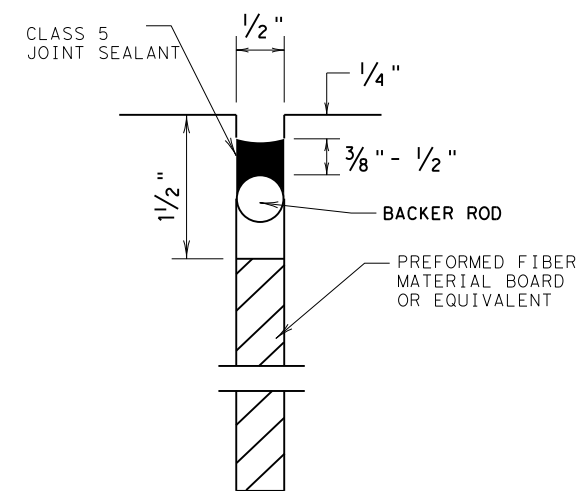

ISOLATION JOINTS

Isolation joints accommodate horizontal and vertical movements that occur between a pavement and a structure. Isolation joints may be used for bridge abutments, intersections, curb and gutter, between old and new pavements, or around drainage inlets, manholes, footings, and lighting structures.

		Design Division Standard							
THIN WHITETOPPING DETAILS T- 4 TO 7 INCHES TWT-04									
FILE:	twt04.dgn	DN:	TxDOT	CK:	MCW	DW:	HC	CK:	
© TxDOT	July 2004	CONT	SECT	JOB	HIGHWAY				
REVISIONS		DIST	COUNTY		SHEET NO.				