

DISCLAIMER: The use of this standard is governed by the "Texas Engineering Practice Act". No warranty of any kind is made by TxDOT for any purpose whatsoever. TxDOT assumes no responsibility for the conversion of this standard to other formats or for incorrect results or damages resulting from its use.

DATE: FILE:

General Notes:

1. Grounding System:
 - A. Description:
 1. Provide ground system consisting of copper wires, ground rods, and concrete-encased grounding electrodes (Ufers), of the configuration shown to minimize potential gradient irregularities, drain leakage, and fault currents to earth.
 - B. Performance:
 1. Provide a grounding system, consisting of a minimum one ground rod, having a resistance not greater than 5 Ohms to ground. Provide up to 2 additional supplemental ground rods if necessary to achieve a resistance not greater than 5 Ohms to ground. If a total of 3 ground rods is needed then install as as part of a ground ring.
 2. If a ground ring is required, provide a minimum conductor length of 20 ft. placed at a minimum depth of 30 in..
 - C. Design Criteria:
 1. The grounding system of the ITS pole may be bonded below grade to the grounding systems of other nearby equipment to meet the specified grounding resistance. A minimum of one ground rod for the ITS pole is still required.
 2. Separately measure the grounding resistance of each system before bonding together below grade.
 3. Only provide UL-approved materials listed for grounding systems.
 4. Do not combine materials that can form an electrolytic couple that will accelerate corrosion in the presence of moisture, unless moisture is permanently excluded from the junction of such materials.
 5. Submit product data for the materials and products used to perform the work of this section.
 - D. Materials:
 1. Conductors:
 - a. Bare Ground Conductor:
 - 1) Provide prequalified copper conductors appearing on the Material Producers List according to Item 618.
 2. Ground Compression Connectors:
 - a. Provide molds, thermite packages, and other material for exothermic welding of grounding connections.
 - b. Provide listed compression connectors fully rated to carry 100% of the cable rating and that meet IEEE 837. Provide compression materials from a single manufacturer throughout the project.
 3. Ground Rods:
 - a. Provide copper-clad steel ground rods conforming to the requirements specified in DMS 11040.
 - 1) Diameter: 5/8 in.
 - 2) Length: 10 ft.
 2. Installation:
 - A. Install grounding components and systems in accordance with the requirements specified in IEEE 142.
 - B. System Grounding:
 1. Ground Rods:
 - a. Drive ground rods into the ground until the tops of the rods are a minimum of 18 in. below finished grade.
 - b. If multiple ground rods are needed to meet the minimum resistance of 5 Ohms, space ground rods as evenly as possible, at least 6 feet apart, so conductors will be connected below grade.
 2. Conductors:
 - a. Provide minimum No. 2/0 AWG ground wire for lightning protection from air terminal.
 - b. Provide minimum No. 4 AWG ground wire for system and equipment grounding.
 - c. Using suitable fasteners, securely attach exposed ground wires to structural supports at not more than 2 ft. intervals, where applicable.
 - d. Bends in ground wires greater than 45 degrees are unacceptable.
 3. Cable Connections:
 - a. Use exothermic-welded connections or listed compression connectors for conductor splices and connections between conductors and other components.
 3. Testing:
 - A. Resistance Test:
 1. Test Procedure:
 - a. The ground-resistance measurements of each ground Rod shall be taken.
 - 1) The resistance to ground shall be measured in accordance with the fall-of-potential method specified in IEEE 81 and IEEE 142.
 - 2) Ground-resistance measurements shall be made in normally dry weather, not less than 48 hours after rainfall, and with the ground under test isolated from other grounds.
 - b. Test reports shall be prepared that indicate the location of the ground rod, the grounding system, and the resistance and soil conditions at the time the test was performed.
 2. Acceptance Criteria:
 - a. The grounding system must have a resistance not greater than 5 Ohms.
 - b. Do not energize any part of the electrical distribution system prior to the resistance testing of that system's ground rods and grounding system, and submission of the test results for approval.
 3. Inspections:
 - a. Prepare and submit as-built record drawings of the grounding system as installed and test reports for approval.

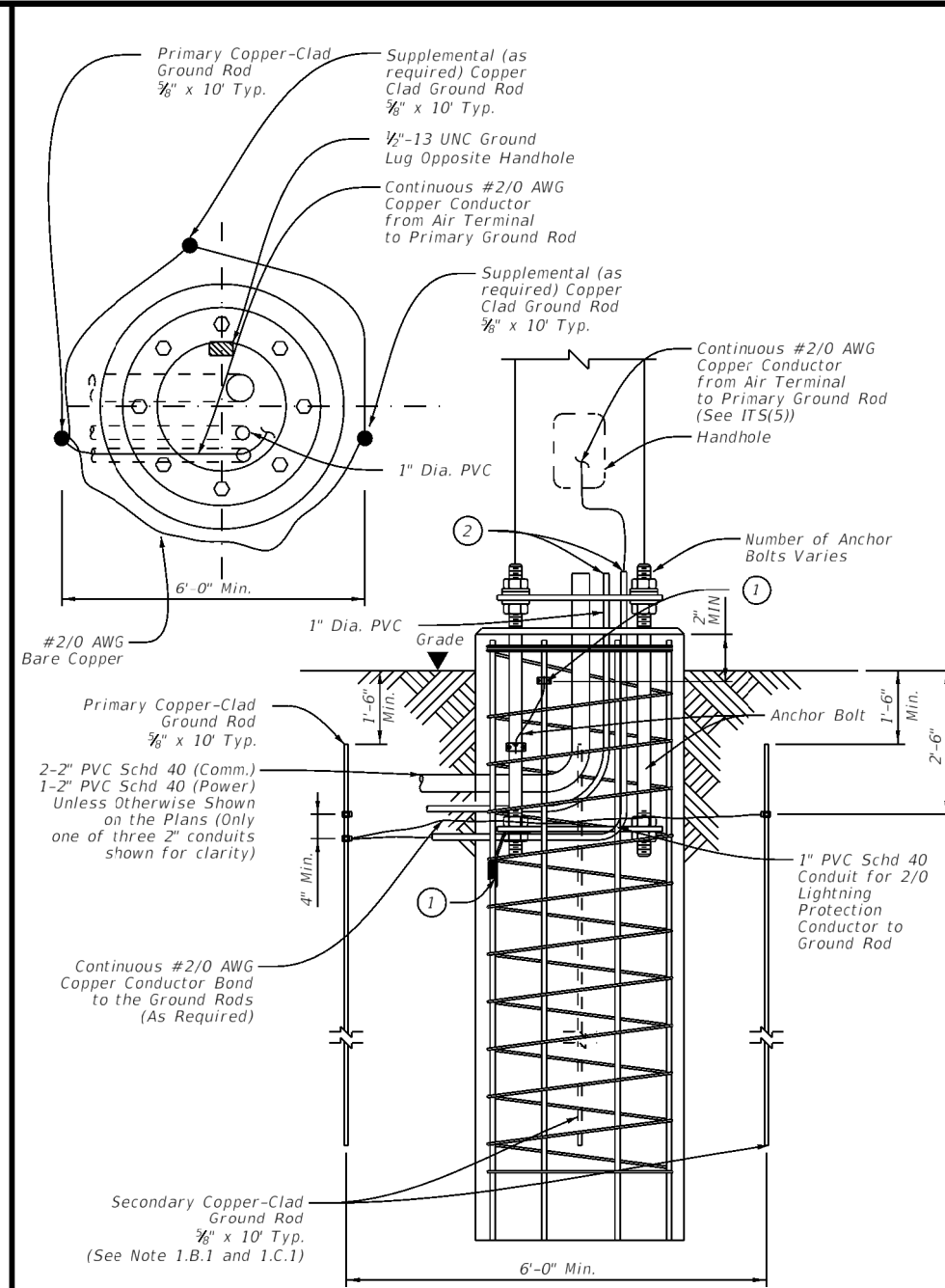

Grounding System
Not to Scale

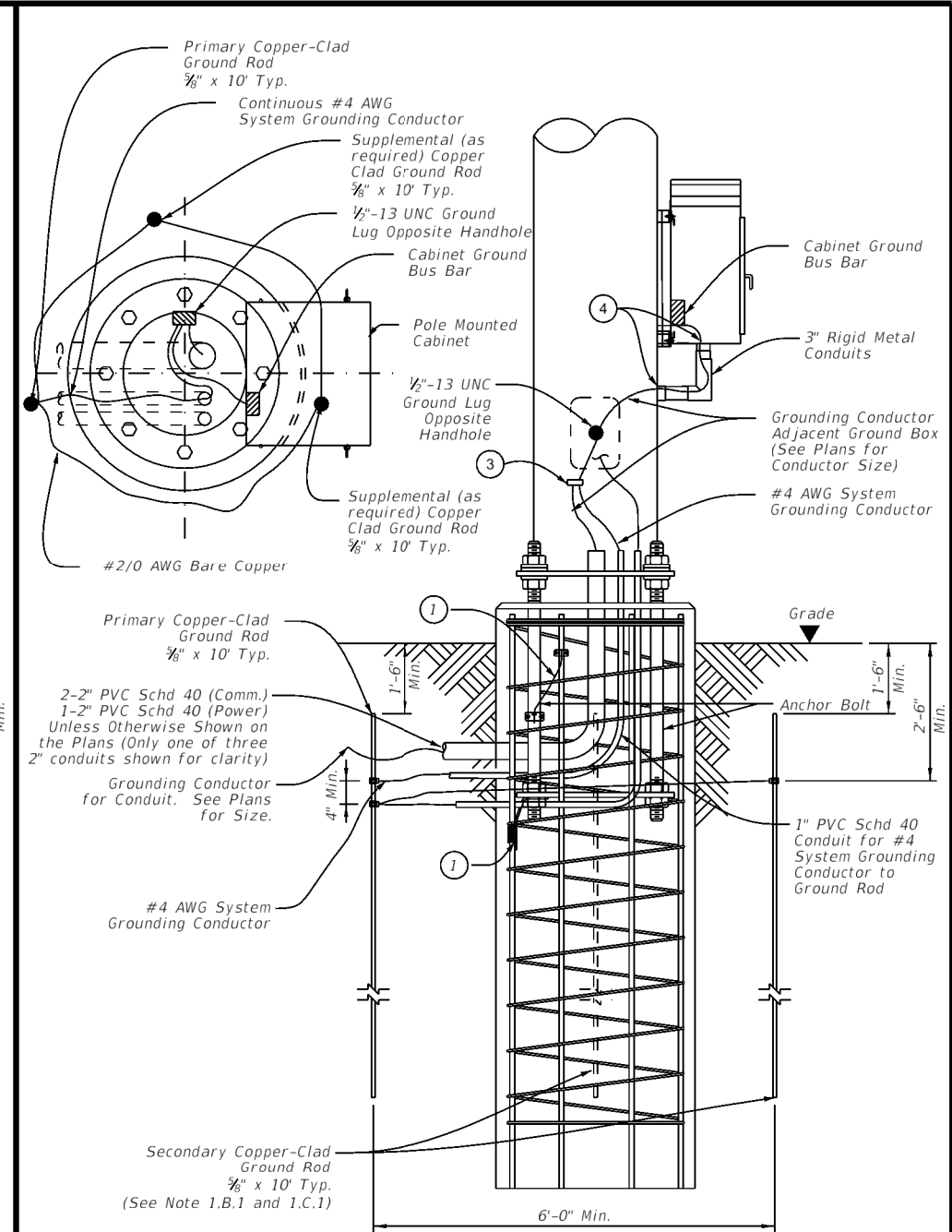

Grounding System with Pole Mounted Cabinet
Not to Scale

Reference Notes:

- ① Bond anchor bolts to rebar with #2/0 AWG jumper and two mechanical connectors or by bending No. 3 bar on bottom template as shown and wire tightly with ten turns of No. 10 wire or one mechanical connector. Mechanical connectors shall be UL Listed for concrete encasement.
- ② Cut PVC approximately 1 in. above concrete and install bell or bushing. Align conduit as close as possible to point of attachment to base plate to minimize bends in #2/0 wire.
- ③ Bond grounding conductors via cadweld or mechanical connector, rated for size and number of conductors.
- ④ Provide and install a grounding type bushing on metal conduit terminations. Install a bonding jumper from each grounding bushing to the nearest ground rod, grounding lug, or equipment grounding conductor. Ensure all bonding jumpers are the same size as the equipment grounding conductor.



ITS POLE GROUNDING DETAILS

ITS(19)-17

FILE: its(19)-17.dgn	DN: TxDOT	CK: TxDOT	DW: TxDOT	CR: TxDOT
© TxDOT June 2015	CONT	SECT	JOB	HIGHWAY
7-17	REVISIONS		DIST	COUNTY
			SHEET NO.	244