

DISCLAIMER: The use of this standard is governed by the "Texas Engineering Practice Act". No warranty of any kind is made by TxDOT for any purpose whatsoever. TxDOT assumes no responsibility for damages resulting from its use.

DATE: FILE:

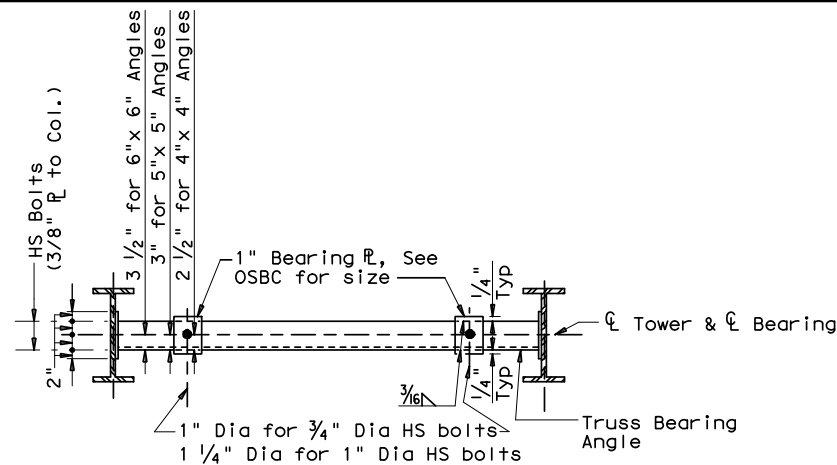

PLAN AT TRUSS BEARING ANGLE

COLUMN SPA. "S"	TRUSS BEARING ANGLE	HS BOLTS (DIA)
6'-0"	L 4 x 4 x 5/16	5/8"
6'-6"	L 5 x 5 x 3/8	5/8"
7'-0"	L 5 x 5 x 1/2	3/4"
7'-6" to 8'-6"	L 6 x 6 x 5/8	3/4"
9'-0"	L 6 x 6 x 3/4	3/4"
9'-6"	L 6 x 6 x 7/8	3/4"

② Nominal Dia. x 1 1/2" slots in plate. (Top only) Use washer on plate side of HS bolt. (See table above for size of bolts.)

GENERAL NOTES:

Design conforms to 1994 AASHTO Standard Specifications for Structural Supports for Highway Signs, Luminaires and Traffic Signals and Interim revisions thereto for design heights up to 50 feet.  
 For size and spacing of columns see sheets, "Overhead Sign Bridge Details."  
 At contractor's option tower bracing connections may be high strength (HS) bolted or welded. If welded connections are used, length of connection shall be taken from the table shown on sheet, "Overhead Sign Bridge Truss Details-OSBC."  
 All connection bolts shall conform to ASTM A325 Type 1. Washers shall conform to ASTM F436. Bolts, nuts and washers shall be galvanized per Item 445, "Galvanizing".  
 All structural steel shall conform to ASTM A36 except where noted. Structural steel shall be galvanized after fabrication per Item 445, "Galvanizing".  
 Anchor bolts and nuts for anchor bolts shall be "Alloy steel" per Item 449, "Anchor Bolts".  
 Anchor bolts shall be rigidly held in position during concrete placement by using steel templates at the top and bottom. The bottom template and anchor plate assembly shall remain in place and shall not be damaged during concrete placement. The top template shall be removed after concrete has set.  
 Exposed nuts and washers shall be galvanized in accordance with Item 449, "Galvanizing". Embedded nuts and top and bottom templates need not be galvanized.  
 Lubricate and tighten the anchor bolts when erecting the structure per Item 449, "Anchor Bolts". After the structure has been aligned in its final position and the anchor bolts have been properly tightened, tack weld anchor bolt nuts to washers, and tack weld washers to base plates. Galvanizing in tack welded areas shall be repaired per Item 445, "Galvanizing".  
 Concrete shall be Class "C".

SPECIAL NOTE FOR TOWER BRACING

Normally, the maximum spacing for tower bracing is the same as column spacing; However, this spacing may be increased as follows:  
 Determine required column size and spacing to satisfy height for the wind zone and truss span being used.  $Height = (H_L + H_R) / 2$ .  
 Note the number of times this column size is shown for larger heights for the same span and wind zone.  
 Spacing of bracing may be increased 1'-0" for each time height is shown, except the increase shall not exceed 5'-0".

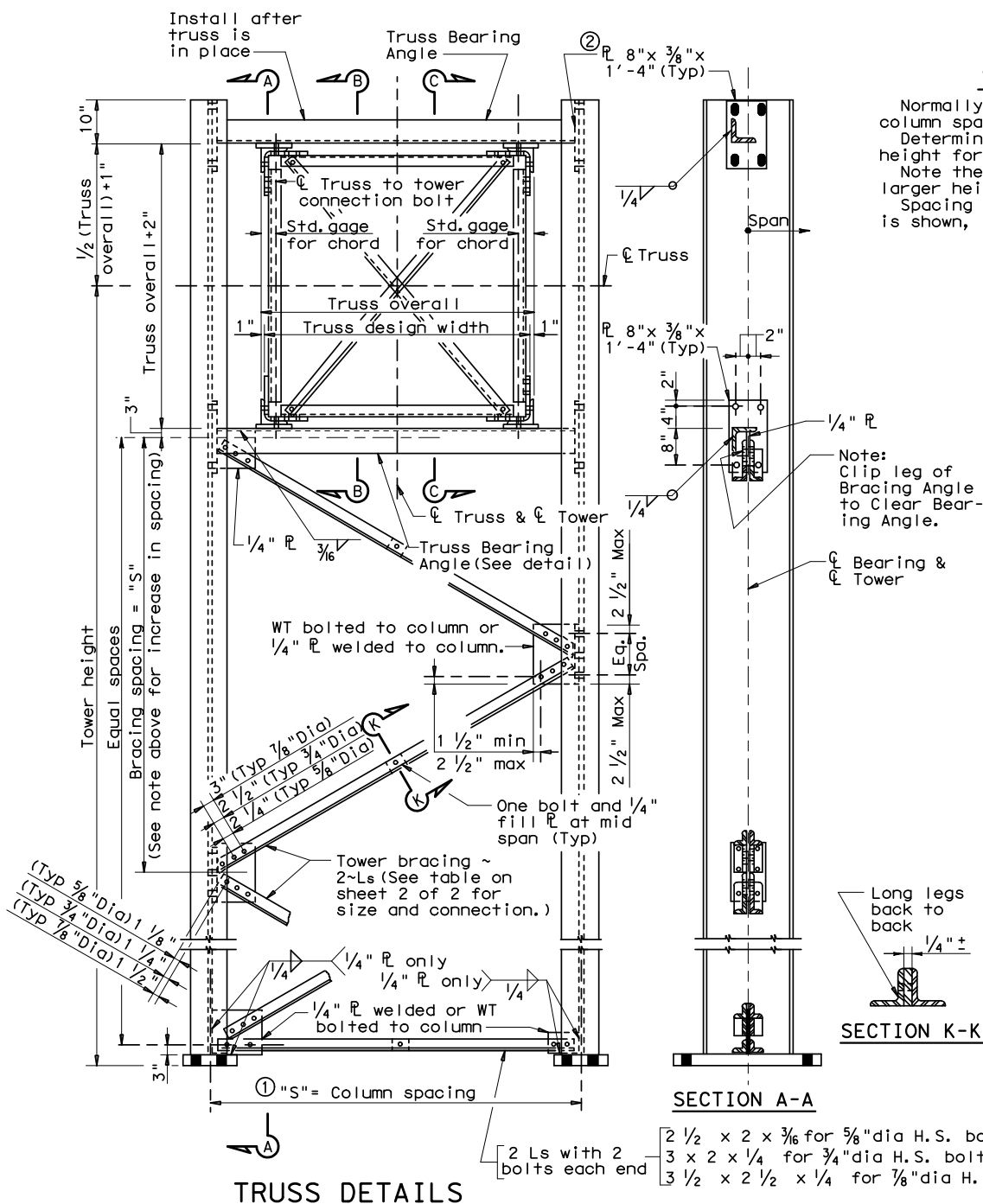

TRUSS DETAILS

① For column spacing see standard drawing, "Overhead Sign Bridge Details"

[ 2 Ls with 2 bolts each end ]  
 2 1/2 x 2 x 3/16 for 5/8" dia H.S. bolts.  
 3 x 2 x 1/4 for 3/4" dia H.S. bolts.  
 3 1/2 x 2 1/2 x 1/4 for 7/8" dia H.S. bolts.

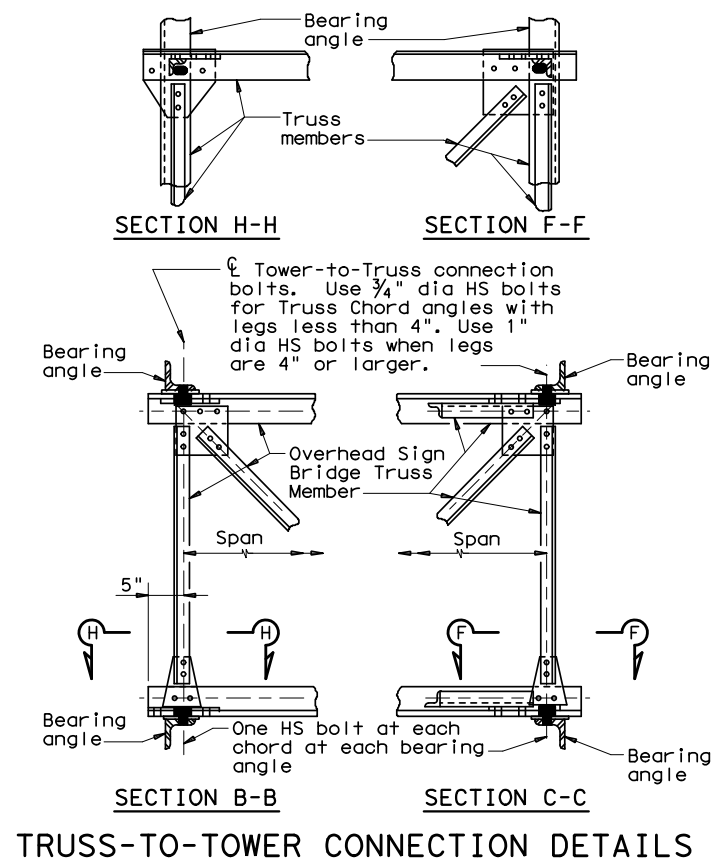

TRUSS-TO-TOWER CONNECTION DETAILS

SHEET 1 OF 2

Texas Department of Transportation  
 Traffic Operations Division

OVERHEAD SIGN BRIDGE  
 TOWER DETAILS

OSBT

© TxDOT November 2007		REV: TxDOT	CK: TxDOT	DN: TxDOT	CK: TxDOT
REV	DATE	BY	CHKD	APPV	REASON

DISCLAIMER: The use of this standard is governed by the "Texas Engineering Practice Act". No warranty of any kind is made by TxDOT for any purpose whatsoever. TxDOT assumes no responsibility for the conversion of this standard to other formats or for incorrect results or damages resulting from its use.

DATE: FILE:

BRACING FOR 9'-0" TO 9'-6" COLUMN SPACING					BRACING FOR 8'-0" TO 8'-6" COLUMN SPACING					BRACING FOR 7'-0" TO 7'-6" COLUMN SPACING					BRACING FOR 6'-0" TO 6'-6" COLUMN SPACING					"X"	"Y"	"Z"	BASE PLATE SIZE L x W x T	ANCHOR BOLT SIZE DIA. x LENGTH	FOUNDATION DATA DIA. DRILL SHAFT/W REINF.	COLUMN SIZE					
SIZE DOUBLE ANGLES		BOLTS REQUIRED			SIZE DOUBLE ANGLES		BOLTS REQUIRED			SIZE DOUBLE ANGLES		BOLTS REQUIRED			SIZE DOUBLE ANGLES		BOLTS REQUIRED														
		BRACING	WT to W				BRACING	WT to W				BRACING	WT to W				BRACING	WT to W													
3/4"	7/8"	3/4"	7/8"		3/4"	7/8"	3/4"	7/8"		5/8"	3/4"	7/8"	5/8"	3/4"	7/8"	5/8"	3/4"	7/8"	5/8"	3/4"	7/8"										
2 Ls 4 x 4 x 5/16		6	4	10	8																	15 1/4"	5"	4"	18"x 3 1/4"x 3'-4 1/2"	2 3/4"x 5'-8"	48" Dr Shaft with 18~#11	W24 x 117			
2 Ls 4 x 4 x 5/16		6	4	10	8	2 Ls 4 x 3 x 5/16		5	4	10	8	2 Ls 4 x 3 x 5/16		7	5	4	12	10	8						15 1/4"	5"	4"	18"x 3 1/8"x 3'-4 1/2"	2 3/4"x 5'-8"	48" Dr Shaft with 18~#11	W24 x 104
2 Ls 4 x 4 x 5/16		6	4	10	8	2 Ls 4 x 3 x 5/16		5	4	10	8	2 Ls 4 x 3 x 5/16		7	5	4	12	10	8						15 1/4"	5"	4"	18"x 3"x 3'-4 1/2"	2 3/4"x 5'-8"	48" Dr Shaft with 18~#11	W24 x 94
2 Ls 4 x 4 x 5/16		6	4	10	8	2 Ls 4 x 3 x 5/16		5	4	10	8	2 Ls 3 1/2 x 3 x 5/16		6	5	4	12	8	6						15"	4 1/2"	3 3/4"	16 1/2"x 3"x 3'-3"	2 1/2"x 5'-2"	48" Dr Shaft with 14~#11	W24 x 84
2 Ls 4 x 3 1/2 x 5/16		5	4	10	8	2 Ls 4 x 3 x 5/16		5	4	10	8	2 Ls 3 1/2 x 3 x 1/4		6	4	3	10	8	6						14 3/4"	4 1/2"	3 3/4"	16 1/2"x 2 3/4"x 3'-2 1/2"	2 1/2"x 5'-2"	48" Dr Shaft with 14~#11	W24 x 76
2 Ls 4 x 3 1/2 x 5/16		5	4	10	8	2 Ls 3 1/2 x 3 x 5/16		5	4	8	6	2 Ls 3 1/2 x 3 x 1/4		6	4	3	10	8	6						14 3/4"	4 1/2"	3 3/4"	16 1/2"x 2 3/4"x 3'-2 1/2"	2 1/2"x 5'-2"	48" Dr Shaft with 14~#11	W24 x 68
2 Ls 4 x 3 1/2 x 5/16		5	4	10	8	2 Ls 3 1/2 x 3 x 5/16		5	4	8	6	2 Ls 3 1/2 x 3 x 1/4		6	4	3	10	8	6						13 1/2"	4 1/2"	3 3/4"	16 1/2"x 2 3/4"x 3'-0"	2 1/2"x 5'-2"	42" Dr Shaft with 12~#11	W21 x 68
2 Ls 4 x 3 x 5/16		5	4	10	8	2 Ls 3 1/2 x 3 x 5/16		5	4	8	6	2 Ls 3 1/2 x 3 x 1/4		6	4	3	10	8	6						13 1/2"	4 1/2"	3 3/4"	16 1/2"x 2 1/2"x 3'-0"	2 1/2"x 5'-2"	42" Dr Shaft with 12~#11	W21 x 62
2 Ls 4 x 3 x 5/16		5	4	10	8	2 Ls 3 1/2 x 3 x 5/16		5	4	8	6	2 Ls 3 1/2 x 3 x 1/4		6	4	3	10	8	6						13"	4"	3 1/2"	15"x 2 1/2"x 2'-10"	2 1/4"x 4'-9"	42" Dr Shaft with 10~#11	W21 x 57
2 Ls 4 x 3 x 5/16		5	4	10	8	2 Ls 4 x 3 x 1/4		4	3	8	6	2 Ls 3 1/2 x 3 x 1/4		5	4	3	10	6	4						11 3/4"	4"	3 1/2"	15"x 2 1/2"x 2'-7 1/2"	2 1/4"x 4'-9"	42" Dr Shaft with 10~#11	W18 x 55
2 Ls 4 x 3 x 5/16		5	4	10	8	2 Ls 4 x 3 x 1/4		4	3	8	6	2 Ls 3 1/2 x 2 1/2 x 1/4		5	4	3	8	6	4						11 3/4"	4"	3 1/2"	15"x 2 1/2"x 2'-7 1/2"	2 1/4"x 4'-9"	42" Dr Shaft with 10~#11	W18 x 50
2 Ls 4 x 3 x 5/16		5	4	10	8	2 Ls 4 x 3 x 1/4		4	3	8	6	2 Ls 3 1/2 x 2 1/2 x 1/4		4	3	~	8	6	4						11 1/2"	3 1/2"	3"	13"x 2 1/2"x 2'-6"	2"x 4'-3"	42" Dr Shaft with 8~#10	W18 x 46
2 Ls 4 x 3 x 5/16		5	4	10	8	2 Ls 4 x 3 x 1/4		4	3	8	6	2 Ls 3 x 2 1/2 x 1/4		4	3	~	8	6	4						10 1/2"	3 1/2"	3"	13"x 2 1/4"x 2'-4"	2"x 4'-3"	36" Dr Shaft with 8~#10	W16 x 40
2 Ls 4 x 3 x 5/16		5	4	10	8	2 Ls 3 1/2 x 3 x 1/4		4	3	8	6	2 Ls 3 x 2 1/2 x 1/4		4	3	~	8	6	4						10 1/4"	3"	2 3/4"	11 1/2"x 2 1/4"x 2'-2 1/2"	1 3/4"x 3'-10"	36" Dr Shaft with 8~#9	W16 x 36
2 Ls 4 x 3 x 5/16		5	4	10	8	2 Ls 3 1/2 x 3 x 1/4		4	3	8	6	2 Ls 3 x 2 1/2 x 1/4		3	2	~	6	4	4						9 1/2"	3"	2 3/4"	11 1/2"x 2 1/4"x 2'-1"	1 3/4"x 3'-10"	36" Dr Shaft with 8~#9	W14 x 34
2 Ls 4 x 3 x 5/16		5	4	10	8	2 Ls 4 x 3 x 1/4		4	3	8	6	2 Ls 3 x 2 1/2 x 1/4		3	~	4	4	4						9 1/4"	3"	2 3/4"	11 1/2"x 2"x 2'-0 1/2"	1 3/4"x 3'-10"	36" Dr Shaft with 8~#9	W14 x 30	
2 Ls 4 x 3 x 5/16		5	4	10	8	2 Ls 4 x 3 x 1/4		4	3	8	6	2 Ls 3 x 3 x 3/16		2	2	~	4	4	4						8"	2 3/4"	2 1/8"	9 3/4"x 1 3/4"x 1'-9 1/2"	1 1/2"x 3'-4"	30" Dr Shaft with 8~#8	W12 x 26
2 Ls 4 x 3 x 5/16		5	4	10	8	2 Ls 4 x 3 x 1/4		4	3	8	6	2 Ls 2 1/2 x 2 1/2 x 3/16		2	~	4	4	4						7"	2 1/2"	2"	9"x 1 3/4"x 1'-7"	1 3/8"x 3'-1"	30" Dr Shaft with 8~#8	W10 x 26	
2 Ls 4 x 3 x 5/16		5	4	10	8	2 Ls 4 x 3 x 1/4		4	3	8	6	2 Ls 2 1/2 x 2 x 3/16		2	~	4	4	4						6 3/4"	2 1/4"	1 5/8"	8 1/4"x 1 1/2"x 1'-6"	1 1/4"x 2'-11"	30" Dr Shaft with 8~#8	W10 x 22	
2 Ls 4 x 3 x 5/16		5	4	10	8	2 Ls 4 x 3 x 1/4		4	3	8	6	2 Ls 2 1/2 x 2 x 3/16		2	~	4	4	4						6 3/4"	2"	1 5/8"	7 1/4"x 1 3/8"x 1'-5 1/2"	1 1/8"x 2'-8"	24" Dr Shaft with 8~#7	W10 x 17	
2 Ls 4 x 3 x 5/16		5	4	10	8	2 Ls 4 x 3 x 1/4		4	3	8	6	2 Ls 2 1/2 x 2 x 3/16		2	~	4	4	4						6 1/2"	1 3/4"	1 1/2"	6 1/2"x 1 1/4"x 1'-4 1/2"	1"x 2'-5"	24" Dr Shaft with 8~#7	W10 x 15	

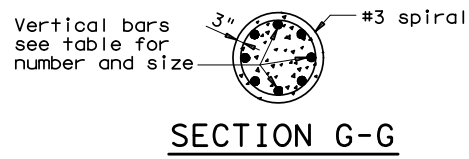
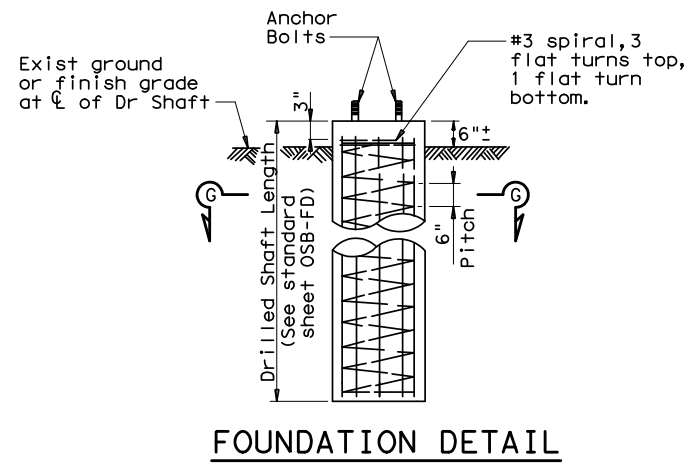
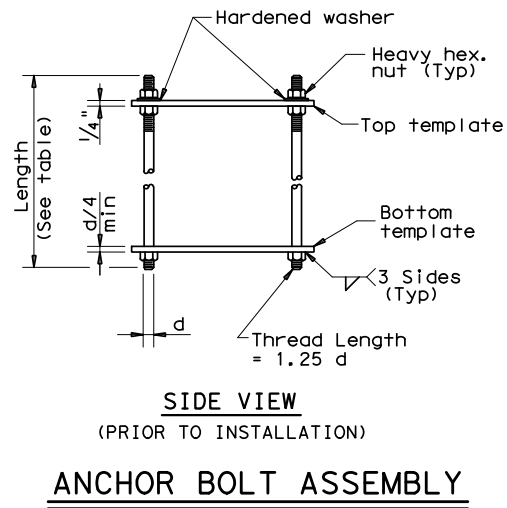
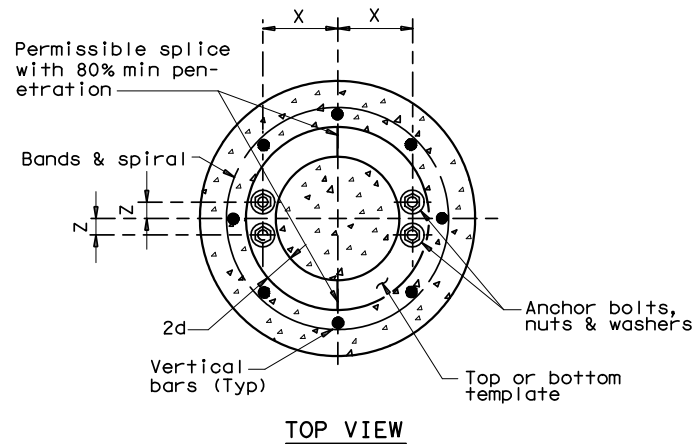

Anchor Bolt Dia. (d)	Washer Dimensions			Hole in Base Plate	
	Outside Diameter	Hole Diameter	Thickness		
			Min		Max
1/2" or less	2d	d + 1/8"	0.136"	0.177"	d + 1/4"
1 3/4"	2d - 1/8"	d + 1/8"	0.178"	0.280"	d + 5/16"
2"	2d - 1/4"	d + 1/8"	0.178"	0.280"	d + 5/16"
over 2"	2d - 1/2"	d + 1/8"	0.240"	0.340"	d + 5/16"

ANCHOR BOLT SIZE				
DIA	BOLT LENGTH	THREAD LENGTH	PROJECTION LENGTH	GALVAN. LENGTH
1"	2'-5"	4"	4 1/2"	10"
1 1/8"	2'-8"	4 1/2"	5"	10 1/2"
1 1/4"	2'-11"	5"	5 1/2"	11"
1 3/8"	3'-1"	5 1/2"	6"	11 1/2"
1 1/2"	3'-4"	6"	6 1/2"	1'-0"
1 3/4"	3'-10"	7"	7 1/2"	1'-1"
2"	4'-3"	8"	8 1/2"	1'-2"
2 1/4"	4'-9"	9"	9 1/2"	1'-3"
2 1/2"	5'-2"	10"	10 1/2"	1'-4"
2 3/4"	5'-8"	11"	11 1/2"	1'-5"

Anchor Bolt Fabrication Tolerances:  
 Bolt Length ~ ±1/2"  
 Thread Length ~ ±1/2"  
 Galvanized Length ~ -1/4"

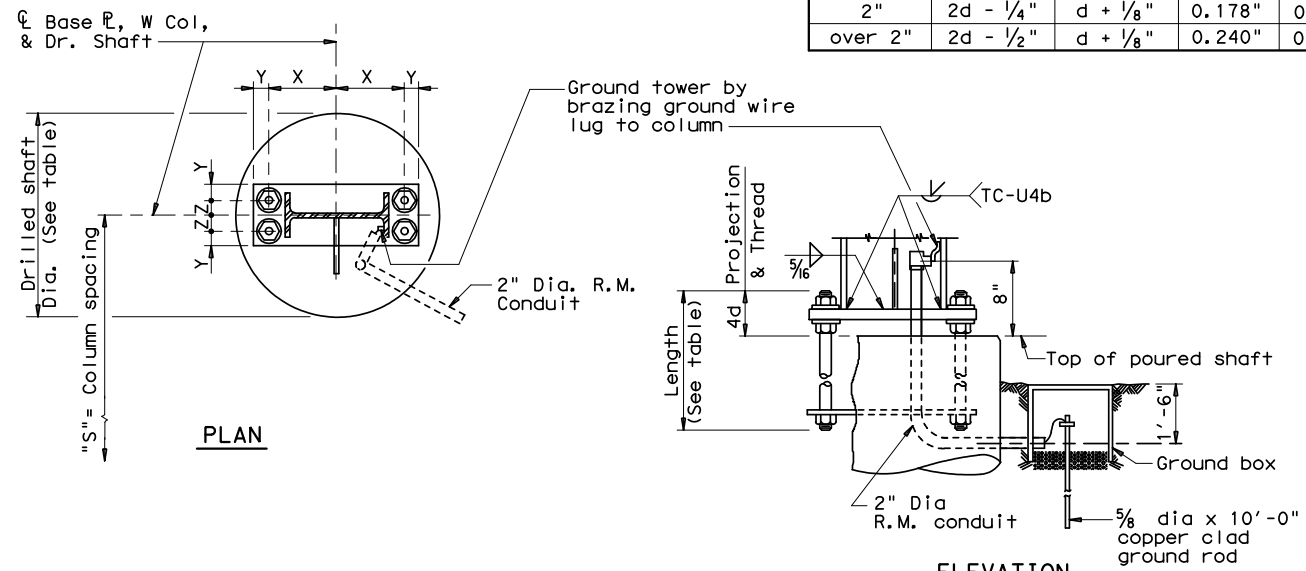

BEARING SEAT DETAILS  
 (See table for base plate size anchor bolt size, dimensions X, Y, Z and drilled shaft diameter.)

SHEET 2 OF 2

Texas Department of Transportation  
 Traffic Operations Division

# OVERHEAD SIGN BRIDGE TOWER DETAILS

OSBT

© TxDOT November 2007	REV: TxDOT	CK: TxDOT	HW: TxDOT	CK: TxDOT
REVISIONS	CUA/T	SECT	JUP	HIGHWAY
DIST	COUNTY	SHEET NO.		