Test Procedure for**SHEAR BOND STRENGTH TEST****TxDOT Designation: Tex-249-F****Effective Date: 11/17-06/19**

1. SCOPE

- 1.1 This test determines the shear strength between two bonded pavement layers. Specimens are most often cores from the field, but bonded laboratory specimens may also be tested.
- 1.2 Measurements on three specimens constitute a single test.
- 1.3 The values given in parentheses (if provided) are not standard and may not be exact mathematical conversions. Use each system of units separately. Combining values from the two systems may result in nonconformance with the standard.
-

2. APPARATUS

- 2.1 *Measuring device*, such as a ruler or calipers.
- 2.2 *Interlayer Shear Strength Device*, capable of holding the test specimen horizontally and consisting of two parts:
- a fixed sleeve to hold one side of the specimen and to provide a reaction force; and
 - a sliding sleeve holding the other side of the specimen that moves perpendicular to the specimen's vertical axis and produces the shear load. While testing, the sliding sleeve must only move vertically.
- 2.2.1 The device must accommodate 6-in. diameter cores.
- 2.2.2 Core shims are required when testing cores that are more than 1/8 in. smaller than the target diameter. Shim thicknesses may range from 1/16 to 1/2 in. thick.
- 2.2.3 The gap between the sliding and reaction sleeves should be 1/4 in., and optionally adjust to accommodate larger gaps.
-

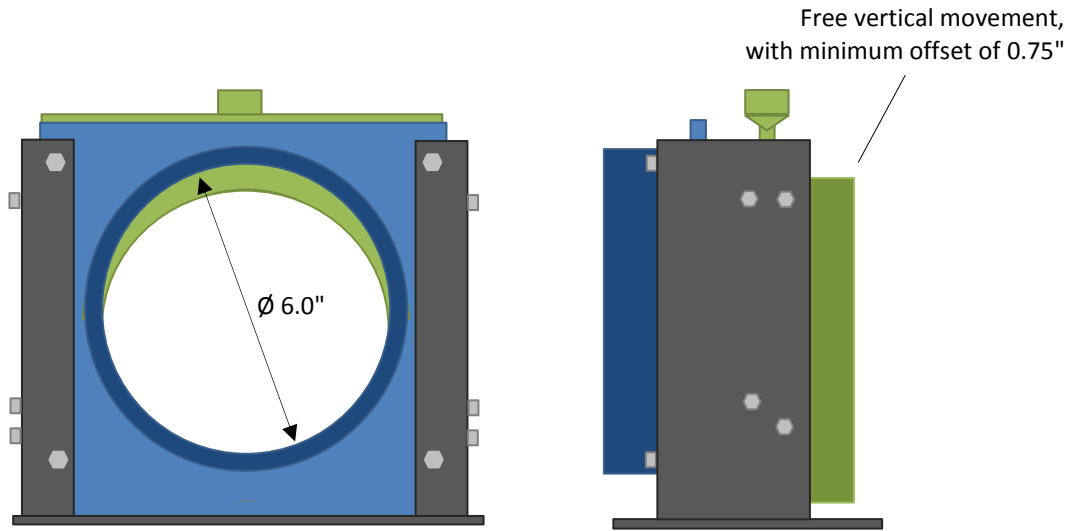
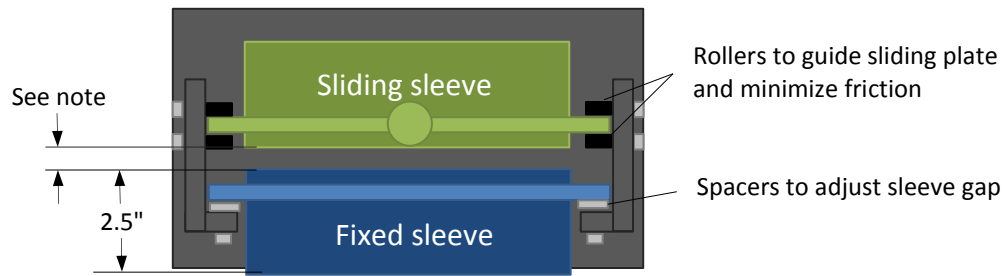

Figure 1—Interlayer Shear Strength Device (Side View)



Note: Dimension can be adjusted to 1/4, 3/8, 1/2, and 3/4 in.

Figure 2—Interlayer Shear Strength Device (Top View)

2.3 *Loading Frame*, capable of applying a compressive load at a controlled deformation rate of 0.2 ± 0.02 in. per min. The load cell should have a working range of 200–5,000 lb. with an accuracy of 1%. A higher working range—up to 10,000 lb.—may be needed for unique scenarios.

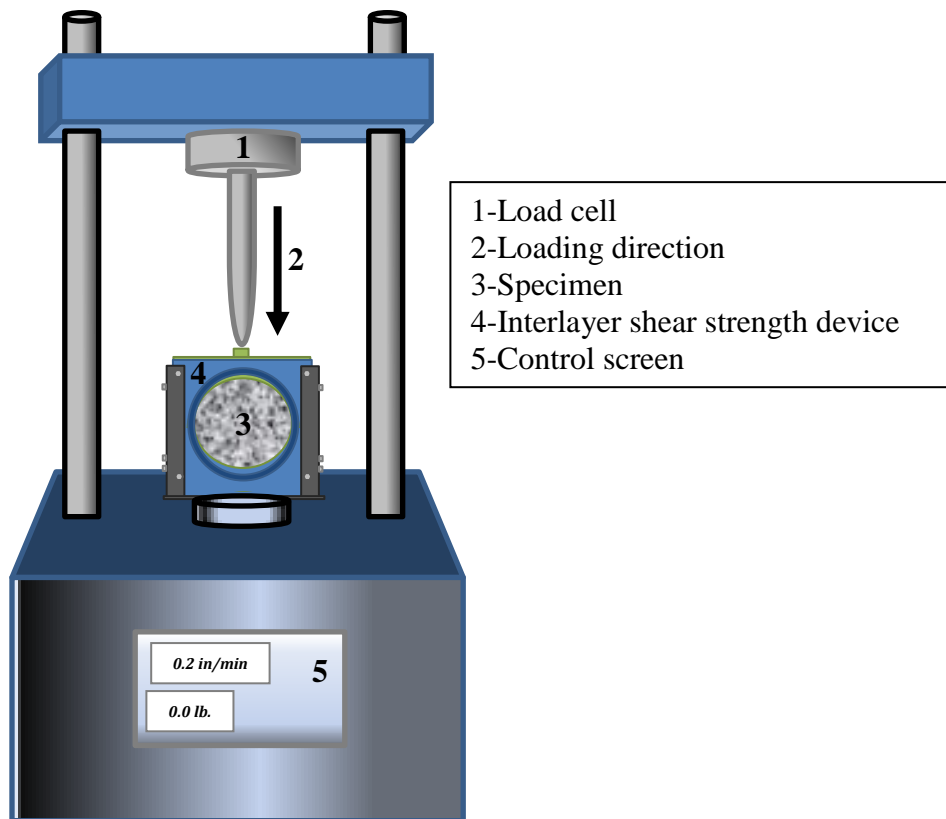

Figure 3—Loading Frame with Shear Strength Device

2.4 *Core Drill and Core Barrel.*

2.5 *Temperature Chamber or Heating Oven, capable of maintaining $77 \pm 1^\circ\text{F}$.*

3. PROCEDURE

3.1 *Preparing Specimens:*

3.1.1 Obtain three roadway cores with a diameter of 5.5–6.0 in. Obtain cores within 3 days of paving when testing for specification compliance (new overlay construction).

Note 1— There is no specific density requirement.

3.1.2 Mark the direction of traffic on the surface prior to coring.

3.1.3 Core the surface layer and at least 1.5 in. below the bonded interface. Remove the cores carefully to minimize stress to the bond and surrounding layers.

Note 2—Make a note if any core de-bonds at the interface in question during sampling. Save sample for visual inspection and report shear strength of 0 psi.

3.1.4 Trim cores so that the thickness between the bond and either specimen end is no more than 3.0 in.

- 3.1.5 Oven-dry the specimens at $100 \pm 5^\circ\text{F}$ to constant weight. Do not leave the specimens in the oven for more than 24 hr.
- Note 3**—“Constant weight” is the weight at which further oven drying does not alter the weight by more than 0.05% in a 2-hr. or longer drying interval when calculated in accordance with Section 4.1.
- 3.2 *Testing Specimens:*
- 3.2.1 For each specimen, measure the diameter at four different locations to the nearest 1/16 in. and calculate the average of the readings.
- 3.2.2 Place the specimens in a chamber or an oven at $77 \pm 2^\circ\text{F}$ for a minimum of 2 hr. before testing.
- 3.2.3 Slide a specimen into the shearing apparatus and position the bonded interface in question in the center of the gap. Orient the specimen so the traffic direction is vertical. As needed, insert core shims to limit free movement.
- Note 4**—Clearly mark the bond before placing the specimen in the apparatus to aid in locating the bond. Ensure that core shims do not interfere with the shearing gap.
- 3.2.4 Position the apparatus in the loading frame, apply the shearing load at a constant rate of displacement of 0.2 in. per min., and stop after the maximum load is achieved and the load has decreased substantially.
- Note 5**—Ensure the sliding half of the shear apparatus does not bottom-out during testing. This will damage the equipment.

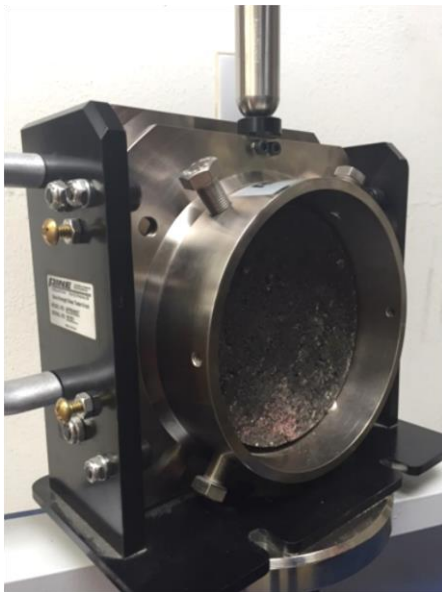

Figure 4—Loading Frame in Bottom-Out Position

- 3.2.5 Record the maximum load.
- 3.2.6 Note the location of the failure (at the bond interface or in the adjacent layers).

3.2.7 Repeat Sections 3.2.3–3.2.6 for the second and third specimens.

4. CALCULATIONS

4.1 Calculate the percent difference in weight:

$$\text{Percent Difference} = \left(\frac{\text{InitialWeight} - \text{FinalWeight}}{\text{InitialWeight}} \right) * 100$$

4.2 Calculate the maximum shear strength of each specimen:

$$\text{Shear}_{max} = 4 * F_{Max} / (\pi D^2)$$

Where:

Shear_{max} = Maximum shear strength, psi

F_{Max} = Maximum load, lb.

D = Average specimen diameter, in.

5. REPORT

5.1 Report the following:

- maximum shear strength and location of failure of individual specimens,
- average shear strength of the three specimens, and
- additional comments.

5.2 Report the average shear strength of the tested cores to the nearest tenth.