

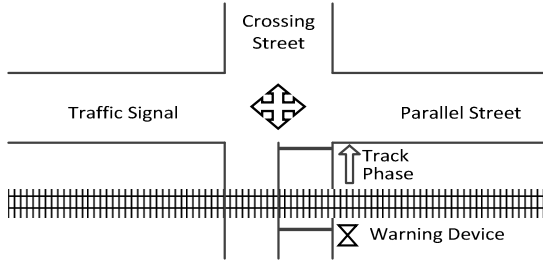

Texas Department of Transportation
GUIDE FOR DETERMINING TIME REQUIREMENTS FOR
TRAFFIC SIGNAL PREEMPTION AT HIGHWAY-RAIL GRADE CROSSINGS

Form 2304
(Rev. 7/19)

City _____ CSJ _____ Date _____
 County _____ Completed by _____
 District _____ District Approval _____

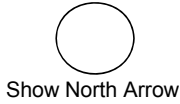

Parallel Street Name _____
 Crossing Street Name _____

Railroad _____ Railroad Contact _____
 Crossing DOT# _____ Phone _____

NOTE: After approval by the District, a copy of this form, along with the traffic signal design sheets and the phasing diagrams for normal and preempted operation, shall be placed in the traffic signal cabinet. See Section 7 for traffic signal timings.

SECTION 1: GEOMETRY DATA & DEFAULTS

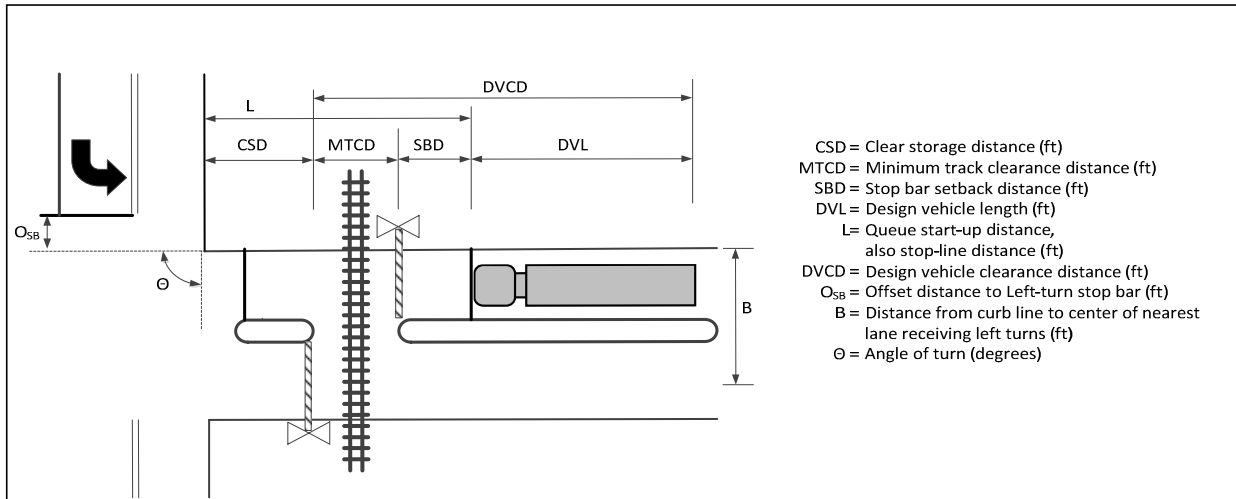

GEOMETRIC DATA FOR CROSSING

1. Clear storage distance (CSD, feet)	1.	<input style="width: 50px; height: 20px;" type="text"/>
2. Minimum track clearance distance (MTCD, feet)	2.	<input style="width: 50px; height: 20px;" type="text"/>
3. Stop bar setback distance (SBD, feet)	3.	<input style="width: 50px; height: 20px;" type="text"/>
4. Width of receiving approach (B, feet).....	4.	<input style="width: 50px; height: 20px;" type="text"/>
5. Offset distance of left turn stop bar (O _{SB} , feet).....	5.	<input style="width: 50px; height: 20px;" type="text"/>
6. Approach grade. % (0 if approach is on downgrade)	6.	<input style="width: 50px; height: 20px;" type="text"/>
7. Angle of turn at Intersection (θ, degrees).....	7.	<input style="width: 50px; height: 20px;" type="text"/>

Remarks

 Enter "0" if no stop bar is present

DESIGN VEHICLE DATA

8. Select Design Vehicle

School Bus	Intermediate Truck	Interstate Semi-Truck	Other
------------	--------------------	-----------------------	-------

9. Default design vehicle length (feet)	9.	<input style="width: 50px; height: 20px;" type="text"/>
a. Additional vehicle length, if needed (feet)	9a.	<input style="width: 50px; height: 20px;" type="text"/>
10. Total design vehicle length (DVL, feet)	10.	<input style="width: 50px; height: 20px;" type="text"/>
11. Centerline turning radius of design vehicle (R, feet).....	11.	<input style="width: 50px; height: 20px;" type="text"/>
12. Passenger car vehicle length (LV, feet).....	12.	<input style="width: 50px; height: 20px;" type="text"/>

Based on selected Design Vehicle
 Use only if "Other" selected as Design Vehicle
 Sum of line 9 and 9a
 Based on selected Design Vehicle
 Default value

SECTION 2: RIGHT-OF-WAY TRANSFER TIME CALCULATION

Preempt verification and response time

- 13. Preempt delay time (seconds) 13.
- 14. Controller response time to preempt (seconds) 14.

- 15. Preempt verification and response time (seconds): add lines 13 and 14 15.

Remarks

Manufacturer: _____
 Firmware Version: _____

Worst-case conflicting vehicle time

- 16. Minimum green time during right-of-way transfer (seconds) 16.
- 17. Other green time during right-of-way transfer (seconds) 17.
- 18. Yellow change time (seconds) 18.
- 19. Red clearance time (seconds) 19.

- 20. Worst-case conflicting vehicle time (seconds): add lines 16 through 19 20.

Remarks

Value may be adjusted to meet local conditions

Worst-case conflicting pedestrian time

- 21. Minimum walk time during right-of-way transfer (seconds) 21.
- 22. Pedestrian clearance time during right-of-way transfer (seconds) 22.
- 23. Vehicle yellow change time, if not included on line 22 (seconds) 23.
- 24. Vehicle red clearance time, if not included on line 22 (seconds) 24.

- 25. Worst-case conflicting pedestrian time (seconds): add lines 21 through 24 25.

Remarks

Value may be adjusted to meet local conditions
 Refer to instructions for pedestrian truncation guidance

Worst-case conflicting vehicle or conflicting pedestrian time

- 26. Worst-case conflicting vehicle or conflicting pedestrian time (seconds): maximum of lines 20 and 25 26.
- 27. Right-of-way transfer time (seconds): add lines 15 and 26 27.

SECTION 3: QUEUE CLEARANCE TIME CALCULATION

- 28. Are there left-turns towards the tracks? Yes No
- 29. Distance traveled by truck during left-turn (LTL, feet): 29.
- 30. Travel speed of left-turning truck (S_{LTT}, mph): 30.
- 31. Distance required to clear left-turning truck from travel lanes on track clearance approach (feet): 31.
- 32. Additional time required to clear left-turning truck from travel lanes on track clearance approach (seconds): 32.
- 33. Worst-case Left Turning Truck time (seconds): if Line 28 = 'Yes', use line 32; otherwise Use 0 33.
- 34. Queue start-up distance, L (feet): add lines 1 through 3 34.
- 35. Time required for design vehicle to start moving (seconds): calculate as 2+(L+20) 35.
- 36. Design vehicle clearance distance, DVCD (feet): add lines 2, 3 and 10..... 36.
- 37. Time for design vehicle to accelerate through the DVCD (seconds), level terrain 37.
- 38. Factor to account for slower acceleration on uphill grade 38.
- 39. Time for design vehicle to accelerate through DVCD (seconds), adjusted for grade: multiply lines 37 and 38 39.
- 40. Queue clearance time (seconds): add lines 33, 35 and 39 40.

Remarks

LTL = $\lceil TRQ/180$
 Default value
 Equation: (line 4 + line 5 + line 12 - line 11) + line 29 + line 10
 Equation: $[(\text{line } 31 * 3600) / (\text{line } 30 * 5280)] - \text{line } 18 - \text{line } 19]$

SECTION 4: MAXIMUM PREEMPTION TIME CALCULATION

- 41. Right-of-way transfer time (seconds): line 27 41.
- 42. Queue clearance time (seconds): line 40 42.
- 43. Desired minimum separation time (seconds) 43.

- 44. Maximum preemption time for Queue Clearance (seconds): add lines 41 through 43 44.

Remarks

Typical Value _____

SECTION 5: SUFFICIENT WARNING TIME CHECK

Remarks

- 45. Required minimum time, MT (seconds): per regulations 45.
- 46. Clearance time, CT (seconds): (line 2 -35) / 10
(rounded up to nearest second)..... 46.
- 47. Total minimum warning time, MWT, needed (seconds):
add lines 45 and 46 (excludes buffer time and equipment response time)..... 47.
- 48. Required advance preemption time (APT) from railroad (seconds):
subtract line 47 from line 44, round up to nearest full second, enter 0 if less than 0 48.
- 49. APT currently provided by railroad (seconds): Enter "0" if new crossing or signal 49.

If the required advance preemption time (line 48) is greater than the amount of advance preemption time currently provided by the railroad (line 49), additional warning time must be requested from the railroad. Alternatively, the maximum preemption time (line 48) may be decreased after performing an engineering study to investigate the possibility of reducing the values on lines 13, 16, 17, 21, 22 and 43.

Remarks:

SECTION 6: TRACK CLEARANCE GREEN TIME CALCULATION (IF NO GATE DOWN CIRCUIT PROVIDED)

Preempt Trap Check

Remarks

- 50. Warning Time Variability (Select One)

Consistent Warning Times
Low Warning Time Variability
High Warning Time Variability
- 51. APT required or provided (seconds): maximum of Line 48 or Line 49..... 51. See Instructions for details.
- 52. Multiplier for maximum APT due to train handling 52.
- 53. Maximum APT (seconds): multiply line 51 and 52 53.
- 54. Minimum duration for the track clearance green interval (seconds) 54.
- 55. Track Clearance Green Time to avoid Preempt Trap (seconds): add lines 53 and 54 55.

Clearing of Clear Storage Distance

- 56. Time waiting on left-turn truck (seconds): line 33 56.
- 57. Time required for design vehicle to start moving (seconds): line 35 57.
- 58. Design vehicle clearance distance (DVCD, feet): line 36 58.

If $CSD \leq DVL$, you must clear the design vehicle through the entire CSD during the traffic clearance phase; however, if $CSD > DVL$, you should consider providing enough time to clear the design vehicle from the crossing.

Is the clear storage distance (CSD) less than or equal to the design vehicle length (DVL)?

YES. The design vehicle MUST clear through the entire CSD. (CSD will be entered in Line 59).

NO. The design vehicle may clear through a portion of the CSD.

Do you want to clear the design vehicle through the entire CSD?

YES. Clear the entire CSD. (CSD will be entered in Line 59).

NO. Clear the crossing ONLY. (DVL will be entered in Line 59).

- 59. Portion of CSD to clear during track clearance phase (feet) 59.
- 60. Design vehicle relocation distance (DVRD, feet): add lines 58 and 59 60.
- 61. Time required to accelerate design vehicle through DVRD (seconds), level terrain: 61.
- 62. Factor to account for slower acceleration on uphill grade 62.
- 63. Time required to accelerate design vehicle through DVRD (seconds), adjusted for
grade: multiply lines 61 and 62 63.
- 64. Time to clear portion of clear storage distance (seconds): add lines 56, 57 and 63 64.
- 65. Track clearance green interval (seconds): maximum of lines 55 or 64, round up to nearest full second 65.

Maximum Duration of Track Clearance Green after gates are down (in absence of a gate down circuit)

- 66. Total time to complete track clearance green (seconds): line 27 + line 65 66.
- 67. Total time before gates are down (seconds): subtract 5 seconds from line 44
(per AREMA Manual) 67.
- 68. Maximum Duration of Track Clearance Green after gates are down (seconds): Line 66 - Line 67 68.

SECTION 7: SUMMARY OF CONTROLLER PREEMPTION SETTINGS

- 69. Duration Time (seconds) 69.
- 70. Preempt Delay Time (seconds) 70.

Remarks

Right of Way Transfer Phase

- 71. Minimum Green Interval (seconds) 71.
- 72. Pedestrian Walk Interval (seconds) 72.
- 73. Pedestrian Clearance Interval (Flashing "DON'T WALK", seconds) 73.
- 74. Yellow Change Interval (seconds) 74.
- 75. All Red Vehicle Clearance (seconds) 75.

Remarks

Track Clearance Phase

- 76. Green Interval (seconds) (in the absence of gate down circuit) 76.
- 77. Green Interval (seconds) with gate down circuit 77.
- 78. Yellow Change Interval (seconds) 78.
- 79. All Red Vehicle Clearance (seconds) 79.

Remarks

Exit Phase

- 80. Dwell/Cycle Minimum Green Time (seconds) 80.
- 81. Yellow Change Interval (seconds) 81.
- 82. All Red Vehicle Clearance (seconds) 82.

Remarks

Remarks: