

PLAN

"M1" TABLE OF QUANTITIES 'D' = 1219									
BARS A @ 305±		BARS B-1 @ 305±		BARS B-2 @ 305±		BARS C @ 229±		STEPS @305 (#6)	
NO.	LGTH.	NO.	LGTH.	NO.	LGTH.	NO.	LGTH.	NO.	LGTH.
10	2692	3	1981	3	2083	12	1156	3	864
TOTAL STEEL							58.51 kg		
TOTAL CONC.							1.51m ³		
ADDITIONAL STEEL							35.82 kg/m		
ADDITIONAL CONC.							0.951m ³ /m		

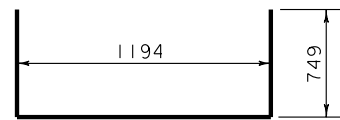

BARS A

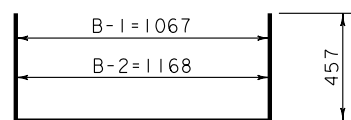

BARS B-1 & B-2

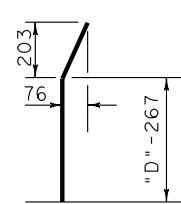

BARS C

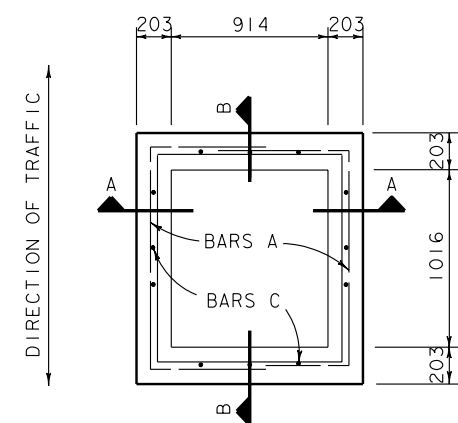

PLAN

"M2" TABLE OF QUANTITIES 'C' = 457									
BARS A @ 305±		BARS C @ 305±		STEPS @305 (#6)					
NO.	LGTH.	NO.	LGTH.	NO.	LGTH.				
6	2692	12	394	1	864				
TOTAL STEEL					23.68 kg				
TOTAL CONC.					0.41m ³				
ADDITIONAL STEEL					35.82kg/m				
ADDITIONAL CONC.					0.951m ³ /m				

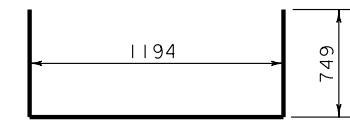

BARS A

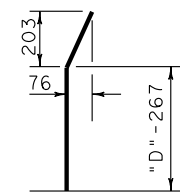

BARS C

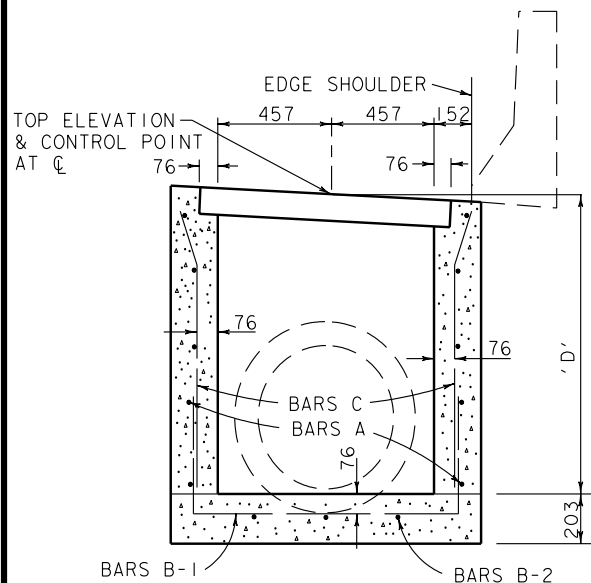

SECTION A-A

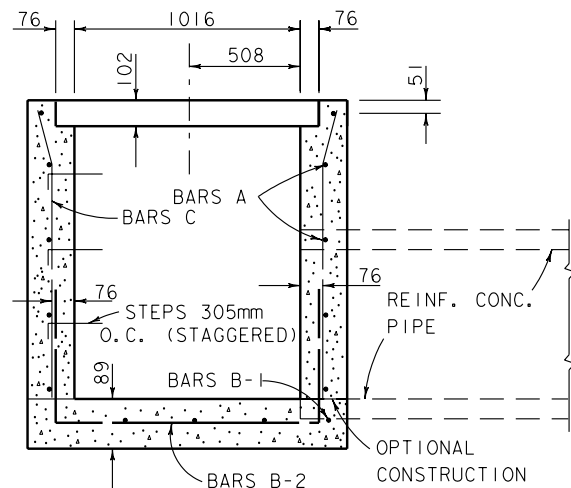

SECTION B-B

TYPE "L1" STRUCTURE

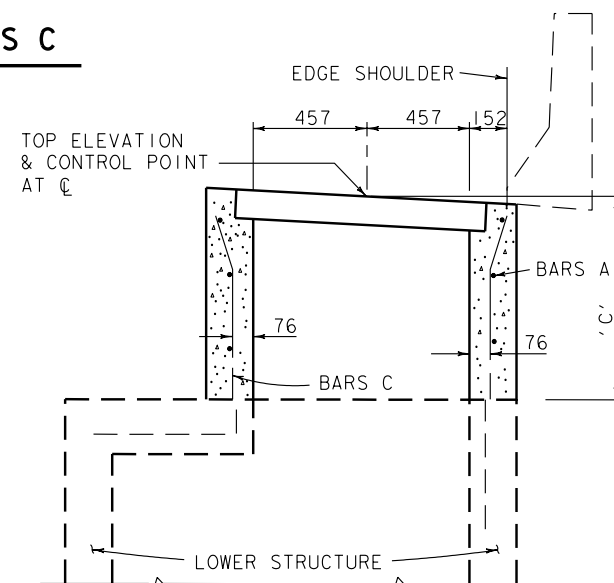

SECTION A-A

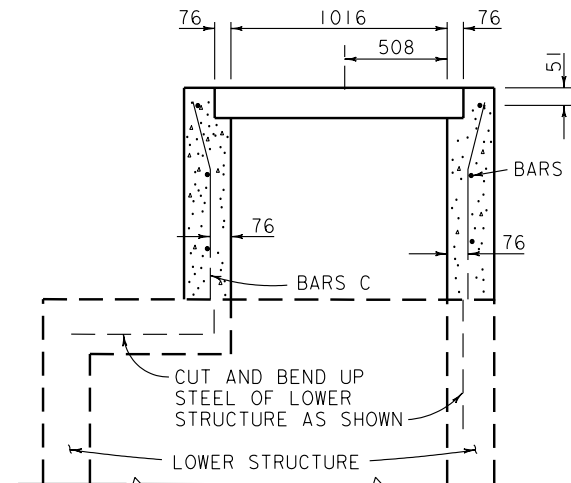

SECTION B-B

TYPE "L2" STRUCTURE

GENERAL NOTES:

1. LOCATION GIVEN IN PLANS IS TO CENTROID OF TOP STRUCTURE. BOTTOM STRUCTURE SHALL BE POSITIONED TO PROVIDE A COMMON LONG WALL WITH THE TOP STRUCTURE.
2. ALL CONCRETE SHALL BE CLASS "A".
3. ALL DIMENSIONS ARE mm UNLESS SHOWN OTHERWISE.
4. ALL REINFORCING STEEL SHALL BE No. 4 BARS. STEPS ARE TO BE No. 6 BARS. DIMENSIONS RELATING TO STEEL ARE TO CENTERS OF BARS. FIELD CUT AND BEND BARS AS REQUIRED TO ACCOMMODATE TIES TO LOWER STRUCTURE AND TO CLEAR PIPES.
5. REDUCE CONCRETE QUANTITIES IN TABLES FOR AREA OF EACH PIPE IN STRUCTURE.
6. GRATE AND FRAME SHALL CONFORM TO ITEM 471.

PIPE DIAMETER (mm)	REDUCTION (m ³)
450	0.05
525	0.08
600	0.09
675	0.11
750	0.14
825	0.17
900	0.20

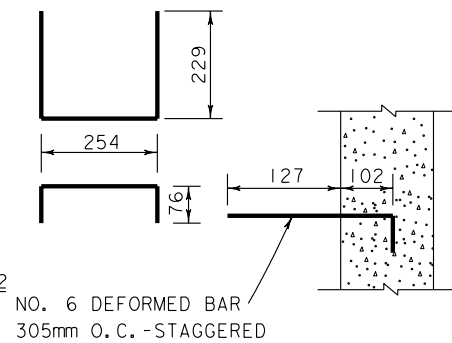

STEPS

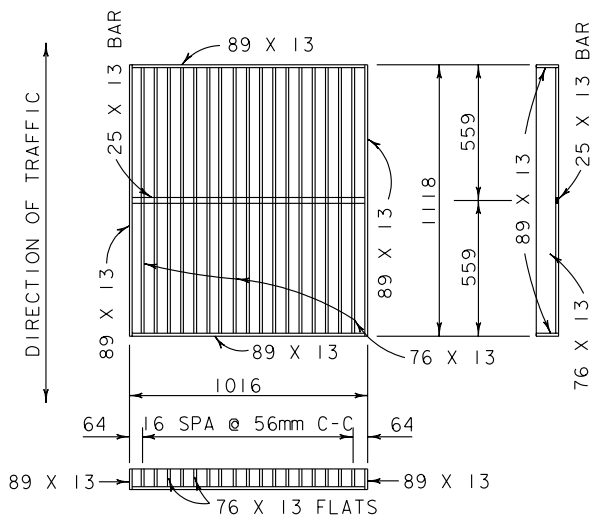

GRATE DETAIL

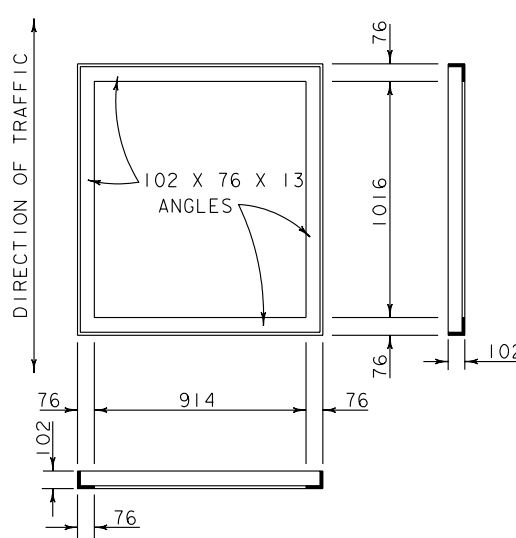

FRAME DETAIL

REVISIONS:

Texas Department of Transportation

TYPES "L1" & "L2" GRATED INLETS

MI-6 (FW) (M)

© 1999 by Texas Department of Transportation 15121-416-2025. All rights reserved.

ORIG. DRAW. DATE:	DESIGN:	FED. REG.	STATE	FEDERAL AID PROJ. NO.	HIGHWAY
MAR. 1996	CHECKED:	6	TEXAS		
	DRAWN:	DISTRICT	COUNTY	CONTROL SECTION	JOB SHEET
	CHECKED:	FTW			

7pub11c:/metsd/mi6fw.m.dgn