

DISCLAIMER: THIS STANDARD IS GOVERNED BY THE TEXAS ENGINEERING PRACTICE ACT. NO WARRANTY OF ANY KIND IS MADE BY TxDOT FOR ANY PURPOSE WHATSOEVER. TxDOT ASSUMES NO RESPONSIBILITY FOR THE CONVERSION OF THIS STANDARD TO OTHER FORMATS OR FOR INCORRECT RESULTS OR DAMAGES RESULTING FROM ITS USE.

http://www.dot.state.tx.us/ftw/specinfo/standard.htm  
 11/6/2020 11:56:30 AM  
 P:\PROJECTS\TXDOT\16121\5 FTW Standards Revision\CADD\Modifications in Progress\1fg2-ftw.dgn

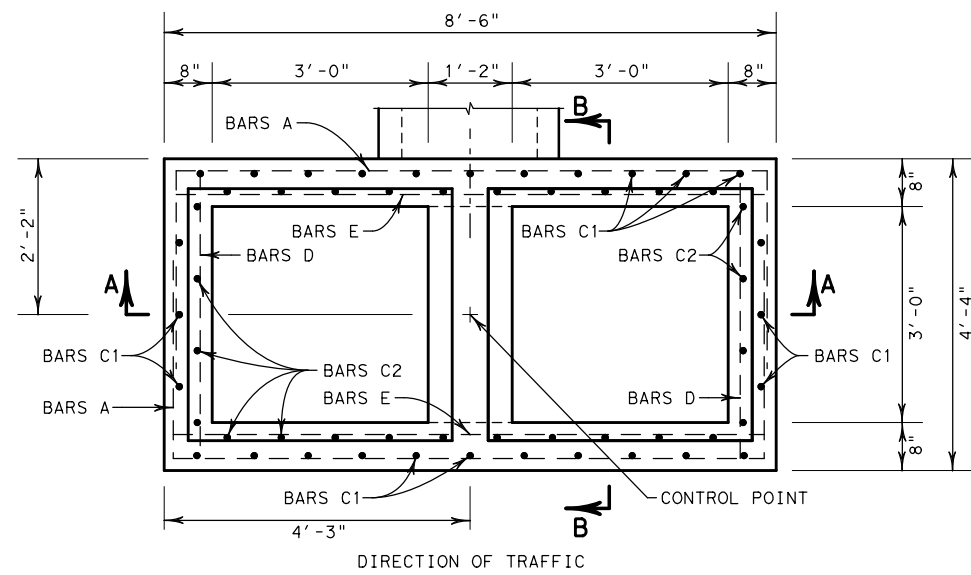

**PLAN VIEW**  
N. T. S.

- ① SLOPE TO MATCH PAVEMENT
  - ② STAGE II CONSTRUCTION
  - ③ BARS P LENGTH = PIPE O.D. + 0'-9"
- PLACE 3 BARS P AS SHOWN AT EACH PIPE OPENING, WITH 2" CLEAR COVER OVER PIPE. POSITION AS NEEDED TO PROVIDE 2" CLEAR AT WALLS.

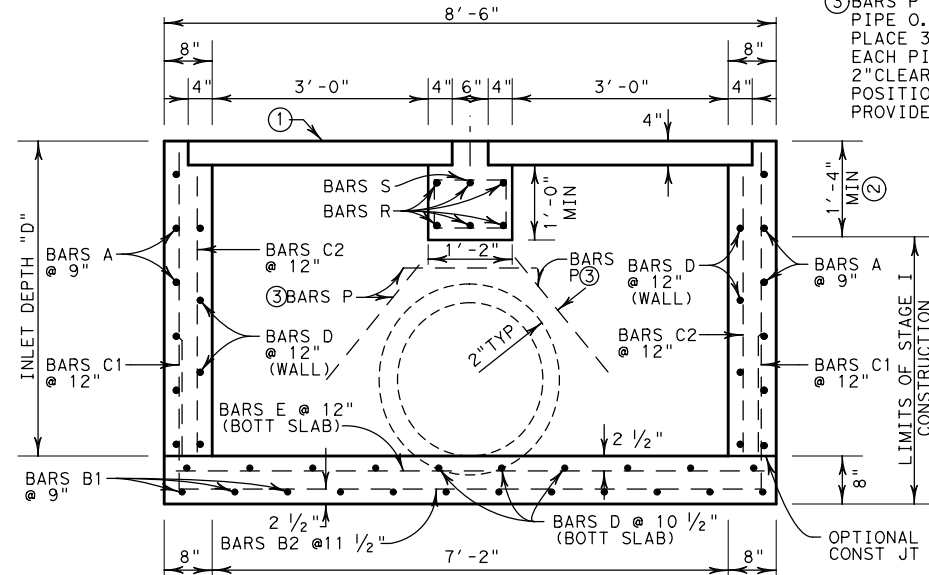

**SECTION A-A**  
N. T. S.

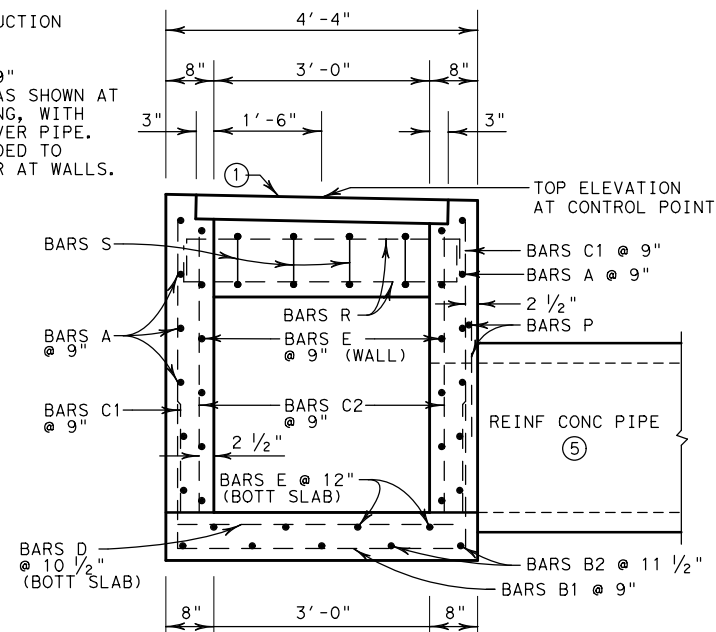

**SECTION B-B**  
N. T. S.

⑤ 24" DIA. MAX FOR PIPES ON SHORT WALL

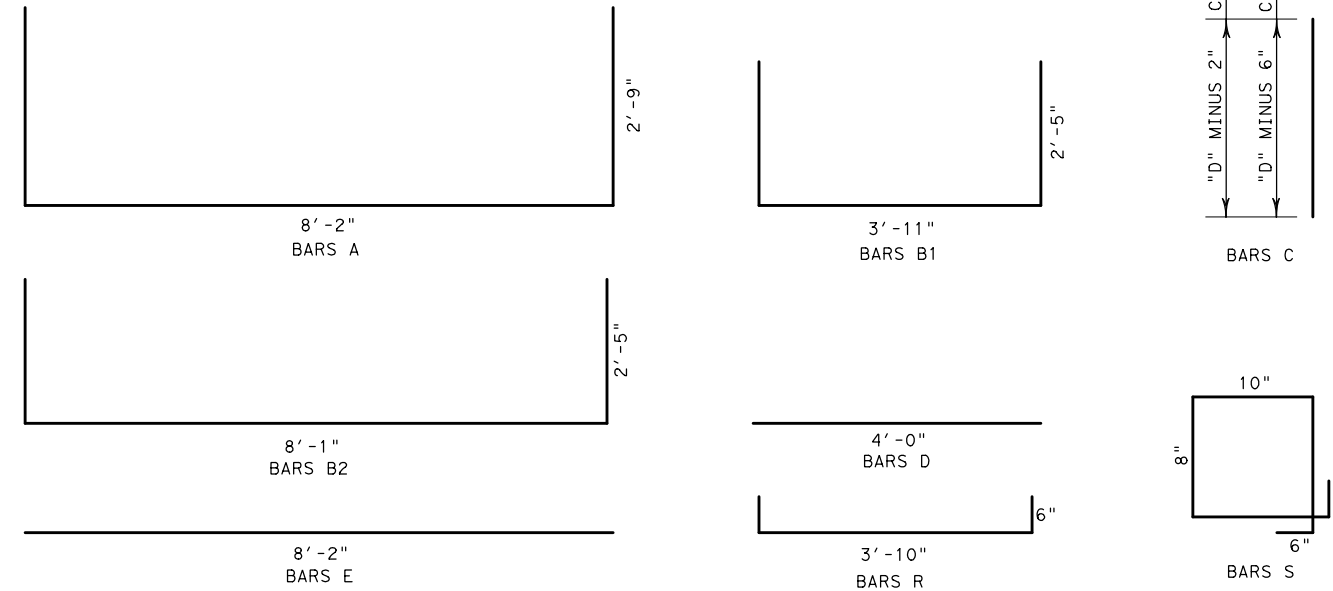

**GENERAL NOTES**

1. INLET (INCLUDING GRATE) DESIGNED FOR AASHTO LRFD HL 93 LOADING.
2. STAGE I MAY BE EITHER CAST-IN-PLACE OR PRECAST. FABRICATE PRECAST STRUCTURES WITH A MINIMUM 2' AT THE TOP OF STAGE I USING REBAR AS DETAILED HEREON. INCLUDE BARS C WITH STAGE I. SPLICING OF BARS WILL NOT BE PERMITTED. LOWER PORTIONS OF STAGE I MAY BE PRECAST. SUBMIT SEALED ENGINEERING CALCULATIONS AND DRAWINGS FOR APPROVAL PRIOR TO FABRICATION.
3. STAGE II SHALL BE CAST-IN-PLACE. STAGE II MAY BE CAST MONOLITHICALLY WITH CONCRETE PAVEMENT. IF NOT CAST MONOLITHICALLY, PLACE A SEALED 1/2" ISOLATION JOINT AROUND THE TOP OF THE INLET STRUCTURE, TO THE DEPTH OF CONCRETE PAVEMENT. USE CLASS 5 OR 8 JOINT SEALANT TO SEAL THE JOINT. CONSTRUCT TOP TO CONFORM TO SLOPE OF SURFACE.
4. USE CLASS "C" CONCRETE FOR CAST-IN-PLACE STRUCTURES; USE CLASS "H" CONCRETE (MINIMUM 5000 PSI DESIGN STRENGTH) FOR PRECAST STRUCTURES.
5. USE GRADE 60 STEEL FOR ALL REINFORCING.
6. DIMENSIONS RELATING TO REINFORCING STEEL ARE TO THE CENTERS OF BARS.
7. FIELD CUT AND BEND BARS AS NECESSARY TO ACCOMMODATE STORM DRAIN PIPE.
8. FABRICATE FRAME AND GRATE FROM WELDED STEEL IN ACCORDANCE WITH ITEM 471.
9. FOR CAST-IN-PLACE STRUCTURES, A CONSTRUCTION JOINT MAY BE PLACED AT EACH 5' (MIN) INCREMENT OF DEPTH.
10. DO NOT USE INLET IN OR ADJACENT TO AREAS DESIGNATED FOR PEDESTRIAN OR BICYCLE ACCESS.
11. FOR PIPE OR BOX CONNECTIONS TO PRECAST STRUCTURES, SEE STANDARD PBGC.
12. DEPTHS OTHER THAN THOSE SHOWN MAY BE USED WHENEVER NECESSARY, UP TO A MAXIMUM DEPTH "D" OF 15'. DETERMINE QUANTITIES FOR OTHER DEPTHS BY INTERPOLATION.
13. DO NOT COMMENCE WITH STAGE II CONSTRUCTION UNTIL PERMISSION IS GRANTED BY THE ENGINEER.
14. INSTALL A TEMPORARY WOOD COVER AFTER STAGE I IS COMPLETED, TO REMAIN IN PLACE UNTIL STAGE II CONSTRUCTION BEGINS.
15. THE LOCATION OF INLET AS SHOWN IN THE PLAN REFERS TO THE CONTROL POINT SHOWN HEREON.

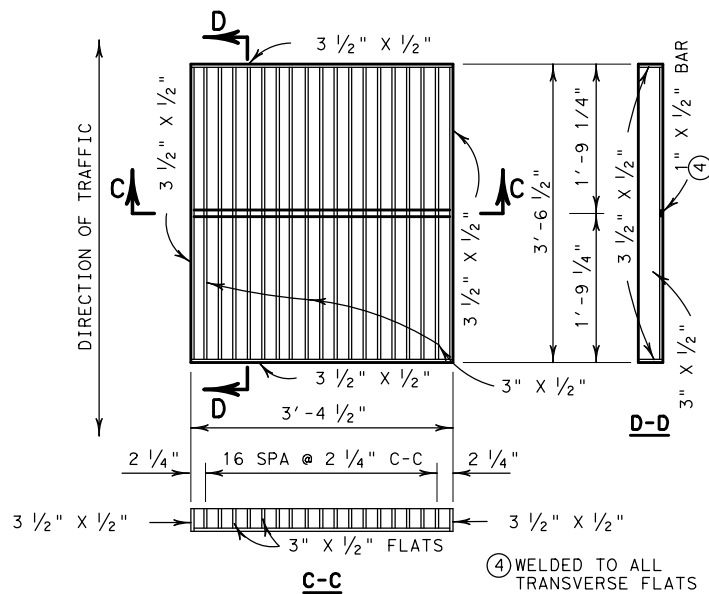

**GRATE DETAIL**  
N. T. S.

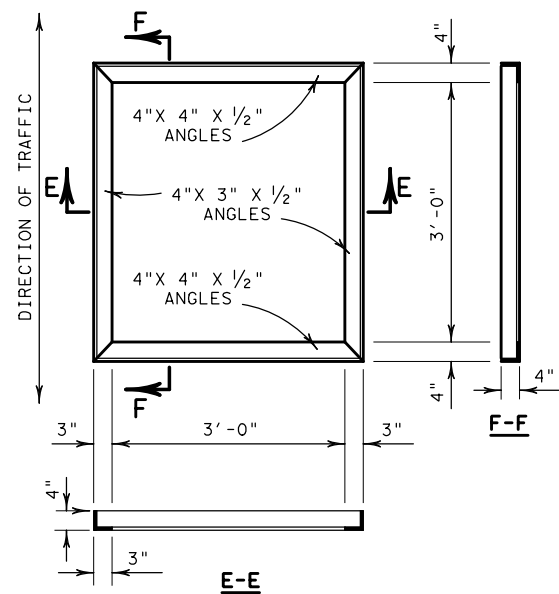

**FRAME DETAIL**  
N. T. S.

BILL OF REINFORCING STEEL																		
DEPTH "D"	BARS A		BARS B1		BARS B2		BARS C1		BARS C2		BARS D		BARS E		BARS R		BARS S	
(ft)	No	Wt	No	Wt	No	Wt	No	Wt	No	Wt	No	Wt	No	Wt	No	Wt	No	Wt
4.0	12	110	12	70	5	43	30	77	28	65	20	53	16	87	6	19	4	11

SUMMARY OF QUANTITIES FOR "D" = 4.00'			
TOTAL REINFORCING STEEL	ADD STEEL P.L.F. "D"	TOTAL CONCRETE	ADD CONCRETE P.L.F. "D"
(lb)	(lb)	(cy)	(cy)
536	83.0	3.3	0.57

MAXIMUM DEPTH "D" = 15.00'

©2020 by Texas Department of Transportation; All Rights Reserved



**Fort Worth District Standard**

## GRATED INLET FOR PAVED SURFACES

### TYPE FG-2

# I-FG-2 (FTW)

ORIGINAL DRAWING: 05/2019 1fg2-ftw.dgn		PROJECT NO.		SHEET NO.	
REVISIONS					
DATE	REVISIONS		STATE	STATE DIST. NO.	COUNTY
05/2019	REPLACES G1-5-02(FW)		TEXAS	FTW	
09/2020	REVISED TITLE BLOCK TO INDICATE APPLICATION				
11/2020	REVISE JOINT NOMENCLATURE		CONT.	SECT.	JOB
					HIGHWAY NO.