

1. DEFINITION OF TERMS

T_{FS} - FAST TRACK CONCRETE PAVING DEPTH AT INTERSECTIONS AND LEAVE OUTS.
 T - NOMINAL CONCRETE PAVING DEPTH AS SHOWN IN THE PLANS.
 DETERMINE FAST TRACK CONCRETE PAVING DEPTH USING TABLE 1 AND THE NOMINAL CONCRETE PAVING DEPTH " T " SHOWN IN THE PLANS.

2. AT INTERSECTIONS AND LEAVE-OUT LOCATIONS USE THE SAME LONGITUDINAL AND TRANSVERSE BAR SPACING FOR THE FAST TRACK PAVING AREA AS THAT USED FOR THE ADJACENT CONCRETE PAVING DEPTH " T " (EXCEPT BAR SIZE SHALL BE #7 ON SINGLE MAT). FOR SINGLE MAT FAST TRACK PAVING, PLACE THE LONGITUDINAL AND TRANSVERSE BARS FOR THE FAST TRACK PAVING AREA AT THE HORIZONTAL PLANE ELEVATION THAT IS TWO TIE-BAR DIAMETERS LOWER THAN THAT USED FOR THE ADJACENT CONCRETE PAVING DEPTH " T ", AS SHOWN IN FIGURE 1. USE SINGLE MAT STEEL IN FAST TRACK PAVING AREAS ADJACENT TO PAVEMENT SLABS WITH SINGLE MAT REINFORCING. USE DOUBLE MAT STEEL IN FAST TRACK PAVING AREAS ADJACENT TO PAVEMENT SLABS WITH DOUBLE MAT REINFORCING.

3. THE REQUIRED FAST TRACK PAVING AREAS WILL BE SHOWN ON THE PLANS. THE CONTRACTOR HAS THE OPTION TO UTILIZE FAST TRACK CONCRETE PAVING AT U-TURNS, AT INTERSECTIONS, AT MINOR STREETS, AND AT DRIVEWAYS WITH FRONTAGE ROAD LEAVE-OUT AREAS THAT ARE NOT SHOWN ON THE PLANS, WITH PRIOR WRITTEN APPROVAL FROM THE ENGINEER. TYPICAL PAVING PLANS FOR THE INTERSECTION OF A MAJOR STREET WITH THE FRONTAGE ROAD ARE SHOWN AS FIGURE 2, AND FOR THE INTERSECTION OF A MINOR STREET OR DRIVEWAY WITH THE FRONTAGE ROAD AS FIGURE 3. FAST TRACK PAVE THE FRONTAGE ROAD FOR THE FULL FRONTAGE ROAD WIDTH AND PLACE IN STAGES AS REQUIRED.

4. USE ADDITIONAL #6 REINFORCING STEEL BARS (MINIMUM 42 INCHES LONG) AND SPACE THEM MIDWAY BETWEEN ALTERNATE LONGITUDINAL BARS ALONG THE TRANSVERSE CONSTRUCTION JOINT FORMED AT THE FAST TRACK PAVING INTERFACE (T_{FS}) WITH THE ADJACENT PAVEMENT SLAB (T).

5. SPLICE LENGTH IS A MINIMUM OF 33 TIMES THE NOMINAL STEEL DIAMETER.

6. PLACE THE CONCRETE AT A UNIFORM DEPTH THROUGHOUT THE FAST TRACK CONCRETE PAVING AREA.

7. FOR CONTINUOUS SECTIONS OF ROADWAY WHERE FAST TRACK PAVING IS THE PRIMARY PAVEMENT TYPE, USE THE BAR SIZE AND SPACING FROM THE CRCP STANDARDS THAT CORRESPONDS TO THE FAST TRACK SLAB THICKNESS.

8. USE LONGITUDINAL TIE-BARS OF THE SAME SIZE DIAMETER AND SPACING AS THE LONGITUDINAL BAR. A SINGLE PIECE TIE-BAR MAY BE USED IF THE 33 TIMES DIAMETER TIE-BAR PROJECTION DOES NOT INTERFERE WITH THE SAFE HANDLING OF TRAFFIC.

9. BASE THE DEPTH OF SAW CUTS FOR SAWED JOINTS ON THE FAST TRACK CONCRETE PAVEMENT THICKNESS.

10. THIS STANDARD IS NOT INTENDED TO REPLACE OTHER STANDARDS EXCEPT WHERE SPECIFICALLY STATED HEREIN. FOR PAVING DETAILS NOT SHOWN ON THIS DRAWING, REFER TO THE STANDARD SHEETS FOR CONTINUOUSLY REINFORCED CONCRETE PAVEMENT SHOWN ELSEWHERE IN THE PLANS.

TABLE 1

EQUIVALENT PAVEMENT THICKNESS	
T * (IN.)	T_{FS} ** (IN.)
$\leq 12"$	$T+3"$
$>12"$	15"

* WITH BASE STRUCTURE OF:
 1" ASPHALT STABILIZED BASE
 6" PORTLAND CEMENT TREATED BASE
 6" LIME TREATED SUBGRADE

** ON AS CUT SUBGRADE

*** SEE JOINT SEALING DETAILS ON CRCP STANDARDS

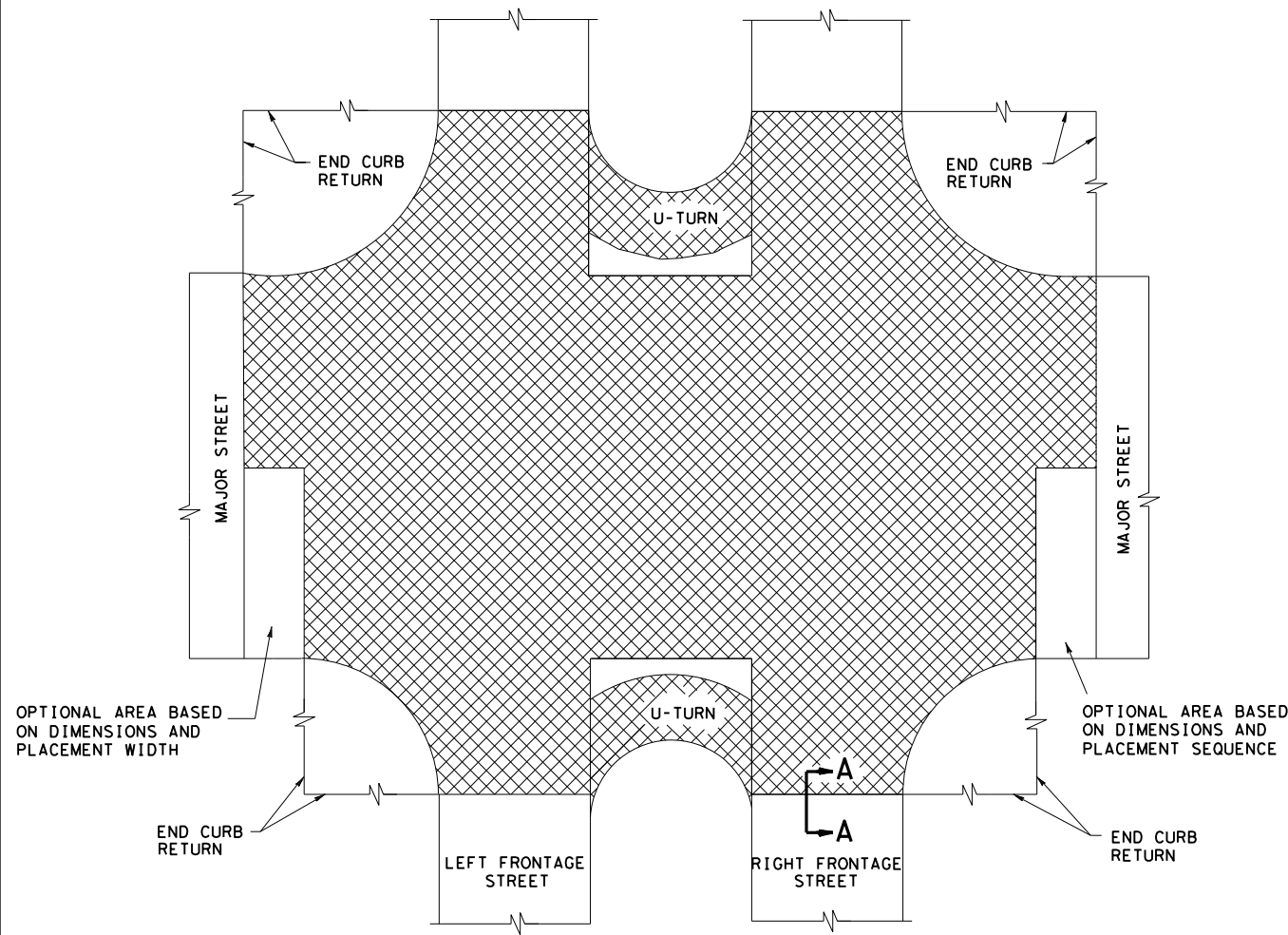

FIGURE 2

INTERSECTION OF MAJOR STREET WITH FRONTAGE STREET

FAST TRACK PAVING AREA

TYPICAL PAVING PLANS

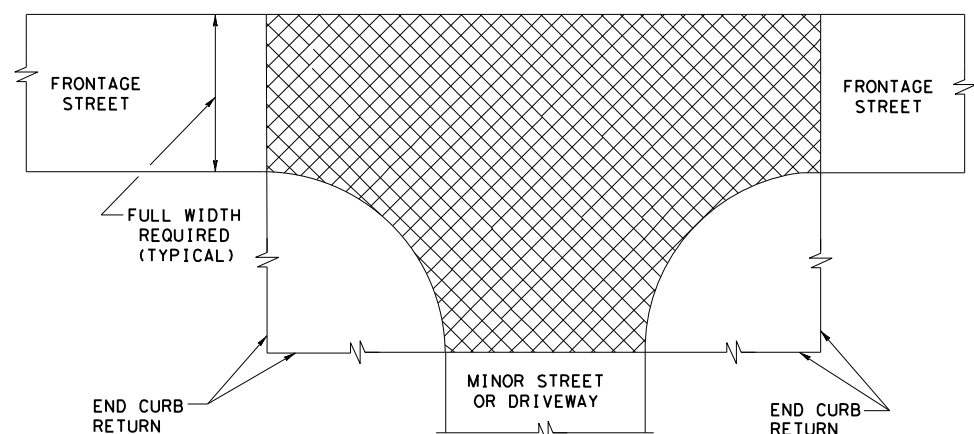
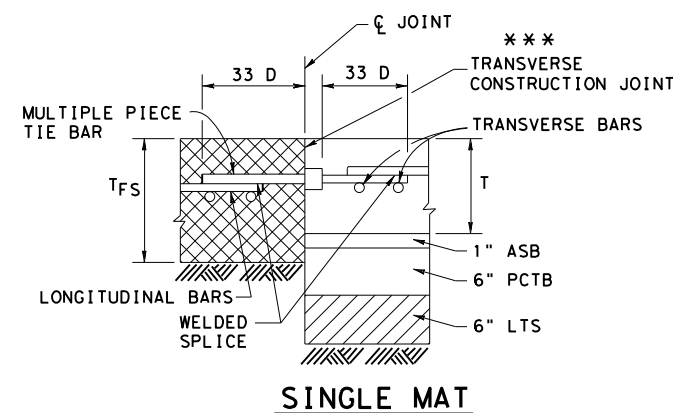

FIGURE 3

INTERSECTION OF MINOR STREET OR DRIVEWAY WITH FRONTAGE STREET



SECTION A - A

TRANSVERSE CONSTRUCTION JOINTS

FIGURE 1

LEGEND

- ASB - ASPHALT STABILIZED BASE
- CRCP - CONTINUOUSLY REINFORCED CONCRETE PAVEMENT
- D - DIAMETER
- LTS - LIME TREATED SUBGRADE
- PCTB - PORTLAND CEMENT TREATED BASE

Texas Department of Transportation
 Houston District

FAST TRACK CONTINUOUSLY REINFORCED CONCRETE PAVEMENT DETAILS
CRCP-FT

FILE: STDB-4.dgn	DN:	CK:	DW:	CK:
© TXDOT DEC. 2009	DIST	FED REG	PROJECT NO.	SHEET
REVISIONS 5/05 2004 SPECS 2/15 2014 SPECS	HOU	6		
	COUNTY	CONTROL	SECT	JOB
				HIGHWAY