

BAR U-LEG

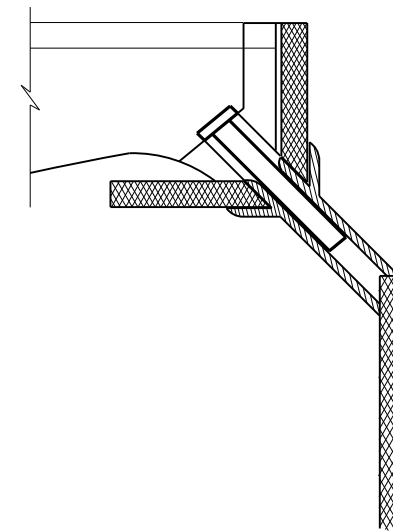

DETAIL A
**GRATE RETAINER
 PIN-REMOVABLE
 STAINLESS**

SHEET 2 OF 2



**TRENCH DRAIN
 DETAILS**

TDD

NOT TO SCALE

FILE: STDD14b.DGN	DN: TxDOT	CK: TxDOT	DW: TxDOT	CR: TxDOT	STD:
© TxDOT Feb. 2010	DIST	FED REG	PROJECT NO.		SHEET
REVISIONS		HOU	6		
06/12 ADDED CALLOUT					
03/15 2014 SPECS		COUNTY	CONTROL	SECT	JOB HIGHWAY