

GENERAL NOTES:

All steel is ASTM-A36 and shall be galvanized after fabrication.

Cost of Furnishing And Installing Frames, Grates, Additional Pavement Reinforcing, Roofing Felt And Polyethylene Foam Shall Be Included In The Unit Price Bid For The Type Of Inlet Selected.

All Concrete Shall Be Class C.

Shop Drawings Will Be Required For Precast Construction Of Inlets.

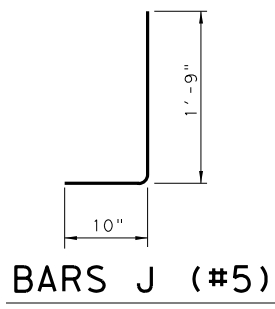
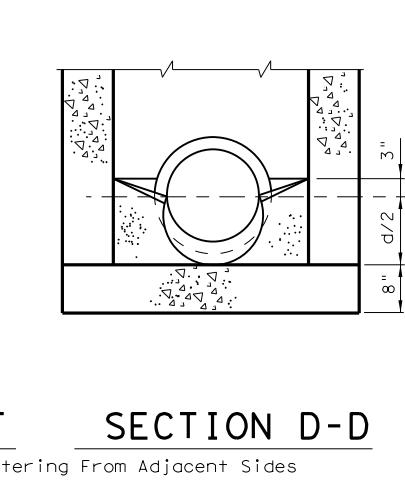
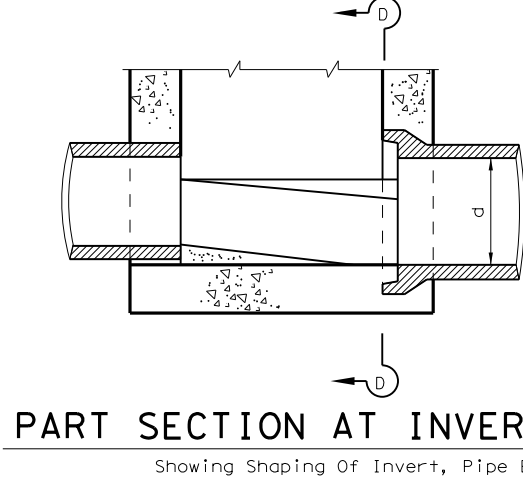
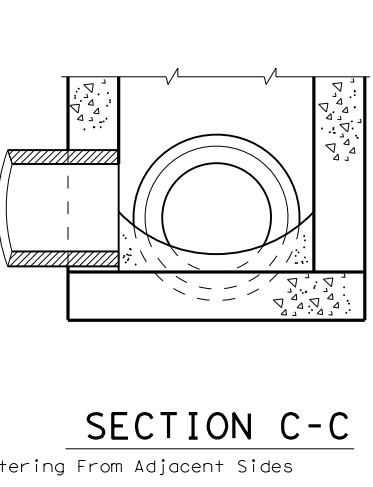
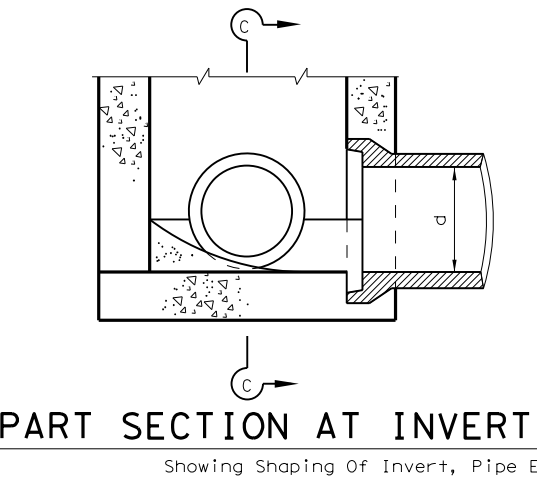

FOR TRAFFIC LOADS

Texas Department of Transportation
 Houston District

INLET TYPE AZ

HIL-AZ

FILE:	STDD6.DGN	DN:	TxDOT	CK:	TxDOT	DW:	TxDOT	CK:	TxDOT	STD:
REVISIONS	2014	DIST	FED REG	PROJECT NO.	SHEET					
HOUS	6	COUNTY	CONTROL	SECT	JOB	HIGHWAY				

STDD6.DGN