

TYPE "A" WEEP HOLE

TYPE "B" WEEP HOLE

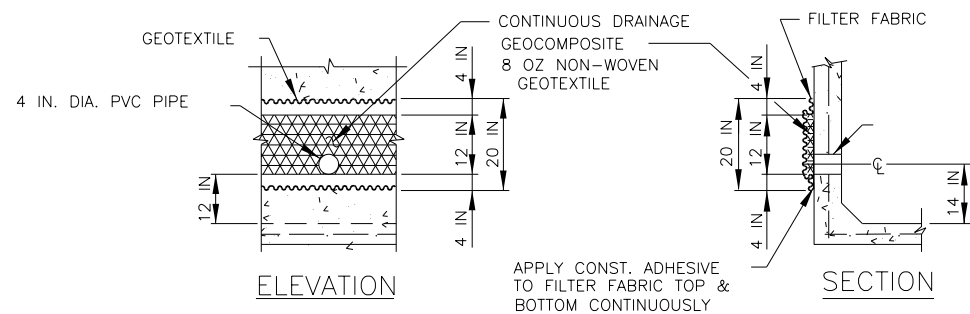

TYPE "C" WEEP HOLE

WEEP HOLE NOTES:

1. MATERIALS:
  - a. PIPE: 4 INCH DIA. SCH. 40 PVC
  - b. DRAIN GRAVEL:
 

SIEVE SIZE	% FINER
1 IN	100
3/4 IN	70 - 100
3/8 IN	20 - 90
NO. 4	0 - 60
NO. 8	0
  - c. FILTER FABRIC - (TYPE 1 PER ITEM 556)
2. CUT WEEP HOLE PIPE FLUSH WITH CONCRETE SURFACE.
3. TYPE "A" AND "C" WEEP HOLES FOR TYPICAL RECTANGULAR CONCRETE CHANNEL LINING. TO BE STAGGERED.
4. HARDWARE CLOTH MIN. OPEN      MAX. OPEN  
    1/8 IN                              1/4 IN

WEEP HOLE DETAILS

**Texas Department of Transportation**  
 Houston District

**HCFC**  
**CONCRETE CHANNEL LINING**  
**DETAILS**  
**HCFC-CCLD (2)**

FILE: STDG5.dgn	DN: TxDOT	CK: TxDOT	DW: TxDOT	CK: TxDOT
© TxDOT DEC, 2012	DIST	FED REG	PROJECT NO.	SHEET
REVISIONS 02/2015 2014 SPECS	HOU	6		
	COUNTY	CONTROL	SECT	JOB
				HIGHWAY