

A SECTION
BEDDING
CMP DETAIL

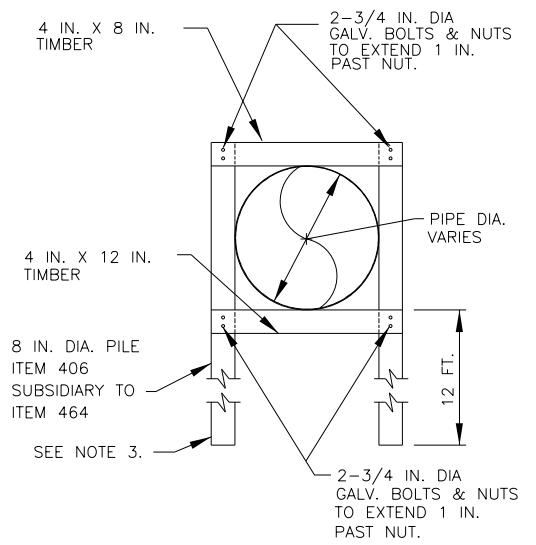

NOTE AA
THIS DETAIL OF CENTERLINE OF ANY PIPE END ALIGNING WITH CHANNEL SIDE SLOPE IS OF UTMOST IMPORTANCE. THIS DETAIL SHALL SUPERSEDE ANY OTHER DETAILS/PIPE LENGTHS SHOWN ELSEWHERE IN PLANS.

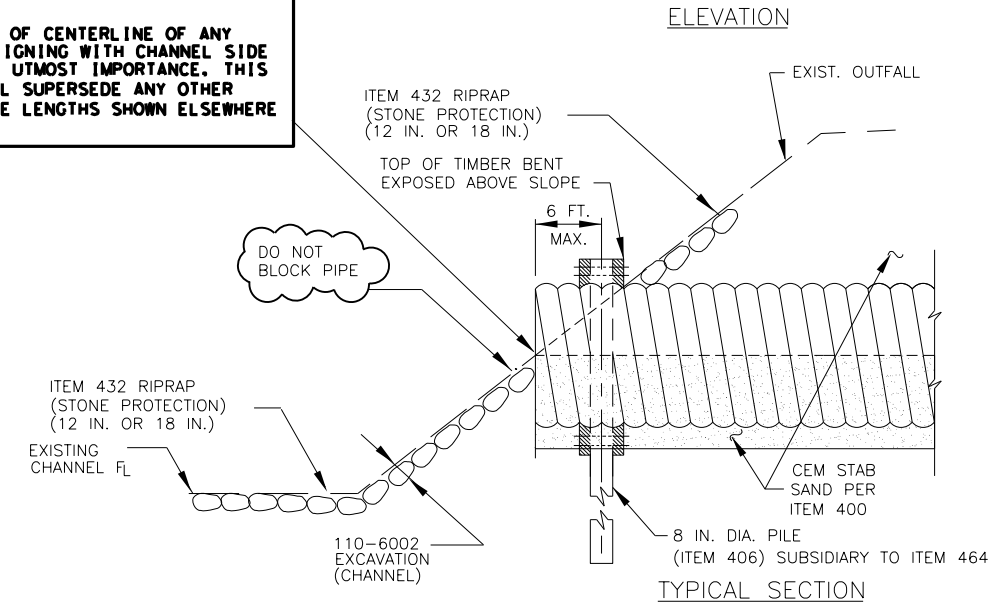

ELEVATION

TYPICAL SECTION

TIMBER BENT DETAIL
REQUIRED ONLY FOR 48-INCH CMP AND LARGER OUTFALLS

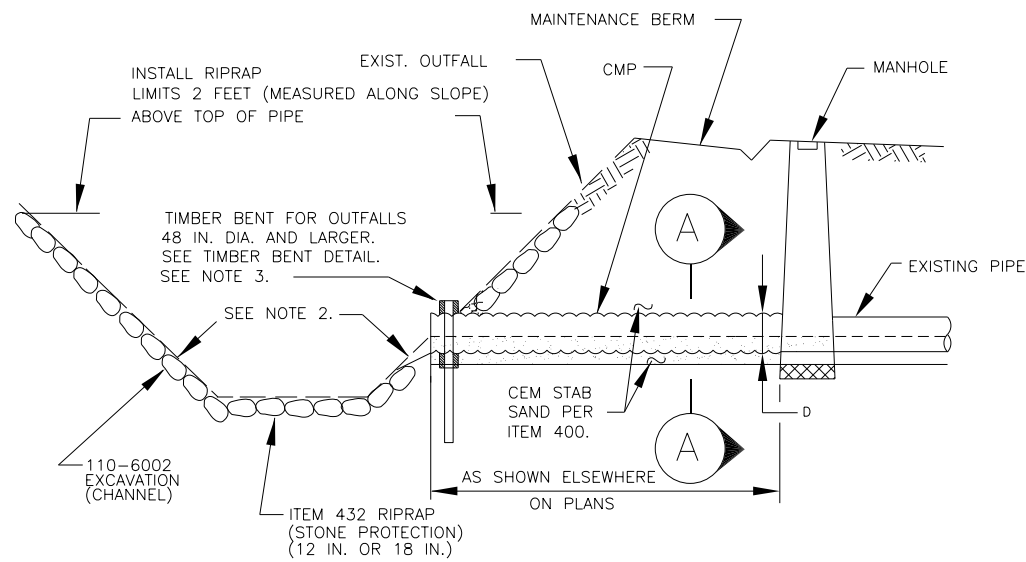

SECTION
TYPICAL STORM SEWER OUTFALL
STRUCTURE LAYOUT

STORM SEWER OUTFALL NOTES

1. INSTALL OUTFALLS 48 INCHES OR LARGER, AND STORM SEWER OUTFALLS OF ANY DIAMETER, WITH RIPRAP EROSION DIMENSIONED AS SHOWN IN "TYPICAL STORM SEWER OUTFALL STRUCTURE LAYOUT."
2. SET FLOWLINE OF OUTFALLS AT ELEVATION SPECIFIED ELSEWHERE IN PLANS (TYPICALLY 1 FOOT ABOVE CHANNEL FLOWLINE OR 1 FOOT ABOVE NORMAL WATER SURFACE ELEVATION, WHICHEVER IS HIGHEST)
3. PROVIDE TIMBER BENT PER ITEM 490, "TIMBER STRUCTURES," NO DIRECT PAY.

A THESE ARE GENERAL DETAILS AND NOTES. IF THERE ARE ANY DISCREPANCIES BETWEEN THIS STANDARD AND THE DETAILED SEALED DRAINAGE PLANS, THE SEALED PLANS WILL OVERRIDE. THE ONLY EXCEPTION IS NOTE AA ABOVE.

B DESIGNER TO CONSULT WITH DISTRICT ENVIRONMENTAL SECTION TO DETERMINE IF OUTFALL IS OR IS NOT JURISDICTIONAL. IF JURISDICTIONAL REQUEST ORDINARY HIGH WATER MARK AND CORPS OF ENGINEERS PERMIT FROM ENVIRONMENTAL SECTION FOR ANY WORK BELOW ORDINARY HIGH WATER MARK.

Texas Department of Transportation
Houston District

OUTFALL DETAILS

(BRAZORIA, FORT BEND, GALVESTON, MONTGOMERY AND WALLER COUNTIES)

OD

FILE:	DN: TxDOT	CK: TxDOT	DW: TxDOT	CK: TxDOT
© TxDOT 2014	DIST	FED REG	PROJECT NO.	SHEET
REVISIONS 5/1/2015	HOU	6		
	COUNTY	CONTROL	SECT	JOB
				HIGHWAY