

DISCLAIMER: The use of this standard is governed by the "Texas Engineering Practice Act". No warranty of any kind is made by TxDOT for any purpose whatsoever. TxDOT assumes no responsibility for the conversion of this standard to other formats or for incorrect results or damages resulting from its use.

LEVELS DISPLAYED

1	
2	
3	
4	
5	
6	
7	
8	
9	
10	
11	
12	
13	
14	
15	
16	
17	
18	
19	
20	
21	
22	
23	
24	
25	
26	
27	
28	
29	
30	
31	
32	
33	
34	
35	
36	
37	
38	
39	
40	
41	
42	
43	
44	
45	
46	
47	
48	
49	
50	

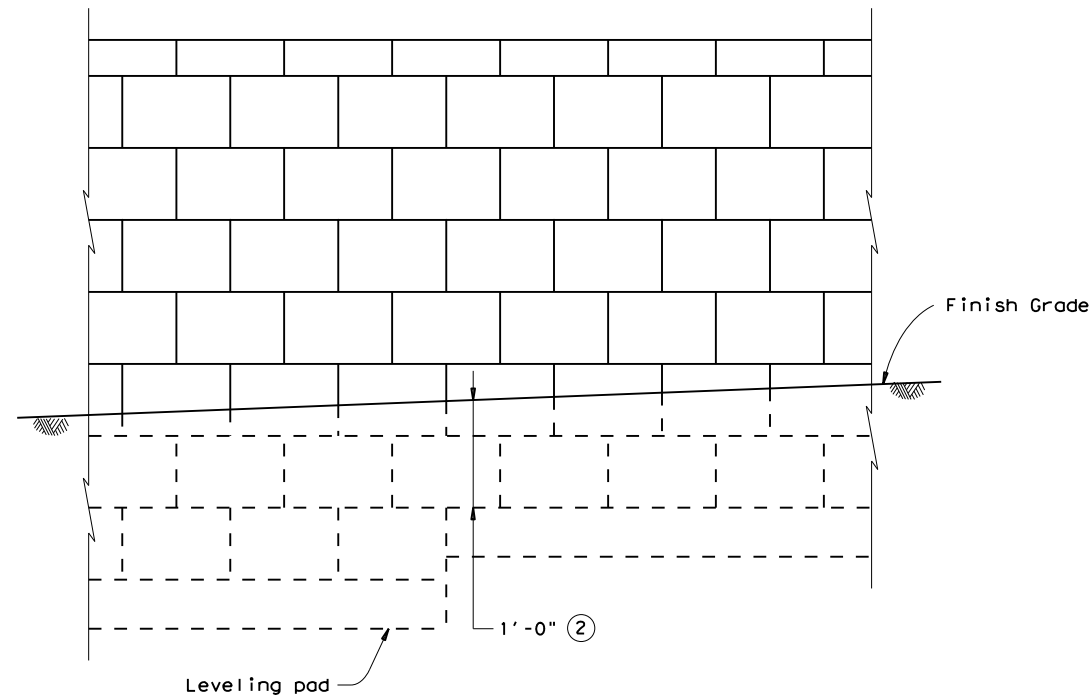
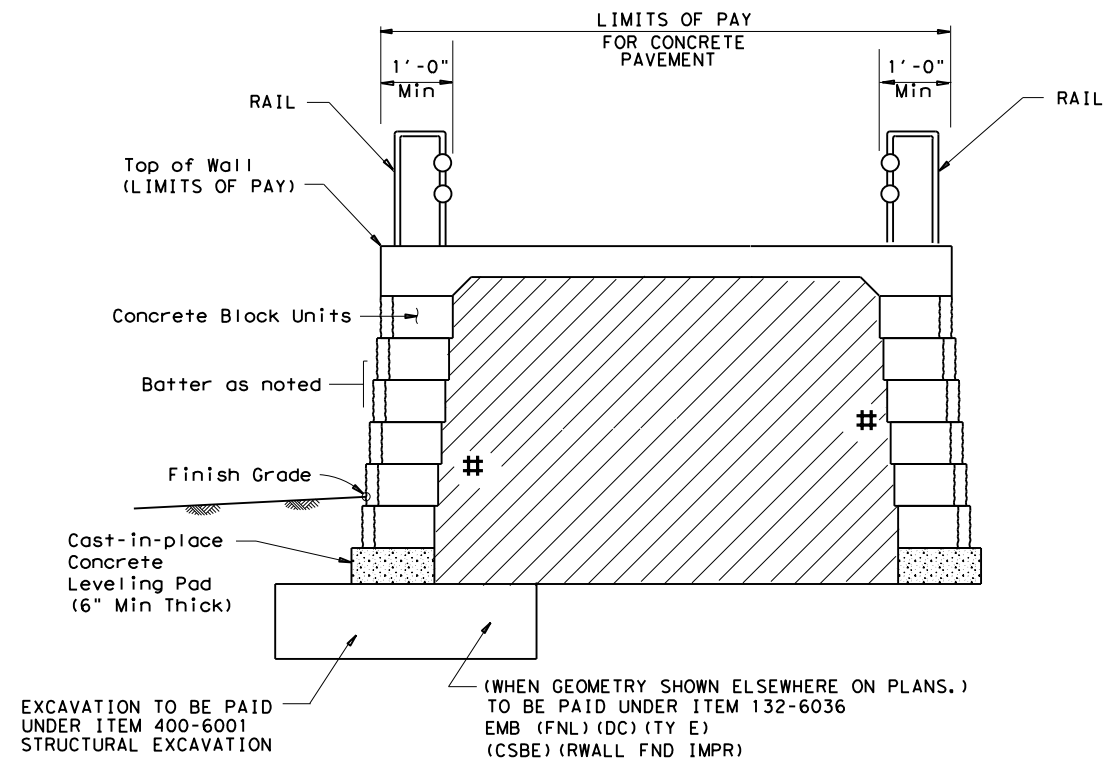

TYPICAL ELEVATION

- Cement Stabilized Backfill to be paid under Item 132-6006 Embank (Final) (DC) (Ty C)
- Drainage Aggregate Adjacent to wall is not required.

Underdrain shall be wrapped with filter fabric meeting the requirements of DMS-6200 Type I.

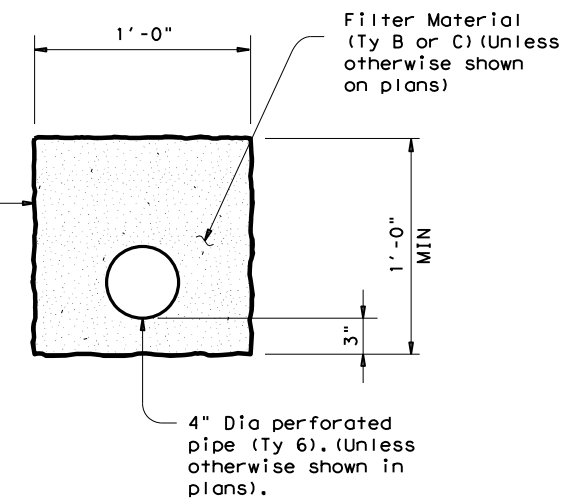

UNDERDRAIN DETAIL

- ① For systems utilizing continuous structural pins passing thru a minimum of 3 block layers, the minimum block depth shall be 8". The maximum vertical spacing of primary reinforcement on these systems shall be 24", and intermediate reinforcement will not be required.
- ② Unless noted elsewhere in the plans, 1'-0" minimum cover shall be provided from the top of leveling pad to finish grade.
- ③ For walls which are designated as landscape walls and are less than 6' tall, the following modifications to the design criteria will be allowed:

Factor of safety in sliding > 1.2.
 Factor of safety in overturning > 1.5.
 Connection strength factor of safety of 1.0 at 3/4" strain.
 Minimum earth reinforcement length of 4'.

The above modified criteria does not apply to walls over 6' tall regardless of designation.

EARTH REINFORCEMENTS:

Walls may be constructed without earth reinforcements if all stability criteria are met with the blocks alone. If all stability criteria are not satisfied, earth reinforcements shall be provided.

The long term design strength (LTDS) of earth reinforcement shall be calculated in accordance with current AASHTO Standard and Interim Specifications.

Soil-geogrid pullout coefficient values shall be determined in accordance with Geosynthetics Research Institute (GRI) Method GG-5, "Guidelines for Evaluating Geogrid Pullout".

For the combination of concrete block and geogrid chosen, connection strength data shall be provided. The allowable connection load shall be limited to the connection strength developed at 3/4" displacement, divided by a 1.5 safety factor. ③

For internal stability calculations, the failure plane will be assumed to originate at the back of the concrete blocks.

The factor of safety against pullout of the earth reinforcements shall be determined from test data evaluated at 3/4" strain.

The maximum vertical spacing of primary earth reinforcement layers shall be 40 inches. ① The minimum length of primary earth reinforcements shall be 8 feet, measured from the front of the blocks. ③

A layer of intermediate reinforcement shall be provided between primary reinforcements when the spacing between primary layers exceeds twice the horizontal depth of the concrete block unit. Intermediate reinforcement shall have a minimum length of 4 feet, and shall provide local stability for the concrete block units. ①

STABILITY CRITERIA:

Factor of safety in sliding along the base of the structure shall be greater than or equal to 1.5. ③

Factor of safety in overturning shall be greater than or equal to 2.0. ③

The base pressure resultant shall fall within the middle third of the retaining wall.

DESIGN PARAMETERS:

Structure shall be based on the following design parameters:

- Random Backfill: Unit weight = 120 pcf.
- (Embankment or Existing Soils) $\phi = 30^\circ$ $c = 0$ psf
- Select Backfill: Unit weight = 120 pcf
- $\phi = 34^\circ$ $c = 0$ psf

GENERAL NOTES:

Sections and Typical Elevation shown are for informational purposes only. Specific geometry is to be determined based on wall layouts and other plan information.

Unless otherwise shown in the plans, wall batter shall be a maximum of 3" per foot. Blocks shall be placed horizontally, and a positive means of obtaining batter such as pins, keyways, or concrete lips shall be provided.

Backfill must be cement stabilized backfill in accordance with Item 132 and Houston District Special Provision (132-001).



CONCRETE BLOCK RETAINING WALL

RW (CB)

FILE: STD J-13	DN: TxDOT	CK: TxDOT	DW: GHO	CK: MPM
© TxDOT FEBRUARY 2011		DISTRICT	PROJECT	SHEET
REVISIONS		HOU		
3/15 FOR 2014 SPECS		COUNTY	CONTROL SECT	JOB HIGHWAY