

SECTION

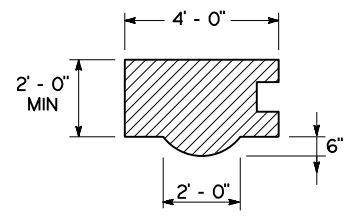

END COLUMN PLAN
REQ'D AT ALL ENDS

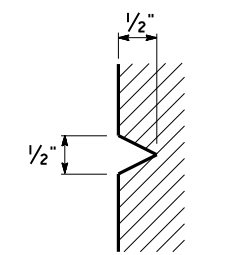

DETAIL A
NTS

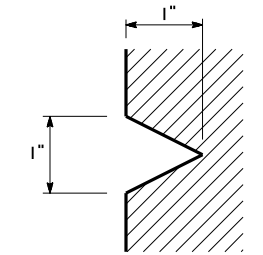

DETAIL B
NTS

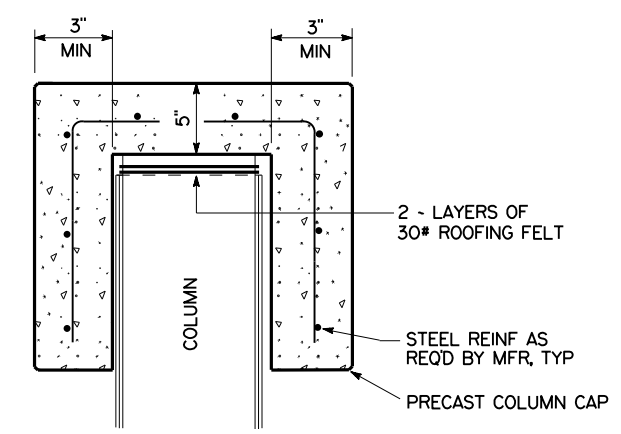
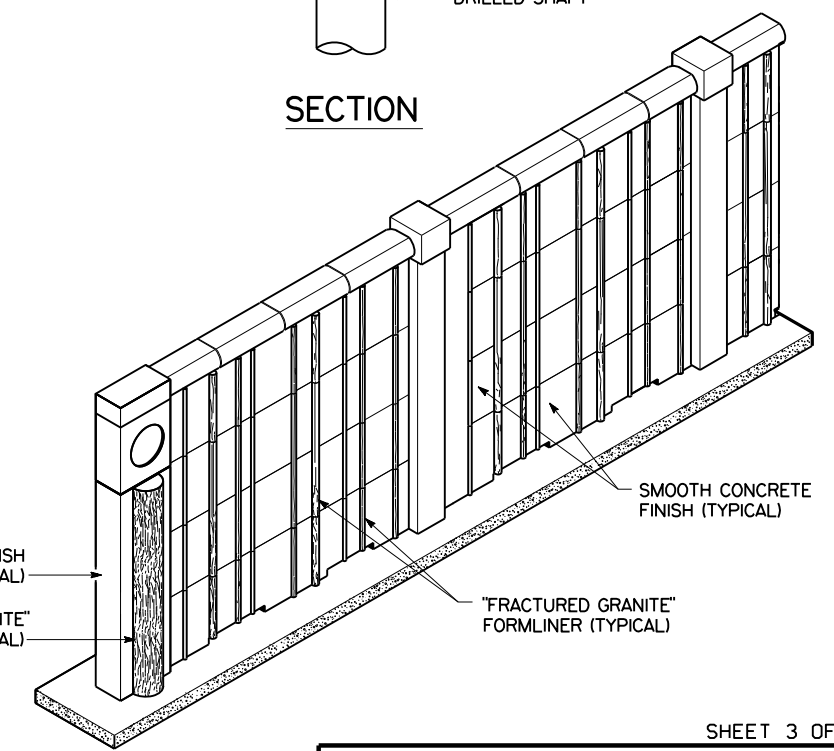

SECTION
PRECAST CONCRETE
COLUMN CAP

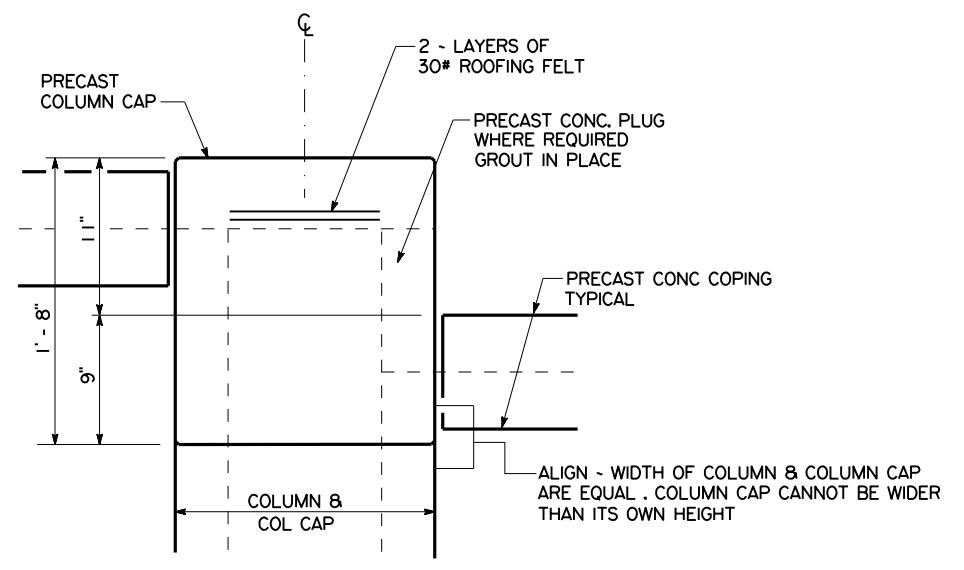

ELEVATION
PRECAST CONCRETE
COLUMN CAP

SOUND WALL DETAILS
VERTICAL SCHEME

SWD-VS

FILE: STDJS.DGN	DN: TxDOT	CK: TxDOT	DW: TxDOT	CK: TxDOT
© TxDOT DEC. 2010	DISTRICT FED REG	PROJECT NO.	SHEET	
12/2010 Update bottom panel	HOUSTON	6		
9/2014 Exposed Aggregate removed, current face added.	COUNTY	CONTROL	SECT	JOB
6/2017 Removed Mini-Hatch Blend, add color - shade #6186.				HIGHWAY