

**ELEVATION**

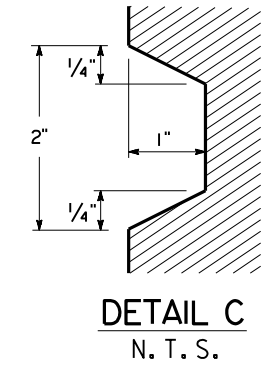

**SECTION**

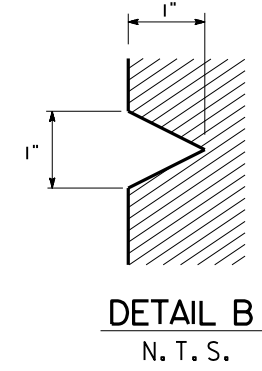
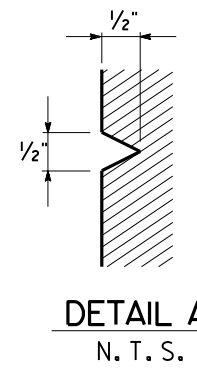
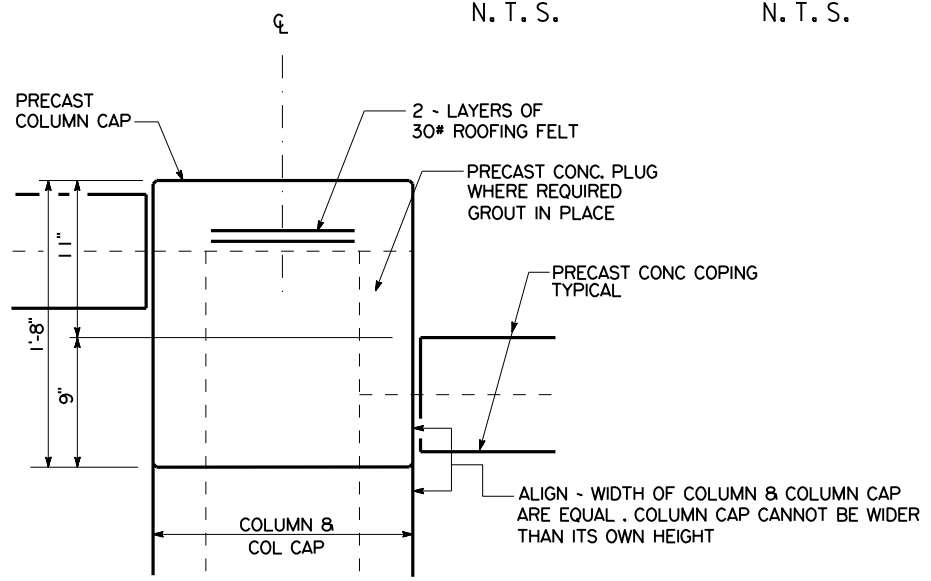
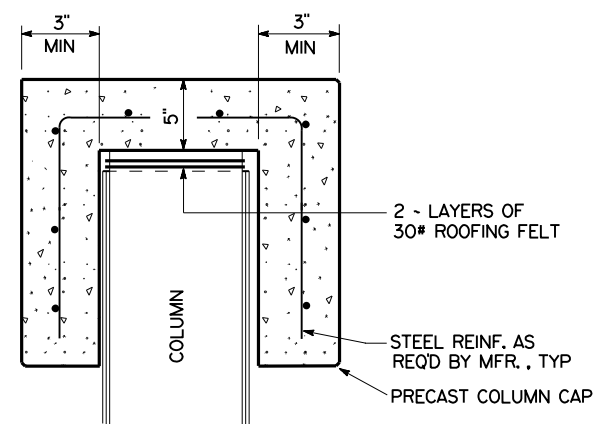
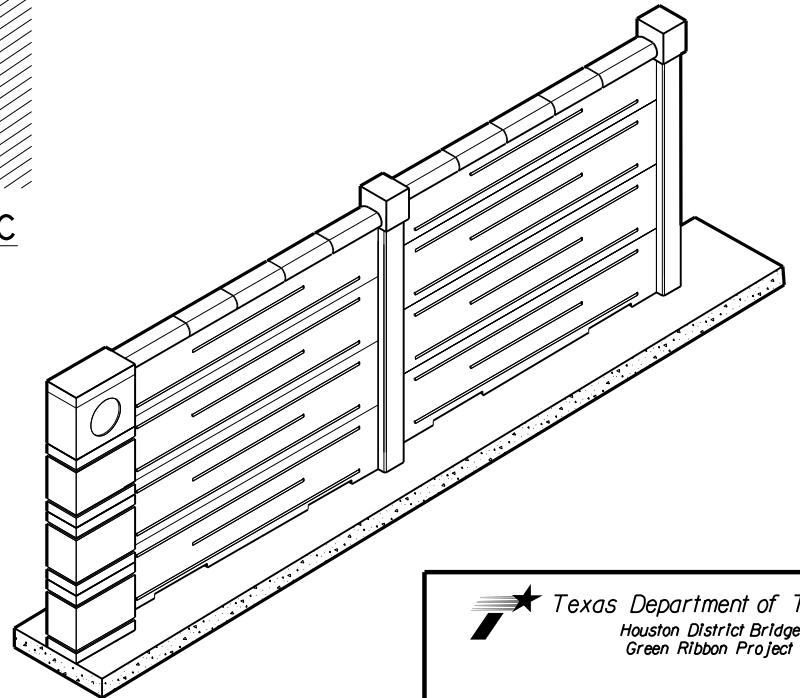

**SOUND WALL DETAILS**  
HORIZONTAL SCHEME

**SWD-HS**

FILE: STDJ6.DGN	DN: TxDOT	CK: TxDOT	DW: TxDOT	CK: TxDOT
© TxDOT DEC 2010	DISTRICT	FED REG	PROJECT NO.	SHEET
12/2010 Update bottom panel steel requirements.	HOUSTON	6		
8/2014 E-posed Aggregate removed current face added.	COUNTY	CONTROL	SECT	JOB
6/2017 Removed Minn'l Hand Bldg.				HIGHWAY