

SIGN	DIMENSIONS (INCHES)														
	SIZE	A	B	C	D	E	F	G	H	I	J	K	L	M	N
MIN	18	1-1/8	1-5/16	1-7/8	1-3/16	1	1-1/4	1-3/8	1-1/2	1-1/16	1-1/16	2-1/4	7-1/2	5-13/16	1-7/16
STD	24	1-1/2	1-3/4	2-9/16	1-5/8	1-3/8	1-11/16	1-7/8	2	1-7/16	1-7/16	3	10	7-3/4	1-15/16
SPECIAL	30	1-7/8	2-3/16	3-3/16	2	1-11/16	2-1/8	2-3/8	2-1/2	1-13/16	1-13/16	3-3/4	12-1/2	9-11/16	2-3/8
OH	36	2-1/4	2-5/8	3-13/16	2-7/16	2-11/16	2-1/2	2-13/16	3	2-1/8	2-1/8	4-1/2	15	11-5/8	2-7/8

SIGN	SIZE	A	B	C	D	E	F	G	H	I	J	K	L	M	N	O	P	R	S	T
		MIN	18	8-3/8	4-3/16	1-5/8	2-9/16	2-3/8	5/8	3/4	1/4	1/8	1-13/16	9/16	2	2-7/8	1/8	3/8	2-11/16	9
STD	24	11-3/16	5-5/8	2-3/16	3-3/8	3-3/16	13/16	1	5/16	3/16	2-3/8	1-1/8	2-5/8	3-13/16	7/8	3/8	3-5/8	12	R=15-13/16	4-1/4
SPECIAL	30	14	7	2-3/4	4-1/4	4	1	1-1/4	3/8	1/4	3	1-3/8	3-1/4	4-3/4	1-1/8	1/2	4-1/2	15	R=19	5-5/16
OH	36	16-3/4	8-3/8	3-1/4	5-1/4	4-3/8	1-3/16	1-1/2	1/2	5/8	3-5/8	1-5/8	4	5-3/4	1-3/8	3/8	5-3/8	18	R=22-3/4	5-7/8

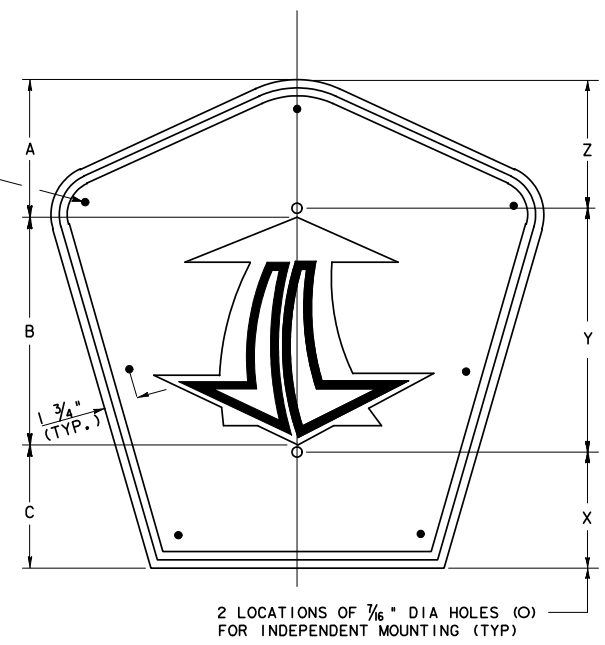
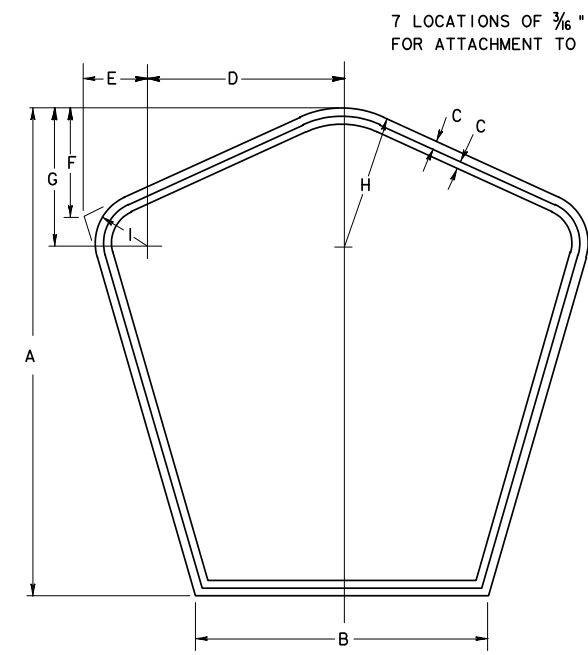
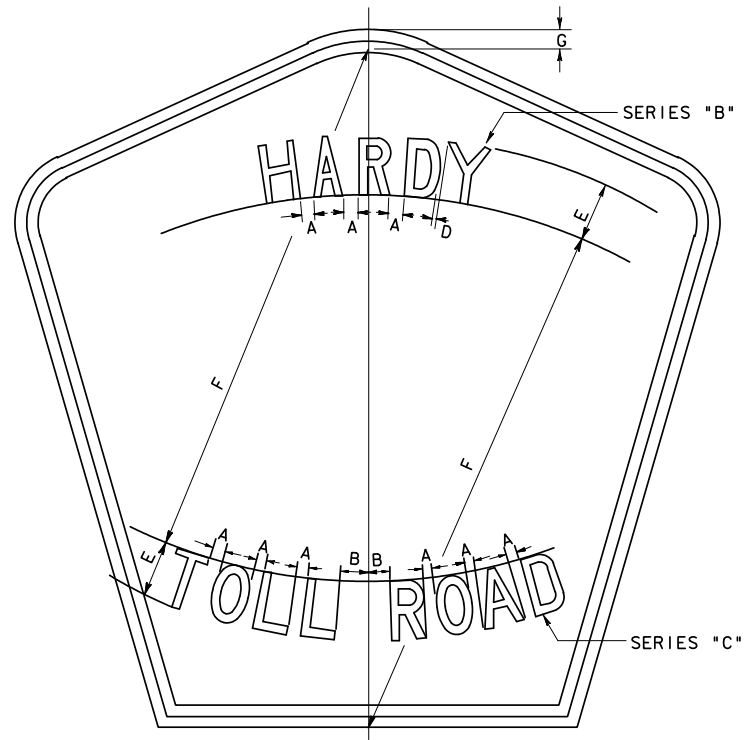

SIGN	SAM HOUSTON TOLLWAY	HARDY TOLL ROAD	WESTPARK TOLLWAY
TYPE	MI-5S	MI-5H	MI-5W
MIN	18x18	18x18	18x18
STD	24x24	24x24	24x24
SPECIAL	30x30	30x30	30x30
OH	36x36	36x36	36x36

- LETTERS - YELLOW REFLECTIVE
- INNER ARROW - YELLOW REFLECTIVE
- OUTER ARROW - YELLOW REFLECTIVE
- BORDER - YELLOW REFLECTIVE
- BACKGROUND - PURPLE REFLECTIVE
- INNER ARROW - PURPLE REFLECTIVE
- OUTLINE

THE PURPLE COLOR SHALL BE PANTONE 266.
THE YELLOW COLOR SHALL BE PANTONE 109.

FOR DEPARTMENT MATERIAL SPECIFICATIONS AND GENERAL NOTES SEE "TSR SERIES" STANDARD.

SIGN	DIMENSIONS (INCHES)							
	SIZE	A	B	C	D	E	F	G
MIN	18	5/16	5/8	7/8	1/8	1-1/2	13-13/16	1/16
STD	24	7/8	7/8	1-3/16	1/8	2	18-3/8	3/16
SPECIAL	30	1/2	1	1-1/2	3/16	2-1/2	23	3/4
OH	36	5/8	1-3/8	1-13/16	1/4	4-1/2	27	7/8

SIGN	DIMENSIONS (INCHES)									
	A	B	C	D	E	F	G	H	I	
MIN	18	10-5/8	1/4	7	2-3/8	3-3/8	5	5	2	
STD	24	14-3/16	3/8	9-5/16	3-1/8	5-1/8	6-5/8	5-5/16	2-11/16	
SPECIAL	30	17-3/4	1/2	11-5/8	3-7/8	6-1/2	8-1/4	6-5/8	3-3/8	
OH	36	21-1/4	5/8	14	4-3/4	6-3/4	10	10	4	

SIGN	DIMENSIONS (INCHES)			
	SIZE	A	B	C
MIN	18	5	8-3/8	4-5/8
STD	24	6-5/8	11-3/16	6-3/16
SPECIAL	30	8-1/4	14	7-3/4
OH	36	10	16-3/4	9-1/4

SIGN	DIMENSIONS (INCHES)		
	X	Y	Z
MIN	4-1/2	9-1/4	4-1/4
STD	6-1/4	12	5-3/4
SPECIAL	7-3/4	15	7-1/4
OH	9-3/8	18	8-5/8



TOLL ROAD ROUTE MARKERS (FOR ATTACHMENT TO GUIDE SIGNS AND INDEPENDENT MOUNTING)

TRM(1)-04

FILE#	DN#	CK#	DW#	CK#
© TxDOT 1998	DIST	FED REG	PROJECT NO.	SHEET
REVISIONS	HOU	6		
	COUNTY	CONTROL	SECT	JOB
				HIGHWAY