

NOTES:

1. CONCRETE SHALL BE CLASS "C" F'C = 3600 PSI.
2. ALL REINFORCING SHALL BE GRADE 60.
3. ALL DIMENSIONS OF THE REINFORCING BARS ARE TO ϕ OF BARS UNLESS OTHERWISE NOTED.
4. CHAMFER ALL EXPOSED CORNERS $\frac{3}{4}$ ".
5. ANGLE AND STUD ASSEMBLIES AND ALL STEEL HARDWARE, INCLUDING EMBEDDED CHORD ANGLES, STUDS & CONDUIT IN THE COLUMNS ARE INCIDENTAL TO ITEM 650 OVERHEAD SIGN SUPPORTS.
6. ALL STEEL HARDWARE SHALL BE GALVANIZED.
7. FORM LINER IS "FRACTURED GRANITE", MODEL NO. 110 BY SCOTT SYSTEMS, INC. OR EQUAL AS APPROVED BY ARCHITECT.
8. COMPONENTS OF THE STRUCTURE DESIGNED ACCORDING TO AASHTO LRFD BRIDGE DESIGN SPECIFICATIONS AND/OR AASHTO STANDARD SPECIFICATIONS FOR STRUCTURAL SUPPORTS FOR HIGHWAY SIGNS, LUMINAIRES, AND TRAFFIC SIGNALS.
9. EMBEDDED CHORD ANGLES, COMPLETE WITH STUDS & HOLES, SHALL BE PROVIDED BY THE TRUSS FABRICATOR.
10. CONTRACTOR SHALL BE RESPONSIBLE FOR DETERMINING & MAINTAINING LOCATION & ORIENTATION OF THE EMBEDDED ANGLES FOR TRUSS FIT-UP, CAMBER, & DEFLECTION. TEMPLATES MAY BE NEEDED TO HOLD THE ANGLES IN PLACE. (NO DIRECT PAY)
11. IF SINGLE SHEAR SPLICES CONFLICT WITH THE GUSSET PLATES, THEN USE DOUBLE SHEAR SPLICES.
12. WELD STUDS TO ANGLE FLANGES IN ACCORDANCE WITH AWS D1.5.
13. FOR CANTILEVER TRUSS LENGTHS FALLING BETWEEN THOSE SHOWN USE SIZES CALLED FOR IN THE NEXT LONGER SPAN.
14. CONCRETE COLUMNS ARE DESIGNED FOR THE EQUIVALENT AREA OF A 12'-6" DEEP SIGN PANEL OVER 100% OF THE SPAN LENGTH. DESIGN INCLUDES 3 POUNDS PER FOOT SQUARED FOR SIGN PANEL AND 20 POUNDS PER FOOT FOR LIGHTS AND 50 POUNDS PER FOOT FOR WALKWAYS OVER 100% OF THE SPAN LENGTH.



CANTILEVER OVERHEAD SIGN STRUCTURE DETAILS VERTICAL SCHEME

COSS-VS

FILE#	STDN41.DGN	DN#	HOU	CK#	HOU	DW#	HOU	CK#	HOU
©	TxDOT	AUGUST 2011	DISTRICT	FED REG	HOUSTON	6	PROJECT NO.		SHEET
REVISIONS							COUNTY	CONTROL	SECT
									JOB
									HIGHWAY

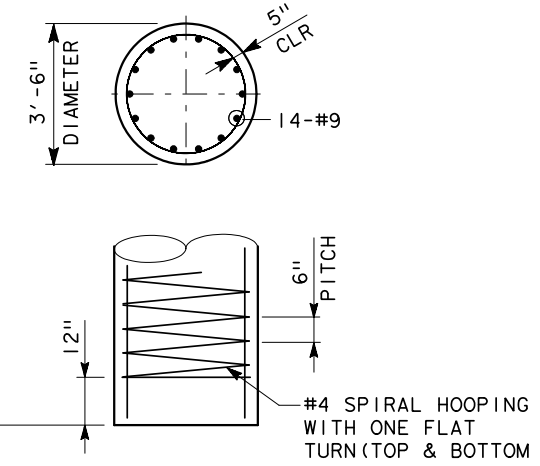
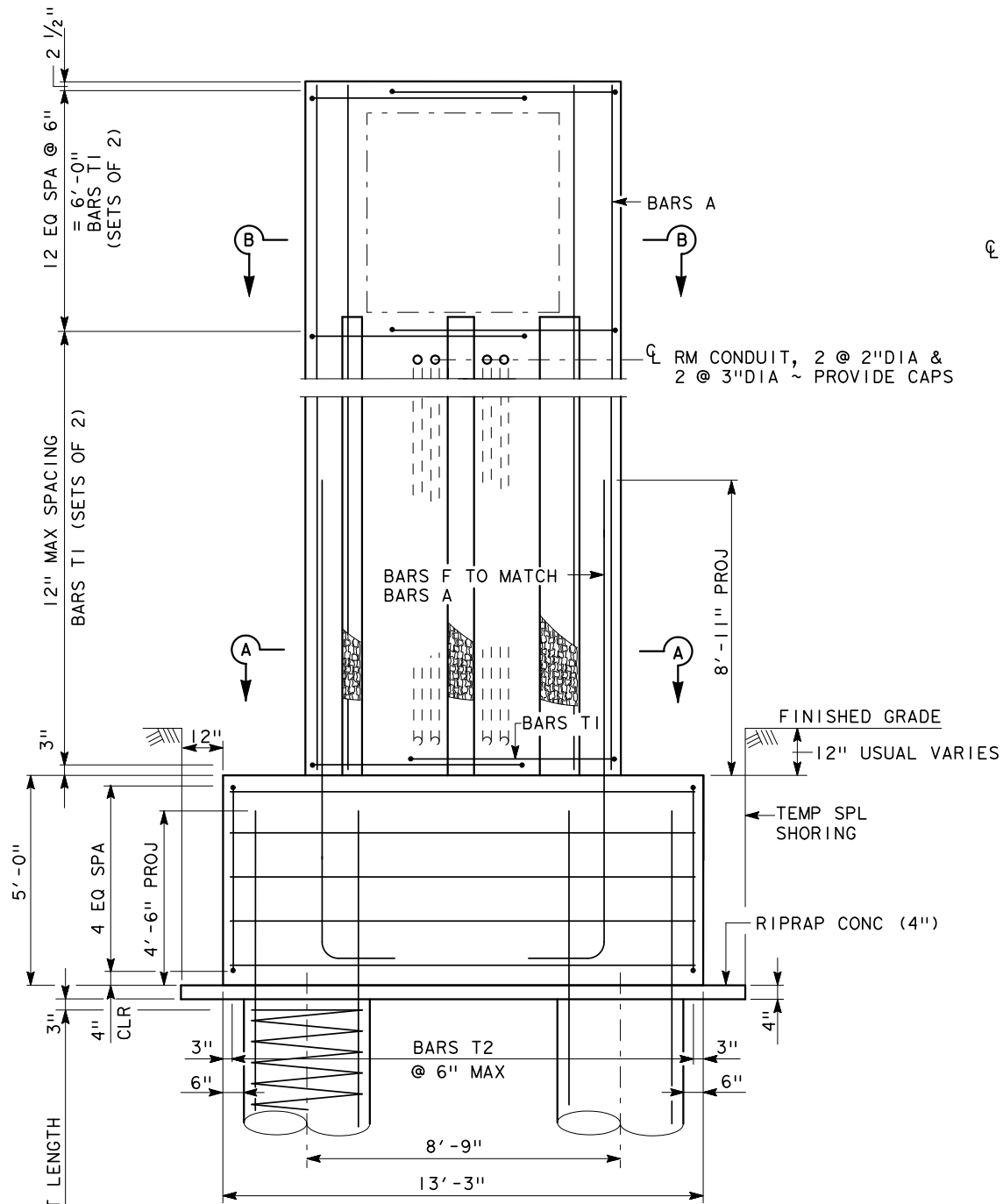

FRONT ELEVATION

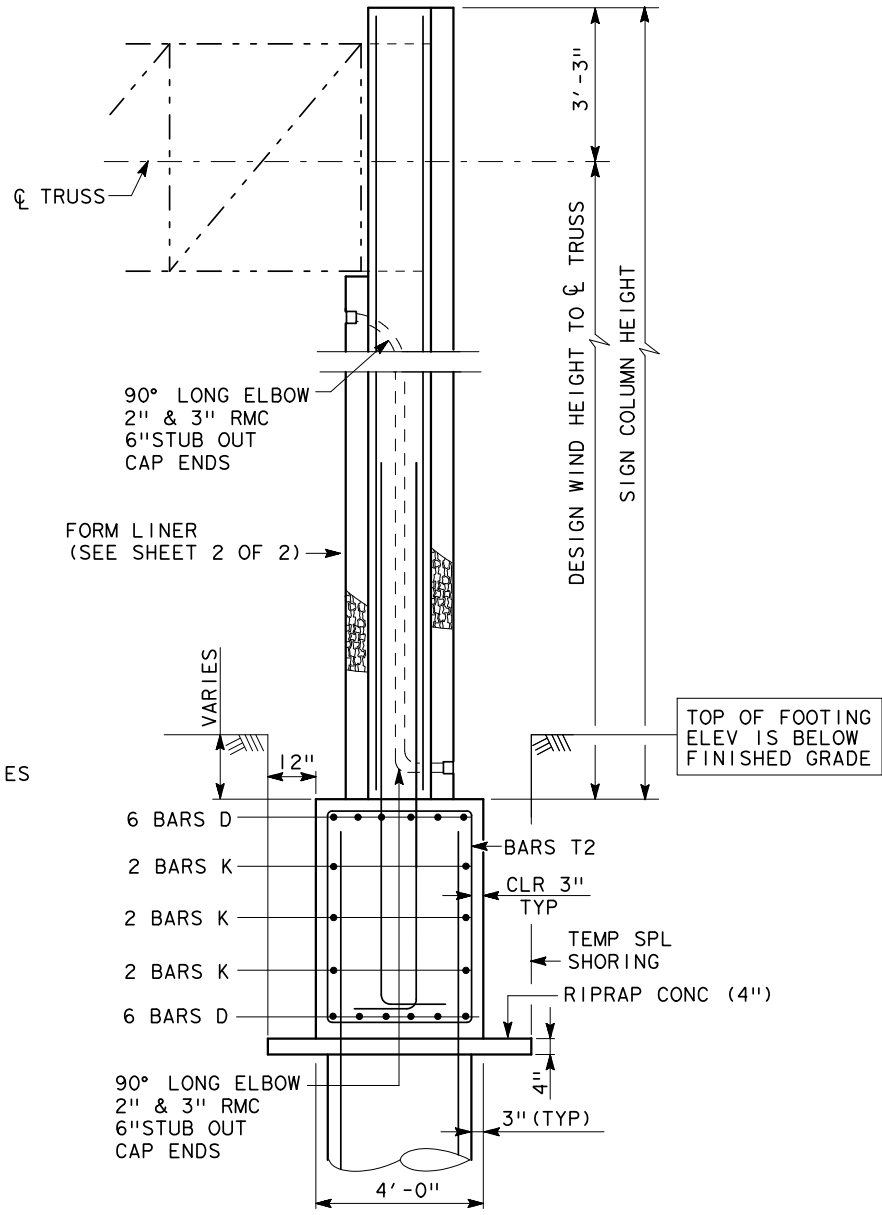

SIDE ELEVATION

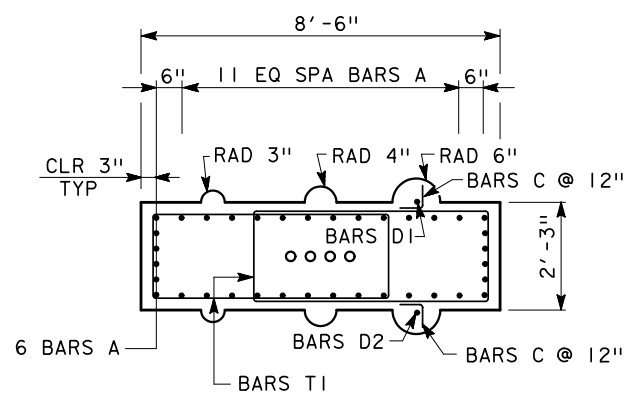

SECTION A-A

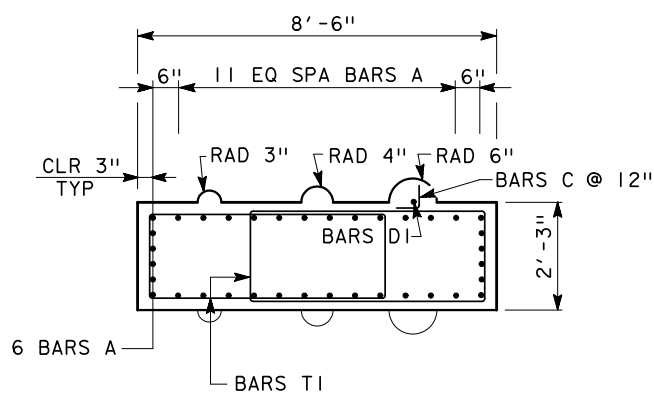

SECTION B-B