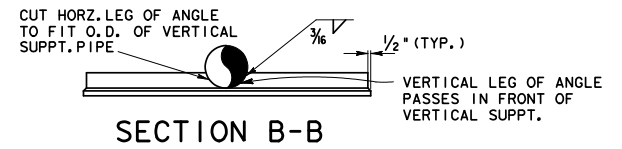
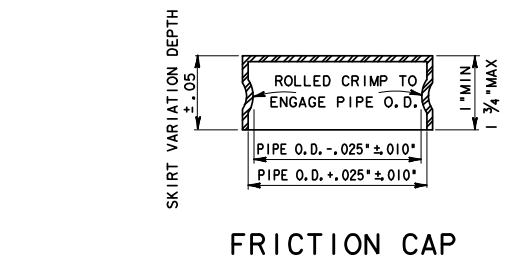

TABLE OF PIPE SIZES			
SIGN AREA S.F.	PIPE A SIZE	PIPE B SIZE	CORRESPONDING TYPE GROUND MOUNT
1-10	4.500\"/>		
10-16	8.625\"/>		
16-32	8.625\"/>		
32-40	8.625\"/>		



BRIDGE MOUNTED SIGNS



NOTES:
 FRICTION CAPS-MANUFACTURED FROM HOT OR COLD ROLLED STEEL SHEETS, SIZED FOR DRIVE FRICTION FIT, AND SO FORMED AS TO HAVE NO TENDENCY TO ROCK WHEN SEATED. THEY SHALL BE FREE OF SHARP INDENTATIONS AND EVIDENCE OF METAL FRACTURE, WITH RIMS REASONABLY STRAIGHT AND SMOOTH.

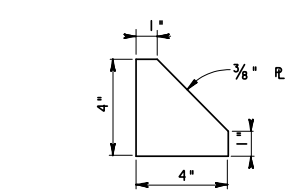

3/8\"/>

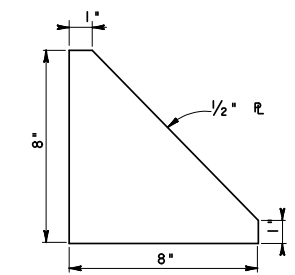

1/2\"/>

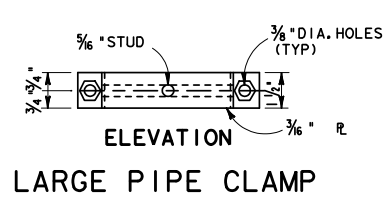
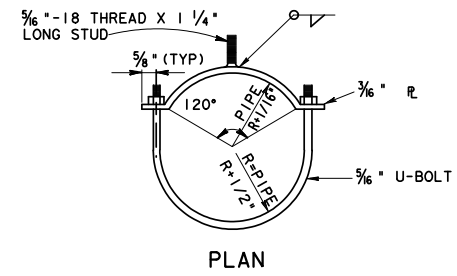

LARGE PIPE CLAMP

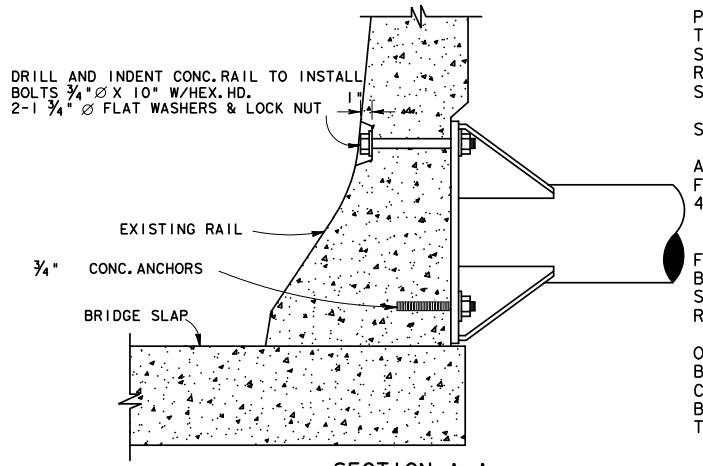

SECTION A-A (SHOWING EXISTING RAILING)

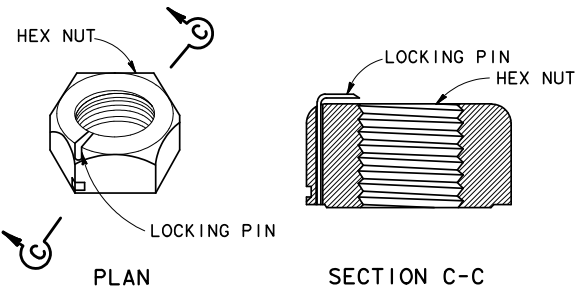

LOCK NUT DETAIL

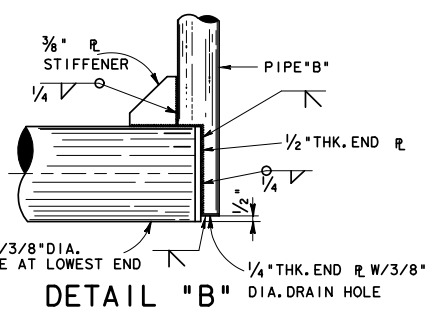

DETAIL "B"

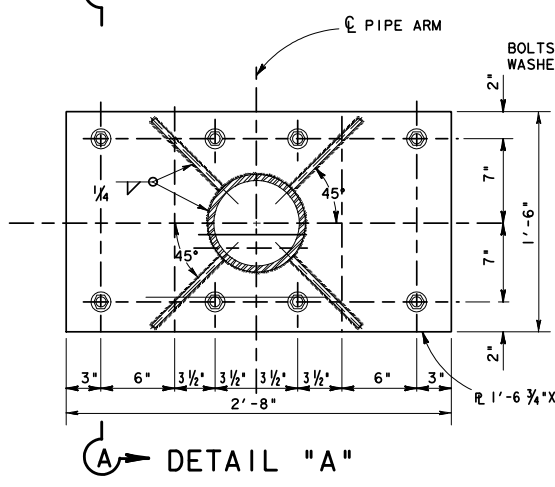

DETAIL "A"

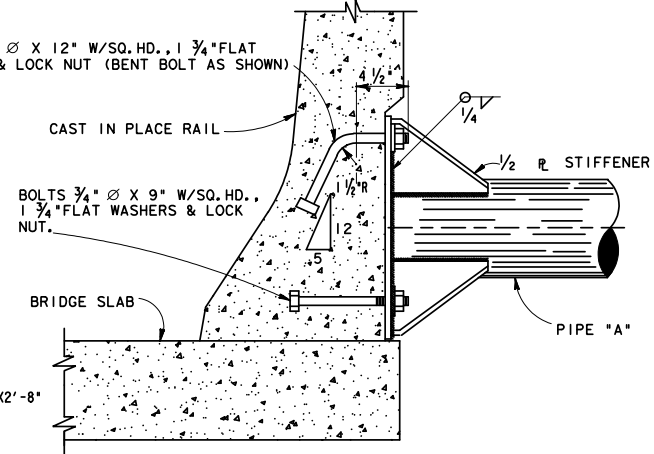

SECTION A-A (SHOWING CAST IN PLACE RAIL)

NOTES:

CONTRACTOR SHALL CHECK CROSS SLOPE ON BRIDGES AND THEN FABRICATE SIGN MOUNTS SO SIGN SUPPORT PIPE IS VERTICAL. ADDITIONAL "U" OR "T" EXTENSION PIPE OF THE SIZE AND LENGTHS SHOWN ON STANDARD PLAN SHEETS SHALL BE PROVIDED AND ATTACHED (WELDED OR AS DIRECTED BY THE ENGINEER) TO PIPE "B" AS REQUIRED. SIGN PANELS SHALL BE ATTACHED TO THE 3" DIA. OR SMALLER PIPE ARMS AS SHOWN IN THE STANDARD PLAN SHEETS. ATTACHMENT TO 4" OR 6" PIPES SHALL BE AS SHOWN ON THIS SHEET OR AS SHOWN IN STANDARD PLAN SHEETS EXCEPT FOR R2-1 AND R2-4 OR R5-1A AND R5-1 SIGN COMBINATIONS WHICH SHALL BE MOUNTED AS SHOWN ON THIS SHEET. LOCK NUTS WITH NONREVERSIBLE HIGH TENSILE STRENGTH STAINLESS STEEL LOCKING PINS SHALL BE USED ON BOLTS. CONCRETE ANCHORS SHALL BE STANDARD 3 UNIT CONCRETE ANCHORS. RAWL, PARABOLT, KWIKBOLT OR EQUAL, WITH LOCK NUT, FLAT WASHER & LOCK WASHER. ANCHORS SHALL NOT BE LESS THAN 4 1/2" IN LENGTH. SIGN SUPPORTS SHALL BE GALVANIZED AFTER FABRICATION. SIGN SUPPORT BRACKETS AS DETAILED ON THIS SHEET ARE FOR SIGNS MOUNTED ON RIGHT SIDE OF ROADWAY. LEFT HAND BRACKETS SHALL BE OPPOSITE TO THOSE SHOWN. SEE SIGN LAYOUT SHEETS TO DETERMINE WHETHER RIGHT OR LEFT HAND BRACKET IS REQUIRED. ANY CHIPPING, GOUGING, OR OTHER WORK, TOOLS OR ANY OTHER INCIDENTALS NECESSARY TO EFFECT THE INSTALLATION OF BRIDGE MOUNTED SIGN BRACKETS ON CURBS, PARAPET WALLS, COPINGS OR OTHER LOCATIONS AS CALLED FOR IN PLANS WILL NOT BE PAID FOR DIRECTLY BUT SHALL BE CONSIDERED SUBSIDIARY TO THE ITEM "SMALL ROADSIDE SIGN SUPPORTS AND ASSEMBLIES".



BRIDGE MOUNTING DETAILS (FOR SMALL ROADSIDE SIGNS)

SMD (BM-1) -04

FILE#	DN#	CK#	DW#	CK#
© TxDOT 1998	DIST	FED REG	PROJECT NO.	SHEET
REVISIONS	HOU	6	COUNTY	CONTROL SECT JOB HIGHWAY