

DISCLAIMER: This standard is governed by the "Texas Engineering Practice Act". No warranty of any kind is made by TxDOT for any purpose whatsoever. TxDOT assumes no responsibility for the conversion of this standard to other formats or for incorrect results or damages resulting from its use.

DATE:  
FILE:

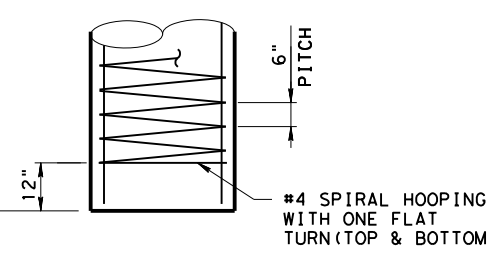

FRONT ELEVATION

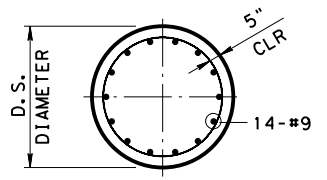
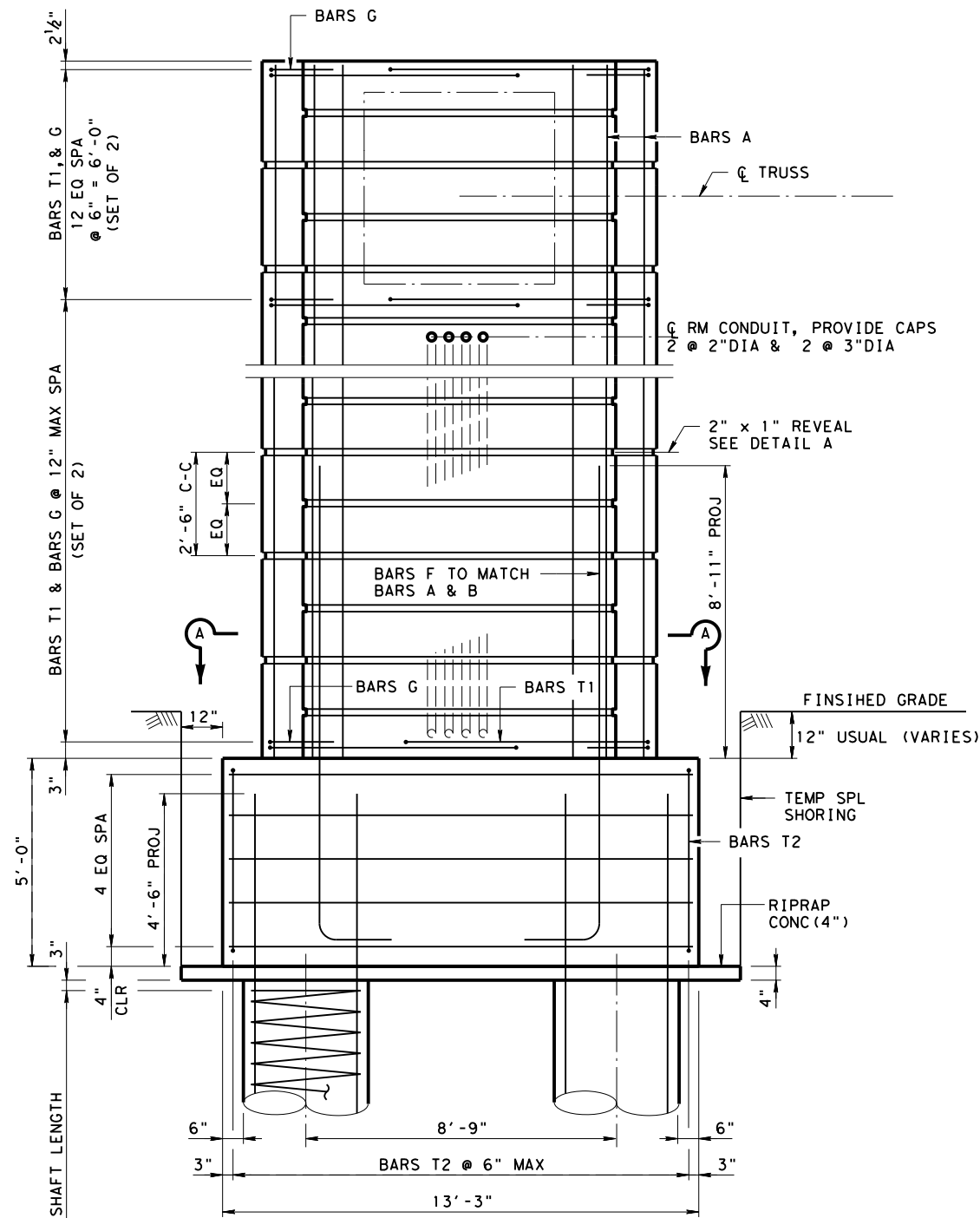
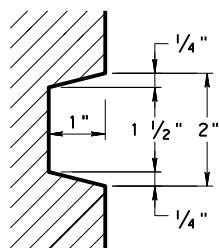

DETAIL A

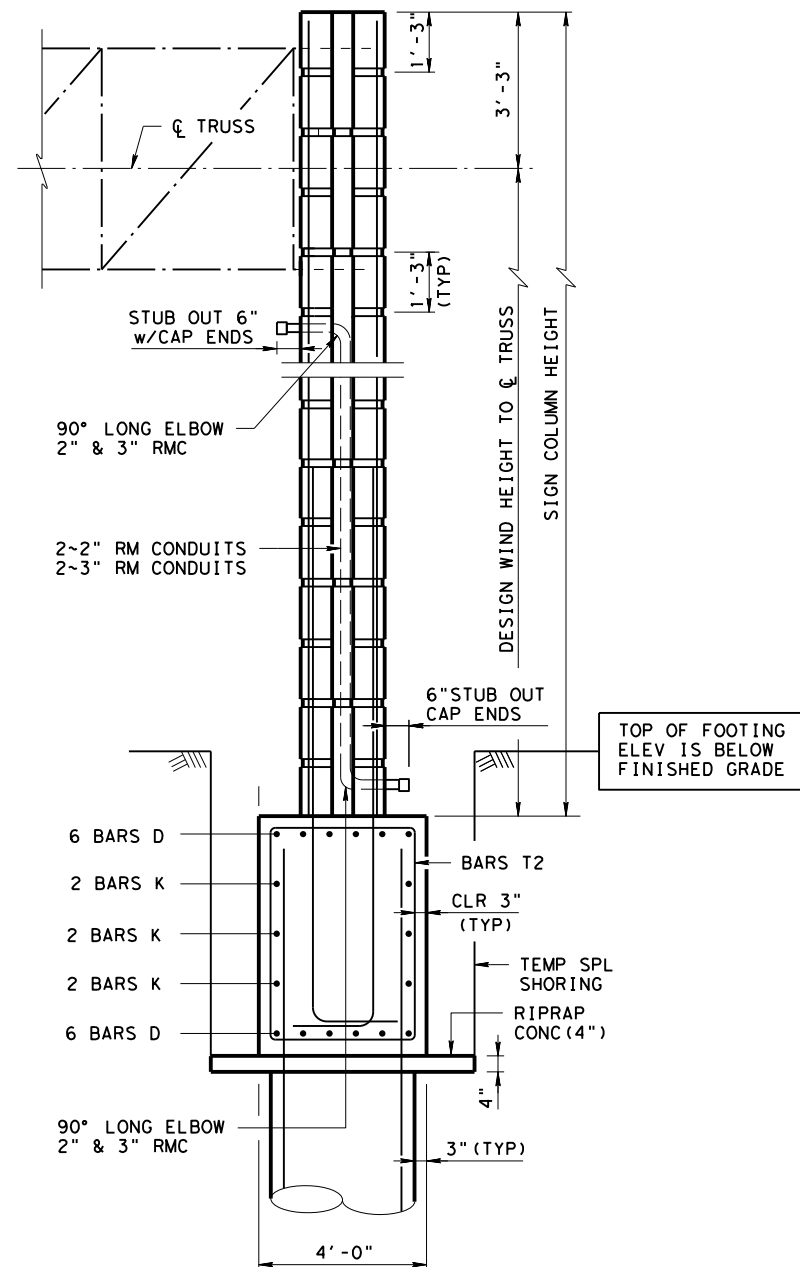

SIDE ELEVATION

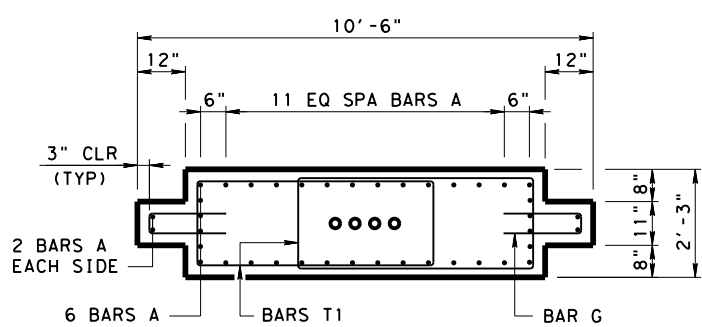

SECTION A-A

- GENERAL NOTES:**
1. CONCRETE SHALL BE CLASS "C" F' C = 3600 psi.
  2. ALL REINFORCING SHALL BE ASTM A615 GRADE 60.
  3. ALL DIMENSIONS OF THE REINFORCING BARS ARE TO  $\phi$  OF BARS UNLESS OTHERWISE NOTED.
  4. CHAMFER ALL EXPOSED CORNERS  $\frac{3}{4}$ ".
  5. ANCHOR BOLT ASSEMBLIES AND ALL STEEL HARDWARE, INCLUDING CONDUIT IN THE COLUMNS ARE INCIDENTAL TO ITEM 650 OVERHEAD SIGN SUPPORTS.
  6. ALL STEEL HARDWARE SHALL BE GALVANIZED.
  7. COMPONENTS OF THE STRUCTURE DESIGNED ACCORDING TO AASHTO LRFD BRIDGE DESIGN SPECIFICATIONS AND/OR AASHTO STANDARD SPECIFICATIONS FOR STRUCTURAL SUPPORTS FOR HIGHWAY SIGNS, LUMINAIRES, AND TRAFFIC SIGNALS.
  8. EMBEDDED CHORD ANGLES, COMPLETE WITH STUDS & HOLES, SHALL BE PROVIDED BY THE TRUSS FABRICATOR.
  9. CONTRACTOR SHALL BE RESPONSIBLE FOR DETERMINING & MAINTAINING LOCATION & ORIENTATION OF THE EMBEDDED ANGLES FOR TRUSS FIT-UP, CAMBER, & DEFLECTION. TEMPLATES MAY BE NEEDED TO HOLD THE ANGLES IN PLACE. (NO DIRECT PAY)
  10. IF SINGLE SHEAR SPLICES CONFLICT WITH THE GUSSET PLATES, THEN USE DOUBLE SHEAR SPLICES.
  11. WELD STUDS TO ANGLE FLANGES IN ACCORDANCE WITH AWS D1.5.
  12. FOR CANTILEVER TRUSS LENGTHS FALLING BETWEEN THOSE SHOWN USE SIZES CALLED FOR IN THE NEXT LONGER SPAN.
  13. CONCRETE COLUMNS ARE DESIGNED FOR THE EQUIVALENT AREA OF A 12'-6" DEEP SIGN PANEL OVER 100% OF THE SPAN LENGTH. DESIGN INCLUDES 3 POUNDS PER FOOT SQUARED FOR SIGN PANEL AND 20 POUNDS PER FOOT FOR LIGHTS AND 50 POUNDS PER FOOT FOR WALKWAYS OVER 100% OF THE SPAN LENGTH.

**CANTILEVER OVERHEAD SIGN STRUCTURE DETAILS**  
HORIZONTAL SCHEME

COSS-HS-25 (HOU)

FILE: COSS-HS-25 (HOU).DGN	DN: TXDOT	CK: TXDOT	DW: TXDOT	CK: TXDOT
© TXDOT April 2025	CONT	SECT	JOB	HIGHWAY
REVISIONS				
03/2025: 2024 Spec Updates	DIST	COUNTY	SHEET NO.	
	HOU			

DISCLAIMER: This standard is governed by the "Texas Engineering Practice Act". No warranty of any kind is made by TxDOT for any purpose whatsoever. TxDOT assumes no responsibility for the conversion of this standard to other formats or for incorrect results or damages resulting from its use.

DATE:  
FILE:

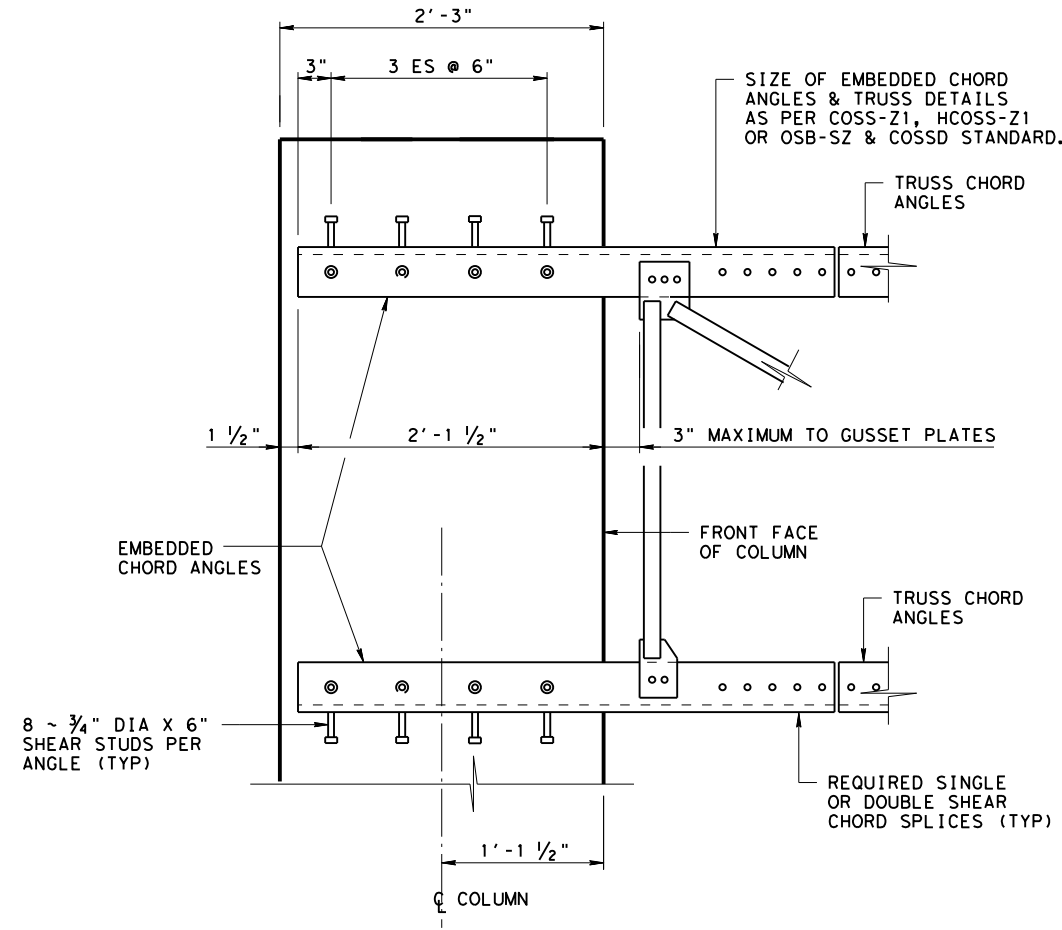

**SECTION THRU EMBEDDED TRUSS**

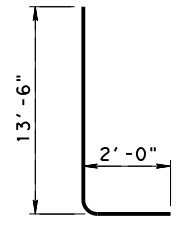

**BAR F (#11)**

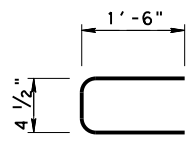

**BAR G (#4)**

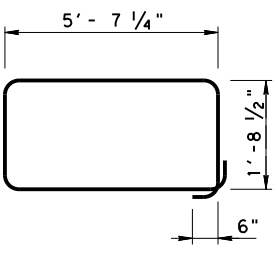

**BAR T1 (#5)**

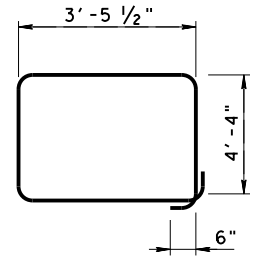

**BAR T2 (#5)**

TABLE OF ESTIMATED COLUMN QUANTITIES (FOR ONE COLUMN)				
4.5' x 4.5' TRUSS				
BARS	NO.	SIZE	LENGTH	WEIGHT
A	40	#11	29'-10"	6,340
D	12	#11	12'-11"	824
F	40	#11	15'-6"	3,294
G	74	#4	3'-4 1/2"	167
K	6	#6	12'-11"	116
T1	74	#5	15'-7 1/2"	1,206
T2	27	#5	16'-7"	467
REINFORCING STEEL			LBS	12,414
TEMPORARY SPECIAL SHORING			SF	269
CL C CONC (SIGN FOOTING)			CY	9.8
CL C CONC (SIGN COLUMN)			CY	23.3
RIPRAP CONC (4 IN)			CY	1.0

① QUANTITIES SHOWN ARE BASED ON A SIGN COLUMN HEIGHT OF 30'. FOR EACH LINEAR FOOT VARIATION IN HEIGHT MAKE THE FOLLOWING ADJUSTMENTS:  
 BARS A LENGTH, 1'-0"  
 REINFORCING STEEL, 250 LB  
 CL C CONC (SIGN COLUMN), 0.78 CY.

Texas Department of Transportation

Bridge  
Houston  
District  
Standard

## CANTILEVER OVERHEAD SIGN STRUCTURE DETAILS HORIZONTAL SCHEME

### COSS-HS-25 (HOU)

FILE: COSS-HS-25 (HOU).DGN	DN: TXDOT	CK: TXDOT	DW: TXDOT	CR: TXDOT
© TXDOT April 2025	CONT	SECT	JOB	HIGHWAY
REVISIONS				
04/2025: 2024 Spec Updates	DIST	COUNTY	SHEET NO.	
	HOU			

DISCLAIMER: The use of this standard is governed by the "Texas Engineering Practice Act". No warranty of any kind is made by TxDOT for any purpose whatsoever. TxDOT assumes no responsibility for the conversion of this standard to other formats or for incorrect results or damages resulting from its use.

SPAN (ft)	DESIGN WIND HEIGHT TO $\phi$ TRUSS (ft)	MAXIMUM DRILLED SHAFT AXIAL LOAD (kips)	MAXIMUM DRILLED SHAFT MOMENT (k-ft)	DRILLED SHAFT EMBEDMENT LENGTH (ft)			
				AVERAGE N (BLOWS/12") (SEE NOTE 8)			
				10	20	30	40
10	15	62	73	19	14	14	14
	20	75	114	23	14	14	14
	25	89	165	26	17	17	17
	30	103	227	30	20	20	20
	35	118	299	34	23	23	23
	40	134	383	38	27	27	27
	45	150	478	42	30	30	30
	50	167	585	46	33	33	33
15	15	69	79	21	14	14	14
	20	83	119	25	14	14	14
	25	99	171	29	17	17	17
	30	115	232	33	20	20	20
	35	132	305	37	23	23	23
	40	150	388	42	27	27	27
	45	168	483	47	30	30	30
	50	187	590	52	33	33	33
20	15	74	86	22	14	14	14
	20	91	127	27	15	14	14
	25	108	178	31	17	17	17
	30	126	240	36	20	20	20
	35	145	312	41	23	23	23
	40	164	396	46	27	27	27
	45	185	491	51	30	30	30
	50	206	598	57	33	33	33
25	15	80	96	24	14	14	14
	20	98	136	28	16	14	14
	25	117	188	33	18	17	17
	30	137	249	39	21	20	20
	35	158	322	44	24	23	23
	40	180	405	50	27	27	27
	45	202	500	55	30	30	30
	50	225	607	62	33	33	33
30	15	85	107	25	14	14	14
	20	105	148	30	17	14	14
	25	126	199	36	19	17	17
	30	148	261	41	22	20	20
	35	171	333	47	25	23	23
	40	194	417	53	28	27	27
	45	219	512	60	31	30	30
	50	244	619	66	35	33	33
55	270	737	73	38	37	37	

SPAN (ft)	DESIGN WIND HEIGHT TO $\phi$ TRUSS (ft)	MAXIMUM DRILLED SHAFT AXIAL LOAD (kips)	MAXIMUM DRILLED SHAFT MOMENT (k-ft)	DRILLED SHAFT EMBEDMENT LENGTH (ft)			
				AVERAGE N (BLOWS/12") (SEE NOTE 8)			
				10	20	30	40
35	15	91	121	27	15	14	14
	20	113	162	32	18	14	14
	25	135	213	38	21	17	17
	30	159	275	44	24	20	20
	35	183	347	51	27	23	23
	40	209	431	57	30	27	27
	45	235	526	64	34	30	30
	50	262	633	71	37	33	33
40	15	96	137	28	16	14	14
	20	120	178	34	19	14	14
	25	144	229	40	22	17	17
	30	170	291	47	25	20	20
	35	196	363	54	28	23	23
	40	224	447	61	32	27	27
	45	252	542	68	36	30	30
	50	281	649	76	40	33	33
45	15	102	155	30	16	14	14
	20	127	196	36	20	14	14
	25	153	247	43	23	17	17
	30	181	309	50	26	20	20
	35	209	381	57	30	23	23
	40	238	465	65	34	27	27
	45	268	560	73	38	30	30
	50	300	667	81	42	33	33
55	332	785	89	46	37	37	

1. DETERMINE DRILLED SHAFT DIAMETER AND MAXIMUM DRILLED SHAFT AXIAL LOAD (KIPS) FROM TABLE BASED ON SPAN LENGTH AND DESIGN WIND HEIGHT TO CENTERLINE OF TRUSS.
2. CONTACT THE HOUSTON DISTRICT LABORATORY FOR CONCISE DRILLED SHAFT EMBEDMENT LENGTH OR USE THE FOLLOWING ITERATIVE PROCEDURE.
3. MAKE AN INITIAL ESTIMATE OF THE DRILLED SHAFT EMBEDMENT LENGTH.
4. FROM SOIL EXPLORATION DATA, DETERMINE AN AVERAGE N VALUE (BLOWS/12") OF THE SOIL THROUGHOUT THE INITIAL EMBEDMENT LENGTH. USE A WEIGHTED-AVERAGE OF THE BLOW COUNT OF INDIVIDUAL STRATA.
5. USE TABLE TO DETERMINE THE REQUIRED DRILLED SHAFT EMBEDMENT LENGTH BASED ON AXIAL LOAD AND AVERAGE N.
6. IF THE REQUIRED EMBEDMENT LENGTH DIFFERS SIGNIFICANTLY FROM THE INITIAL ESTIMATED EMBEDMENT LENGTH, RETURN TO STEP 3 WITH THE REQUIRED EMBEDMENT LENGTH DETERMINED IN STEP 5 AND REPEAT STEPS 3, 4 & 5.
7. THE EMBEDMENT LENGTH TABLE IS BASED UPON THE GREATEST EMBEDMENT LENGTH DERIVED FROM MOMENT, UPLIFT, OR THE AXIAL LOAD IN THE DRILLED SHAFT.
8. TCP N-VALUE, REFER TO APPENDIX 2, TXDOT GEOTECHNICAL MANUAL-LRFD, APRIL 2024 FOR SPT N-VALUES AND TCP BLOW COUNTS CONVERSION

DESIGNER NOTE:  
THIS SHEET IS FOR DESIGNER'S USE  
IN DETERMINING DRILLED SHAFT DIAMETER,  
LOADS AND EMBEDMENT. DO NOT INSERT  
INTO PLANSET.

**FOUNDATION DATA AND EMBEDMENT LENGTH TABLE**  
(42" DIAMETER DRILLED SHAFT FOR ALL CASES)

 Texas Department of Transportation	<i>Bridge Houston District Standard</i>			
<b>CANTILEVER OVERHEAD SIGN STRUCTURE FOUNDATION DATA AND EMBEDMENT SELECTION TABLE HORIZONTAL SCHEME COSS-HS-25 (HOU)</b>				
FILE: COSS-HS-25 (HOU).DGN	DN: TXDOT	CK: TXDOT	DW: TXDOT	CR: TXDOT
© TXDOT April 2025	CONT	SECT	JOB	HIGHWAY
<b>REVISIONS</b>				
04/2025: 2024 Spec Updates Added Note 8	DIST	COUNTY	SHEET NO.	
	HOU			

DATE:  
FILE: