



# PAVED

Projects Adding Value by Expanding Diversity

Civil Rights Division





CIVIL RIGHTS DIVISION

## Texas Department of Transportation **PAVED** Transportation Summit

**Tyler Rose Garden Center - Camellia Room**  
**420 Rose Park Drive, Tyler, TX 75702**  
**Wednesday, May 10, 2017 - 3:30 PM - 6:00 PM**

- 
- |                   |  |
|-------------------|--|
| 3:30 PM – 4:00 PM | Registration   Check-in  |
| 4:00 PM – 4:20 PM | Welcome and Introductions  |
| 4:20 PM – 5:00 PM | Highway and Capital Project Presentations<br><i>TxDOT Projects: FM 1652 and SH 243</i><br><br><i>UT System Project: UT Health Northeast School of Community and Rural Health</i> |
| 5:00 PM – 6:00 PM | Prime and Subcontractor Round Table  |



THE UNIVERSITY OF TEXAS SYSTEM  
Office of HUB Programs



# Host Partners

Thank you to the following host partners:

## Regional Hispanic Contractors Association (RHCA)

John Martinez

President

[John@regionalhca.org](mailto:John@regionalhca.org)

Ruben Landa

Senior Communications Manager

[Ruben.Landa@wsp.com](mailto:Ruben.Landa@wsp.com)



## Regional Black Contractors Association (RBCA)

John Proctor

President

[johnproctor01@aol.com](mailto:johnproctor01@aol.com)



## University of Texas System

Christi Johnson

Senior HUB Coordinator

[cjohnson@utsystem.edu](mailto:cjohnson@utsystem.edu)



THE UNIVERSITY of TEXAS SYSTEM  
Office of HUB Programs

PAVED  
Projects Adding Value by Expanding Diversity

# Presenters and Participants

Thank you to the following speakers and panelists:

## Texas Department of Transportation

Paul Schneider, P.E.,  
Area Engineer, TxDOT Mineola Tyler District  
[Paul.Schneider@txdot.gov](mailto:Paul.Schneider@txdot.gov)

Michael Bryant  
Director – Office of Civil Rights  
[Michael.D.Bryant@txdot.gov](mailto:Michael.D.Bryant@txdot.gov)

Don Barwick, Ph.D.  
Program Specialist  
[Don.Barwick@txdot.gov](mailto:Don.Barwick@txdot.gov)

Sarah C. Blackburn, CTCM  
Special Projects Coordinator  
[Sarah.Blackburn@txdot.gov](mailto:Sarah.Blackburn@txdot.gov)

## University of Texas System

Christi Johnson  
Senior HUB Coordinator  
[cjohnson@utsystem.edu](mailto:cjohnson@utsystem.edu)

Rex Brown  
Resident Construction Manager  
[rbrown@utsystem.edu](mailto:rbrown@utsystem.edu)



# SH 243 AND FM 1652 WIDENING PROJECTS





# Project Locations

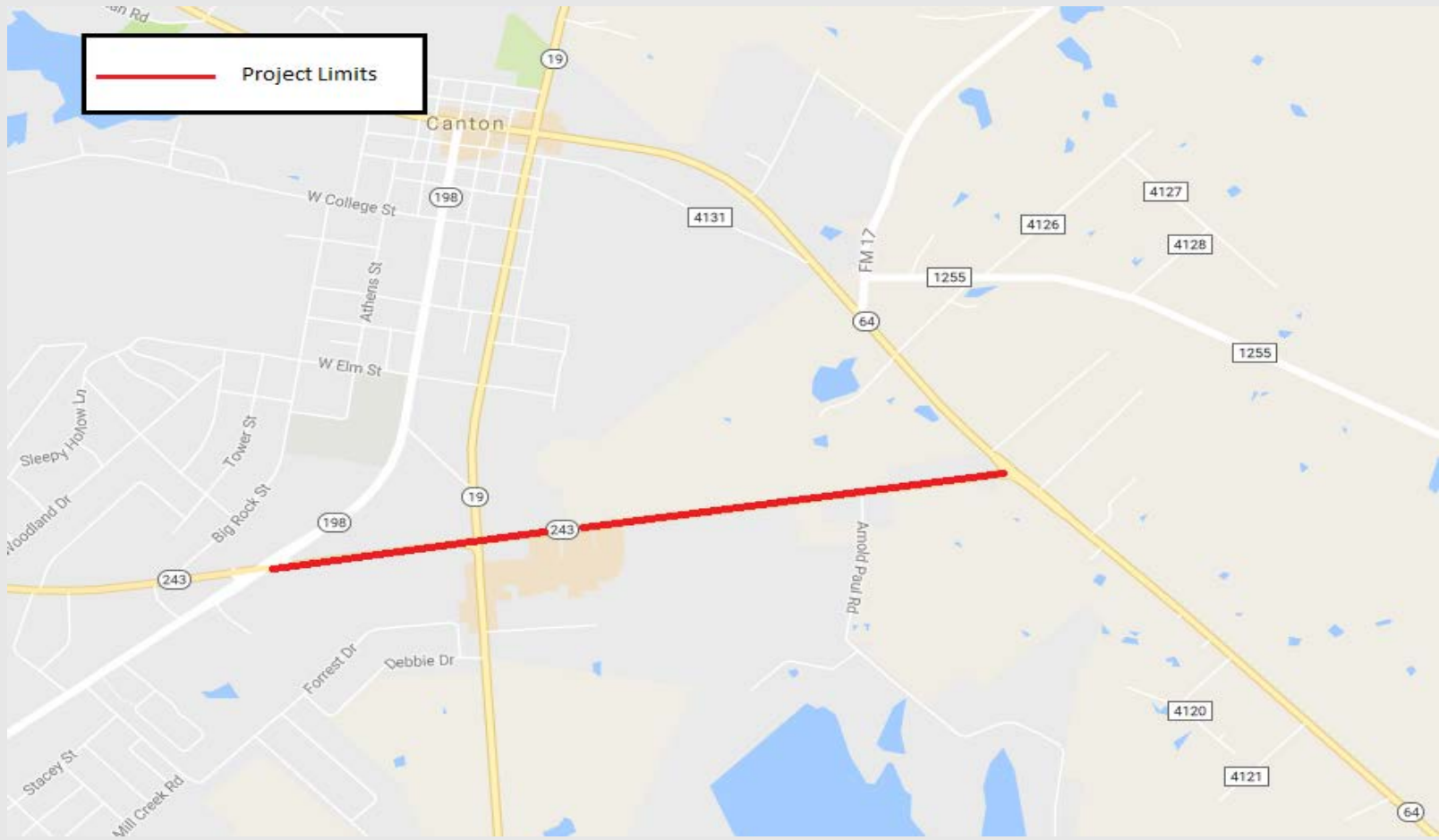

- **Widening SH 243**
- **Project Limits: SH 64 to SH 198**
- **Project Scope:**
  - Widen existing roadway to 4 lanes with a two-way left turn lane
  - Install curb and gutter
  - Install storm sewer system
  - Install ADA curb ramps and sidewalks
- **Project Goals:**
  - Manage congestion by increasing roadway capacity
  - Increase driver safety by increasing the number of travel lanes, revising signal timing, and managing off-ROW access
  - Increase pedestrian safety with new ADA facilities and 14' shared use outside lanes

## Existing Typical Sections

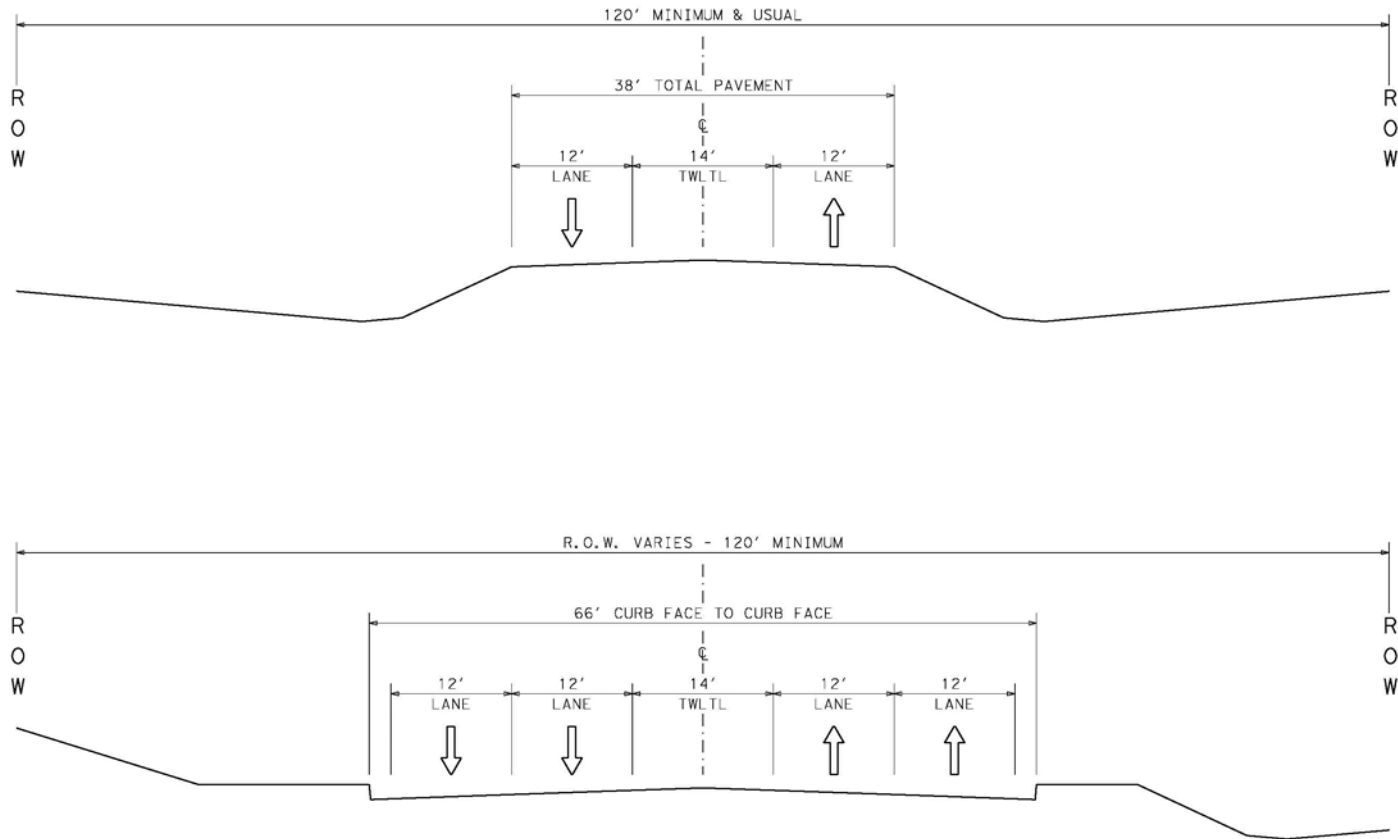



## Proposed Typical Sections

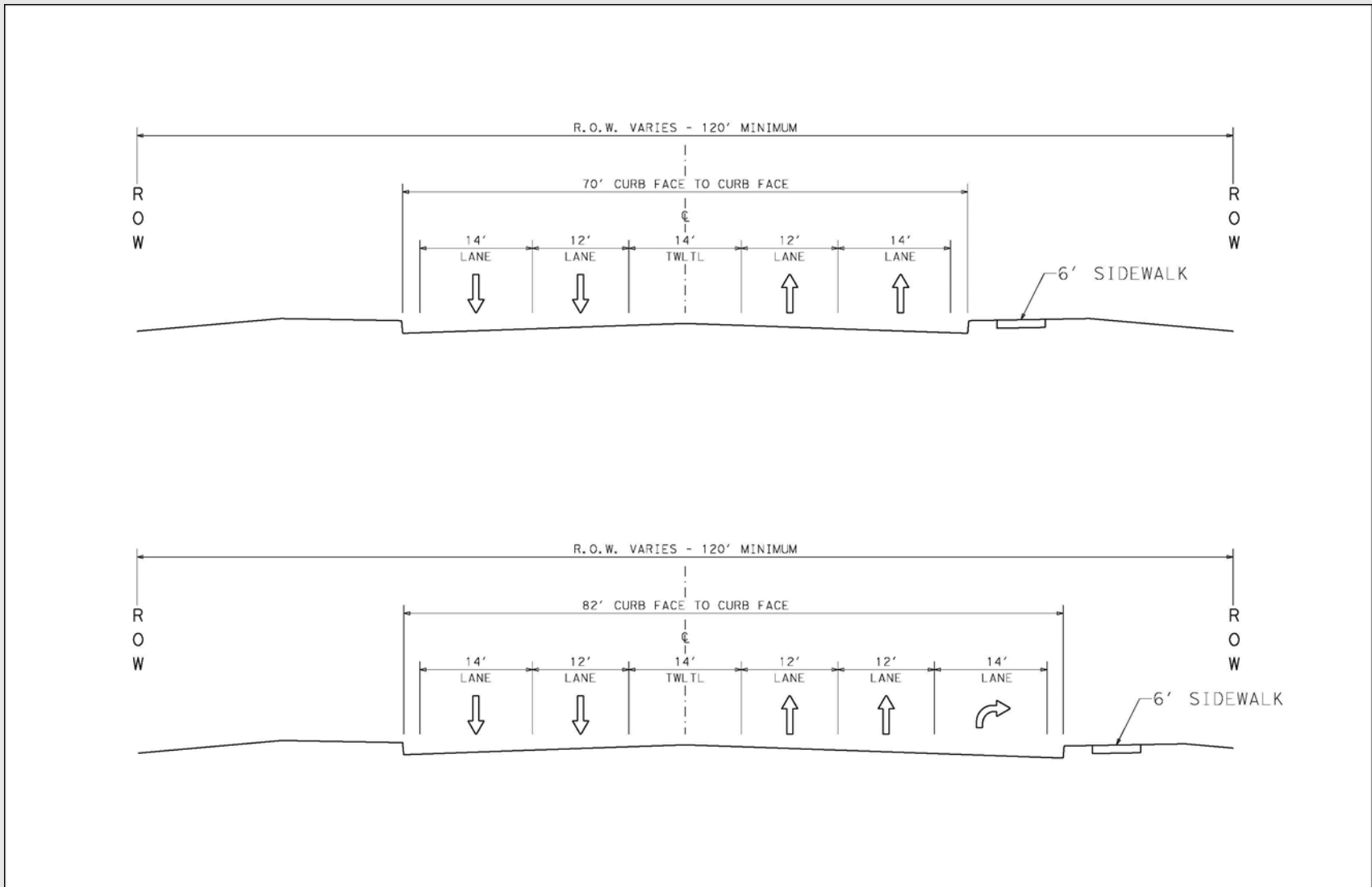

## - Estimated Quantities

- 12,500 CY of excavation
- 13,200 CY of embankment
- 70,000 tons of HMAC
- 7,000 LF of concrete sidewalk
- 10,000 LF of RCP storm drain
- HMAC level-up and planing to correct pavement cross-slopes

- June 2017 Letting
- Current Construction Estimate: \$6.5 million
- TxDOT to utilize CEI partnership for contract inspection



# Project Locations

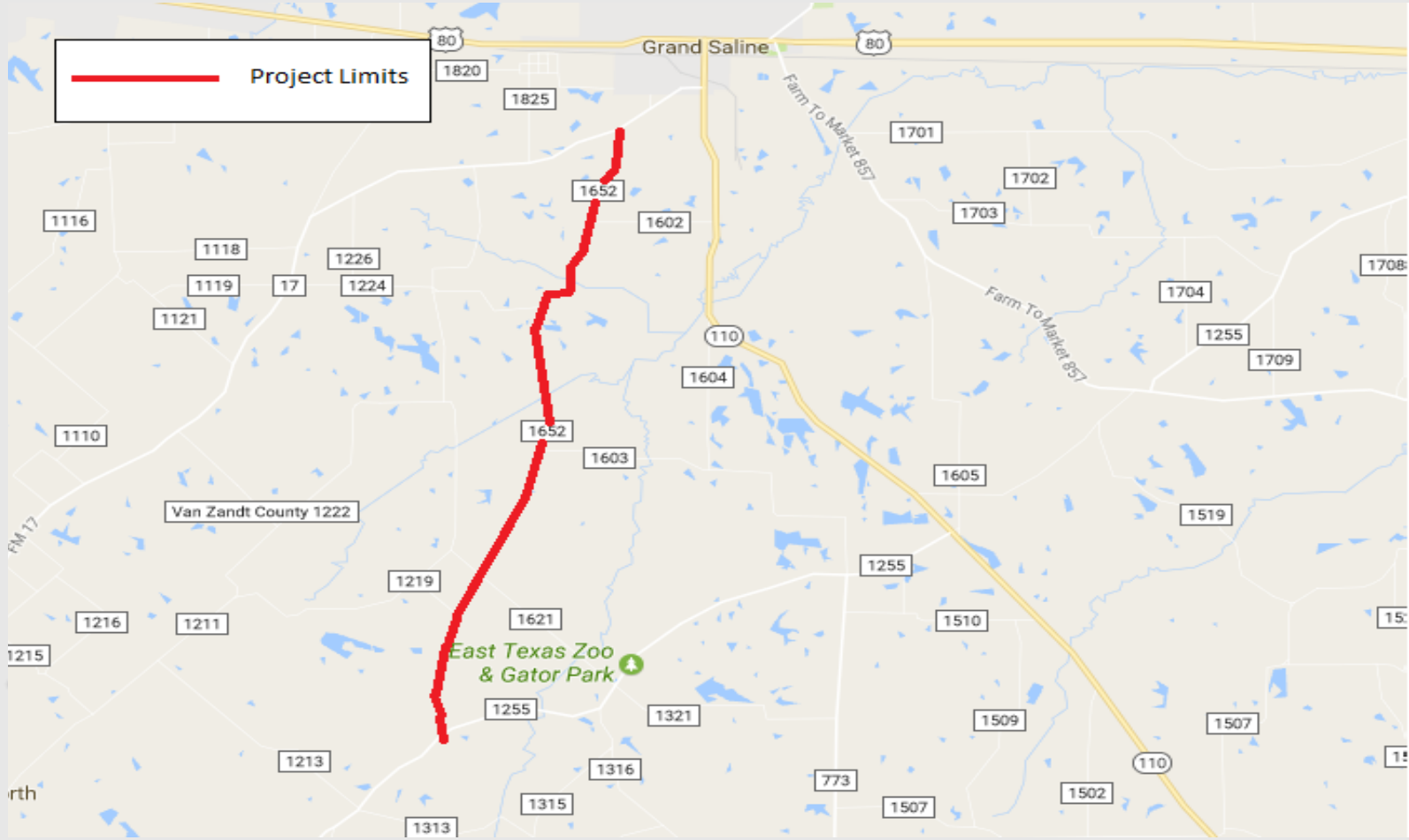

- **Widening FM 1652**
- **Project Limits: FM 17 to FM 1255**
- **Project Scope:**
  - Widen existing roadway from 20' to 24'
  - Safety treat fixed objects
  - Upgrade bridge and structure rail(s) to current design standards
  - Correct super-elevation(s) in various curves
- **Project Goals:**
  - Increase driver safety
  - Rehabilitation of roadway structure

## Existing Typical Sections

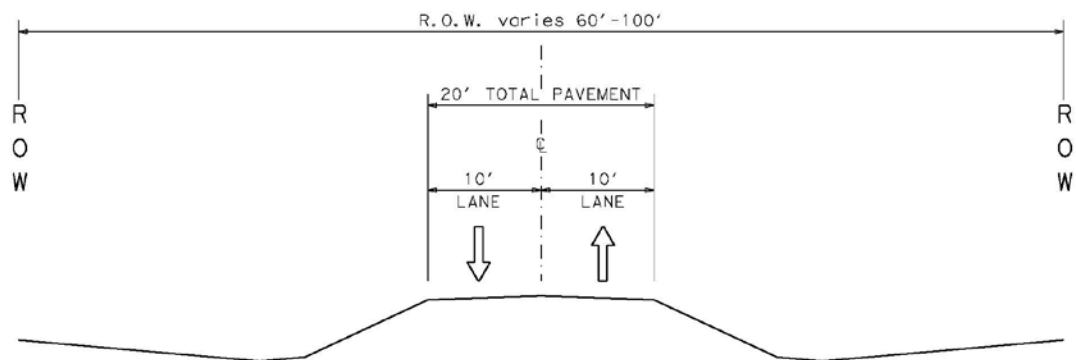

## Proposed Typical Sections

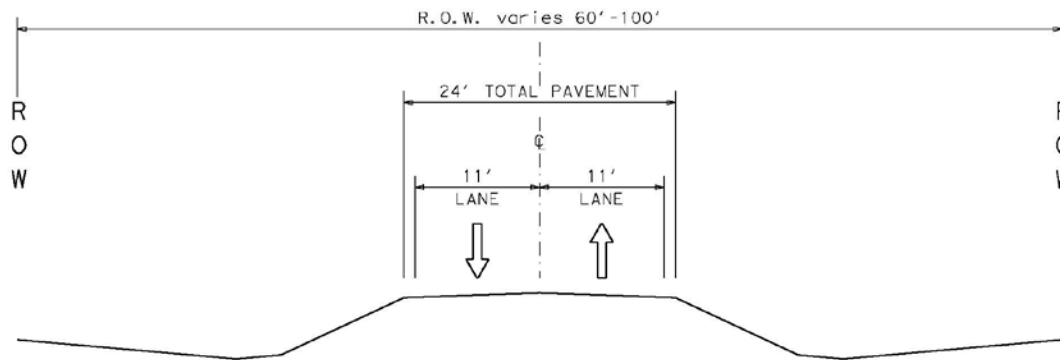

## - Estimated Quantities

- 81,000 GAL hot asphalt
- 2,500 CY aggregate
- 1350 TONS cement
- 84,000 SY 6" flex base
- 160 parallel structures replaced
- 19 cross structure extensions



- June 2017 Letting
- Current Construction Estimate = \$4.9 million

# QUESTIONS?