

Standard Highway Sign Designs for Texas



**Drawings may not be drawn to scale.
Do not photocopy for manufacturing.**

(This page left intentionally blank)

Guide Sign Design Guidelines

Design Guidelines

There are general guidelines to follow in the design of highway signs in order to conform to basic standards. Many of these guidelines are mentioned in various sections of the Texas Manual on Traffic Control Devices (TMUTCD), while others are derived from accepted practice in sign design and layout.

Standard Sign Guidelines

Highway signs with standardized designs conforming to the general guidelines (like most regulatory, warning, emergency management, school, railroad-highway grade crossing, and bicycle signs), are contained in this book and are shown with different standard sizes depending on the type of highway or facility where the sign is intended to be used.

Additional Guidelines for Standard Signs are:

- A. As a guide to choice of alphabets, tests have shown that, for any given legend, better legibility can be obtained by using a relatively wide spacing between letters than by using wider and taller letters with a cramped space.
- B. Use of Series B alphabet is for street names, parking signs, and other similar signs where limited breadth and stroke widths are required for design purposes.
- C. Lettering on street name signs should be at least 6 inches high (TMUTCD, Section 2D.43). Supplementary lettering to indicate type of street or section of city may be in smaller lettering but at least 3 inches high.
- D. An accepted "rule-of-thumb" to follow for legibility for signs other than Interstate is to have 1 inch of letter height for every 40 feet of desired legibility.

Guide Sign Dimensioning

Although some guide signs also have been standardized and are included in this book, most guide signs need to be designed separately because of the variability in message or legend. For most guide signs, there can be no rigid standardized sizes.

Message variability controls overall sign dimensions. Whenever practicable, the overall

dimensions of the sign plates should be in multiples of 6 inches.

The use of a smaller than "nominal" size for the various four types of roadway signs may sometimes be justified. For instance, a sign mounted over a particular roadway lane to which it applies may have to be limited in width to the lane width. In some cases, vertical clearances may limit the vertical dimension of the sign. On the other hand, a larger than "nominal" sign may be desirable where greater legibility or emphases is needed. When a variation in the "standard" size is necessary, a reduced or enlarged (as the case may be) letter height, interline, and edge spacing may be used but should be as nearly comparable to standards as possible.

Guide Sign Letter Style

Guide Sign lettering shall be "Clearview." Sign lettering is normally all caps except the destination names may be in upper and lowercase lettering.

Letter Sizes for Guide Signs

For guide signs on expressways and freeways, the prescribed numeral and letter sizes, according to interchange classification and component of sign legend, appear in Tables 2E-1T, 2E-4T and 2E-5 of the TMUTCD. The minimum sizes specified should be exceeded where conditions indicate a need for greater legibility.

For conventional roads in rural districts on major routes, the principal legend on guide signs shall be in letters 6 to 8 inches in height. On low-volume roads and on urban streets with speed of 25 mph, the principal legend shall be in letters at least 4 inches high.

Amount of Legend on Guide Signs

The TMUTCD states that regardless of letter size, the legend on a guide sign must be kept to a minimum to be instantly legible. For example, on expressways, the legend on a guide sign should only have two destinations and the directional copy. Directional copy, not exceeding three lines, may include symbols, route numbers, arrows, cardinal directions, interchange number(s), and other exit instructions. Conventional road guide signs should be limited to three lines of principal legend which includes only place names, route numbers, and street names.

Guide Sign Arrows

The "Type A", "Type B" and "Down" arrows are to be used for guide signs and recommended applications are stated in Sections 2D.8 and 2E.19 of the TMUTCD.

Guide Sign Borders

Border widths should not exceed the stroke width of the major lettering of the sign. For guide signs, smaller than 60 square feet, a width of 1 to 1¼ inch may be used; for those exceeding 60 square feet the border should be 2 inches wide; and for unusually large signs, a border of 3 inches wide is appropriate.

The corner radii of guide sign borders should be approximately one-eighth of the lesser side dimension except the radii should not exceed 12 inches on any sign. The area outside the corner radius on large signs may need to be trimmed, except for signs made from extruded aluminum panels.

Spacing on Guide Signs

Interline spacing should be approximately three-fourths the average of the capital and/or uppercase letter heights in adjacent lines. Interline spacing shall not be reduced to less than ½ the average height. Spacing between a route marker and the line of text below should be equal to three-fourths the average height of the numeral in the route marker and the tallest letter in that adjacent line. Measurement shall be from the lowest point of the route marker and the top of the tallest letter in the line of text. Interline spacing between an upward sloping arrow and a line of text and/or a route marker should be approximately three-fourths the letter height of the line of text or the numeral inside the marker.

Lateral spacing to the inside edge of the vertical borders shall be the same as the height of the largest letter on the sign. Each line of copy should be centered within the sign borders. Spacing to the inside edge of the top and bottom borders should be approximately equal to the average of the letter and/or numeral height of the adjacent line of text. When a downward pointing arrow is part of the last line of text, spacing should be equal to the average of the arrow and letter height. If an arrow is the only item in the last line, spacing shall be measured from the lowest point of the arrow and be the same as the spacing at the top of the sign. Lateral spacing between each item (words, route markers, numbers and/or arrows) in any given line of text should be approximately 1 to 1½ times the capital

and/or uppercase letter height used in that line. If 2 or more route markers are in the same line of text they shall be optically centered on the sign with spacing between the markers at not less than the height of the numeral within the route markers.

Examples of the design of guide signs using the above guidelines are shown on the following pages.

Diagrammatic Guide Signs

Design of diagrammatic signs follow the same principles and guidelines previously covered plus additional guidelines necessary for the details related to graphic components. Diagrammatic signs shall be designed in accordance with the following criteria:

1. The graphic legend shall be a plan view showing a simplified off-ramp arrangement.
2. Only one destination may be shown for each arrowhead, with a maximum of two destinations per sign.
3. The graphic should not depict deceleration lanes. A black on yellow "EXIT ONLY" panel should be used to supplement a lane drop graphic.
4. The shaft for the exit ramp movement should be shorter than, but not separated from, the through movement graphic.
5. Arrow shafts should contain lane lines where appropriate and route shields shall not be used as a substitute for arrowheads.
6. Route shields, cardinal directions, and destinations should be clearly related to the arrowhead, and the arrowhead should point toward the route shield for the off movement.
7. The cardinal direction should generally be placed adjacent to the route shield and the destination should be placed below and justified with the route shield.
8. Exit number panels should be located toward the top left edge of the sign for a left exit and toward the top right edge for right exits.

The above guidelines were based upon the results of a research project conducted by the Federal Highway Administration. This research generated ideals for various diagrammatic design features.

These ideal features have been modified so more economical designs could be obtained.

Specific design standards for graphic components are presented in the table below and other recommended features are shown in the design illustrations in the following pages. The illustrations

shown were designed through a trial and error procedure and will provide the designer with the guides and elements needed to design an economical diagrammatic sign while maintaining a clear and simple message.

GRAPHIC COMPONENT	SIZE
Lane Width	5" *
Lane Lines	1" x 6"
Space between Lane Lines	6"
Arrowheads	Stand "Up" Arrow
Stem Height (to upper point of departure-minimum)	30"
Space between arrowhead and route shield	12"
Space between route shield and cardinal direction, should be equal to the largest letter/number height in that line.	
*Wider lane widths appear to better meet the needs of older drivers.	

Minimum Letter and Numeral Sizes for Advance Guide and Exit Direction Signs

Type of Sign and Sign Elements	Minimum Size in inches
Exit Panel	
Word	10 CV 4W
Numeral and Letter	15 CV 4W
Interstate Route Sign	
Numeral (see note 1 below)	18 D Series
Shield (1-2 Digit)	36 x 36
Shield (3 Digit)	45 x 36
U.S. or State Route Sign, Business, Loop or Spur Interstate Route Sign	
Numeral (see note 1 below)	18 D Series
Shield (1-2 Digit)	36 x 36
Shield (3 Digit)	45 x 36
U.S. or State Route Text Identification (Example: US 56)	
Numerals & Letters	15 CV 5WR (18 CV 5WR *)
Cardinal Direction	
First Letter	15 CV 5WR (18 CV 5WR*)
Rest of Word	12 CV 5WR (15 CV 5WR*)
Auxiliary and Alternative Route Legends (Examples: JCT, TO, ALT, BUSINESS)	
Word	12 CV 5WR (15 CV 5WR*)
Name of Place, Street or Highway	
Word	16 CV 5WR (20 CV 5WR*)
Distance Message	
Numeral	15 CV 5WR (18 CV 5WR*)
Fraction	10 CV 5 WR (12 CV 5WR*)
Word	10 CV 5WR (12 CV 5WR*)
Exit Gore	
Word	12 CV 6W
Numerals & Letters	18 CV 4W

See following pages
for detail dimensions.



SAMPLE SIGN

TEXAS

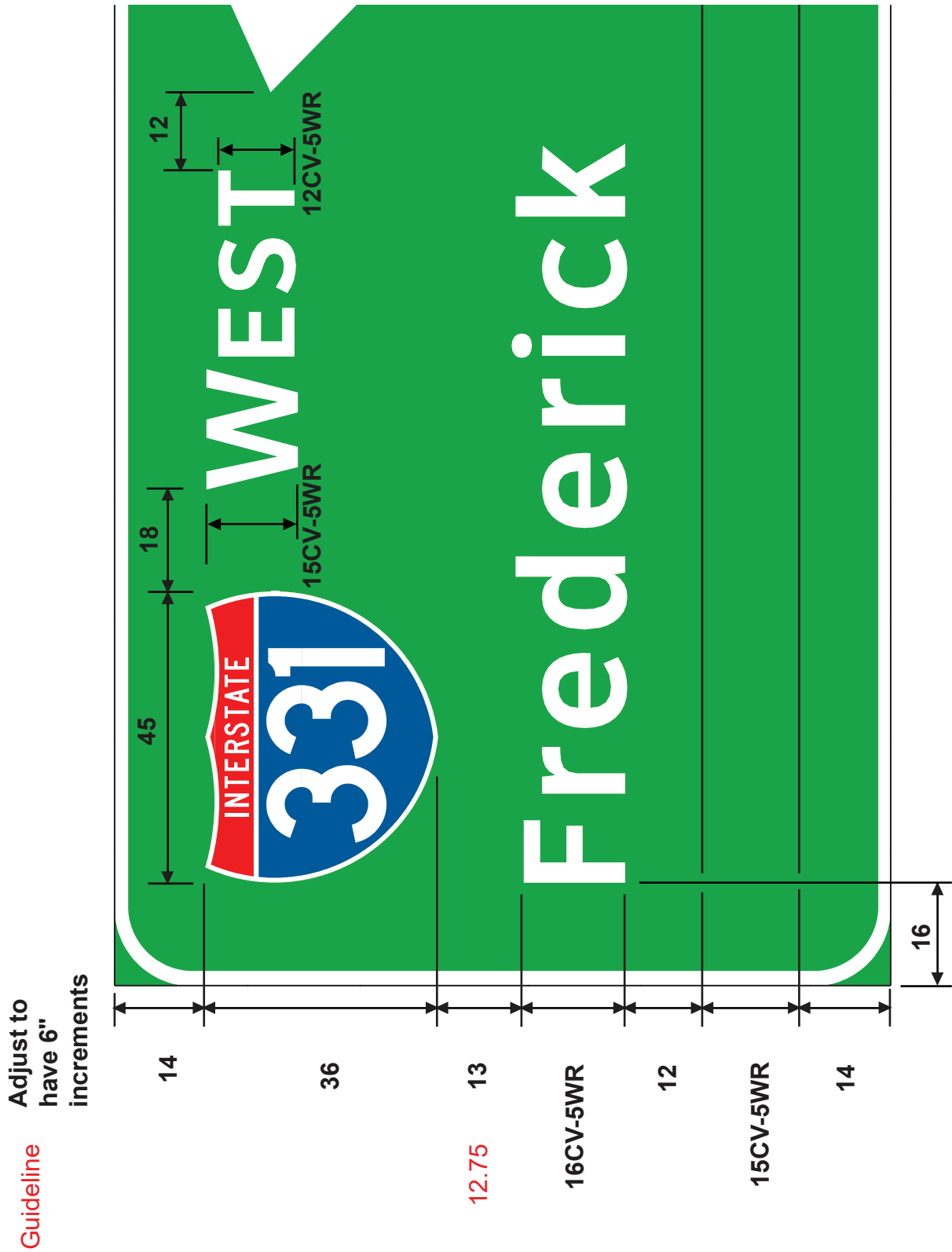

TEXAS

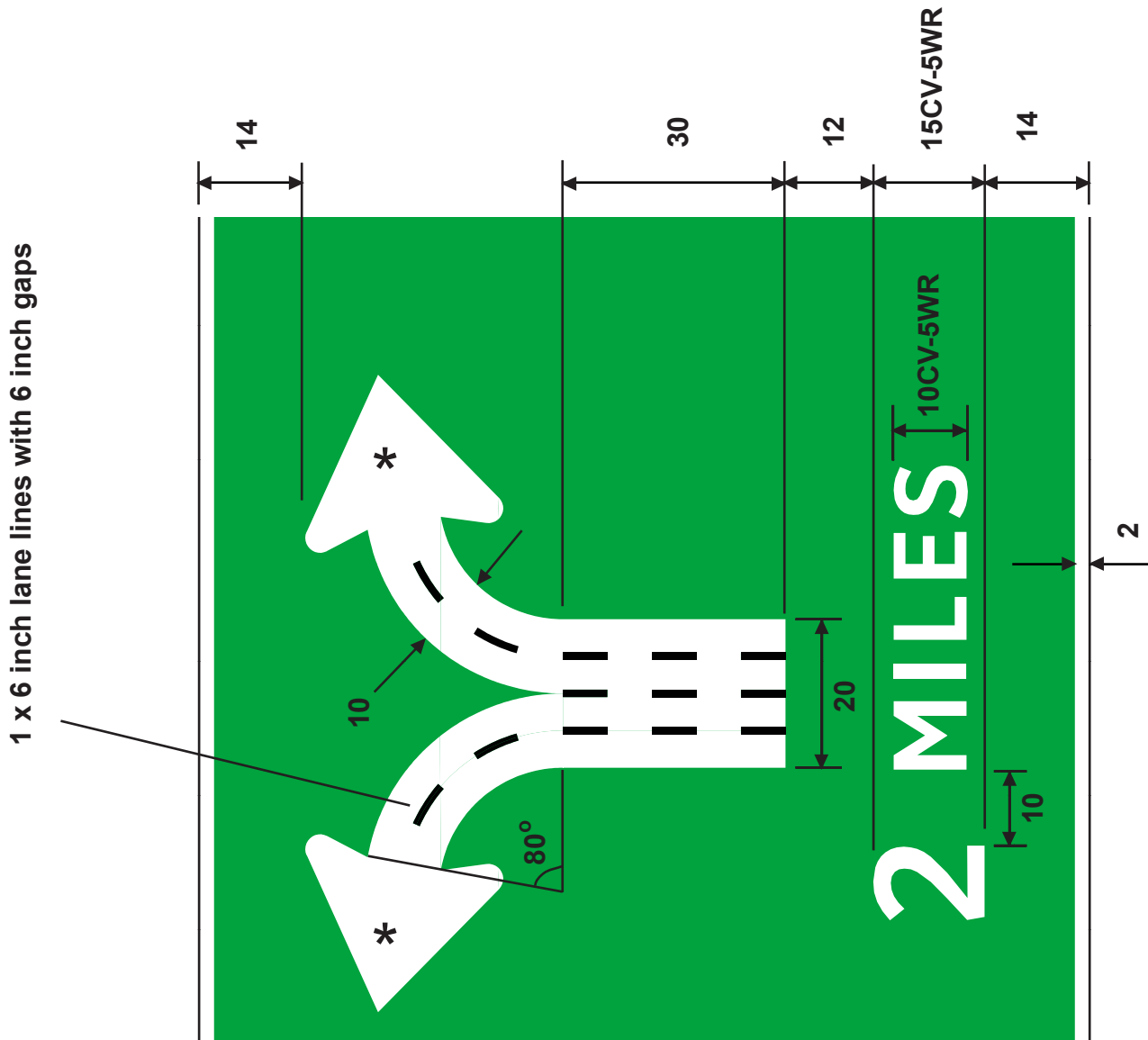

* See Symbol section for arrow design

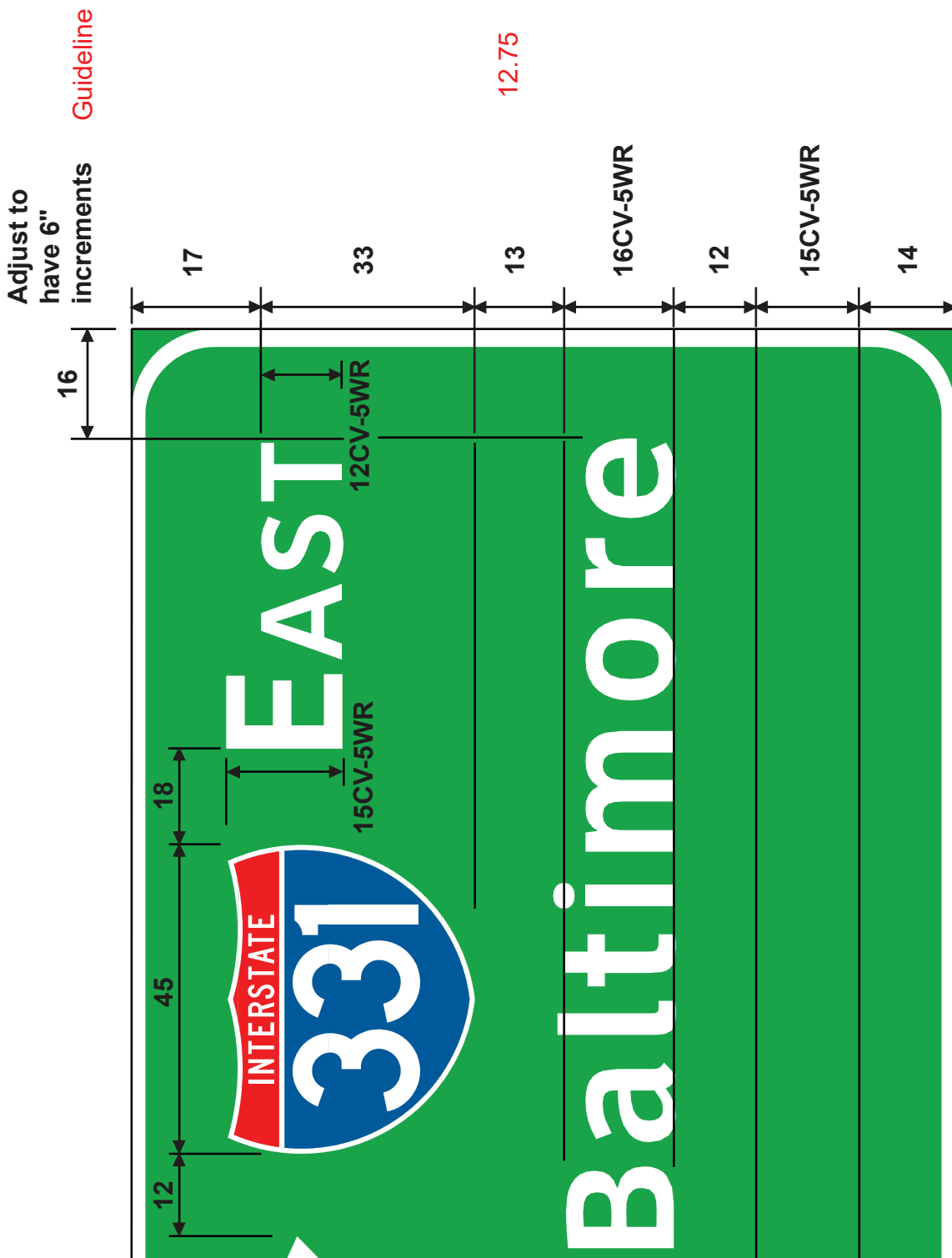

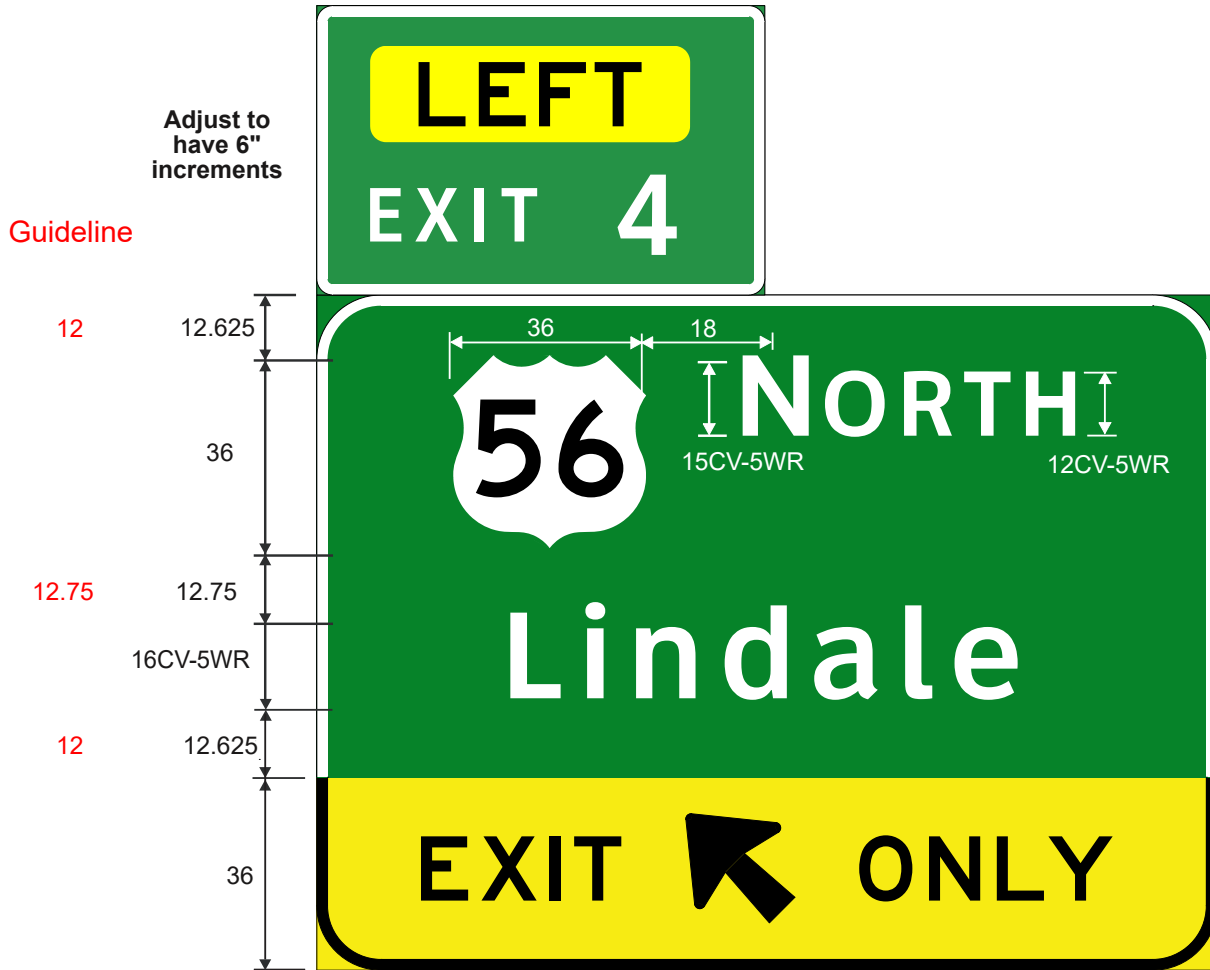

SAMPLE SIGN

Exit only sign with left exit plaque (Sample)

TEXAS

Adjust to have 6" increments **Guideline**

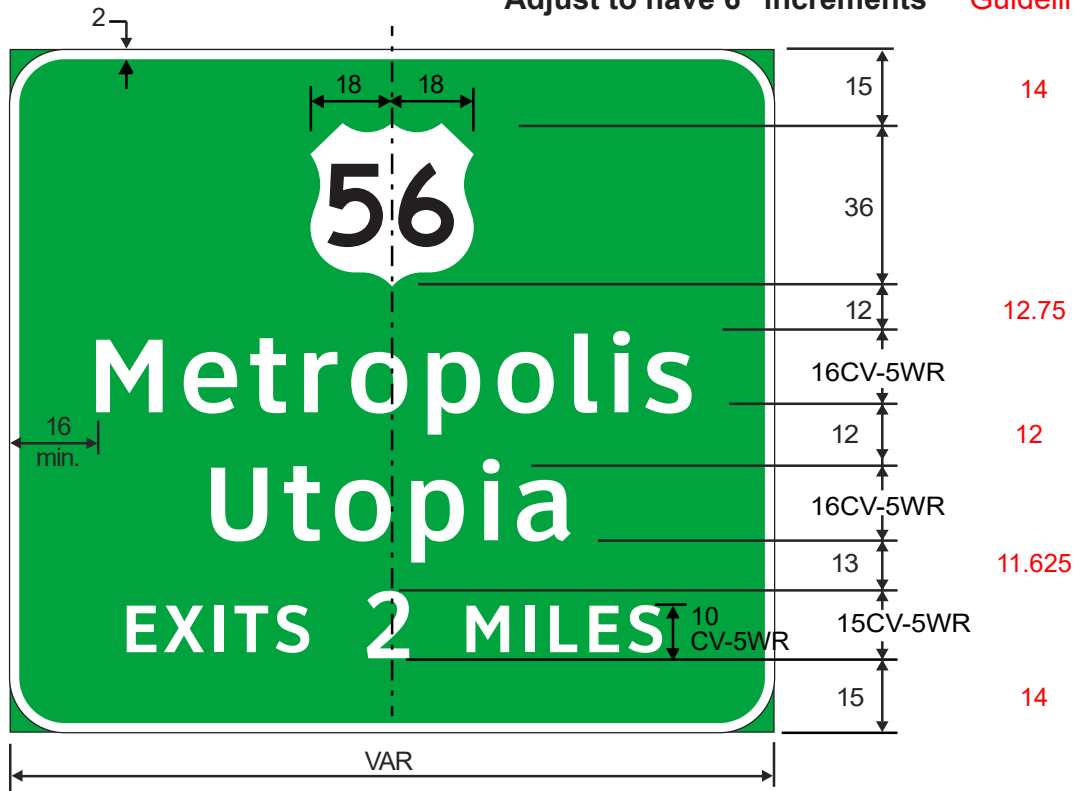

E1-1a

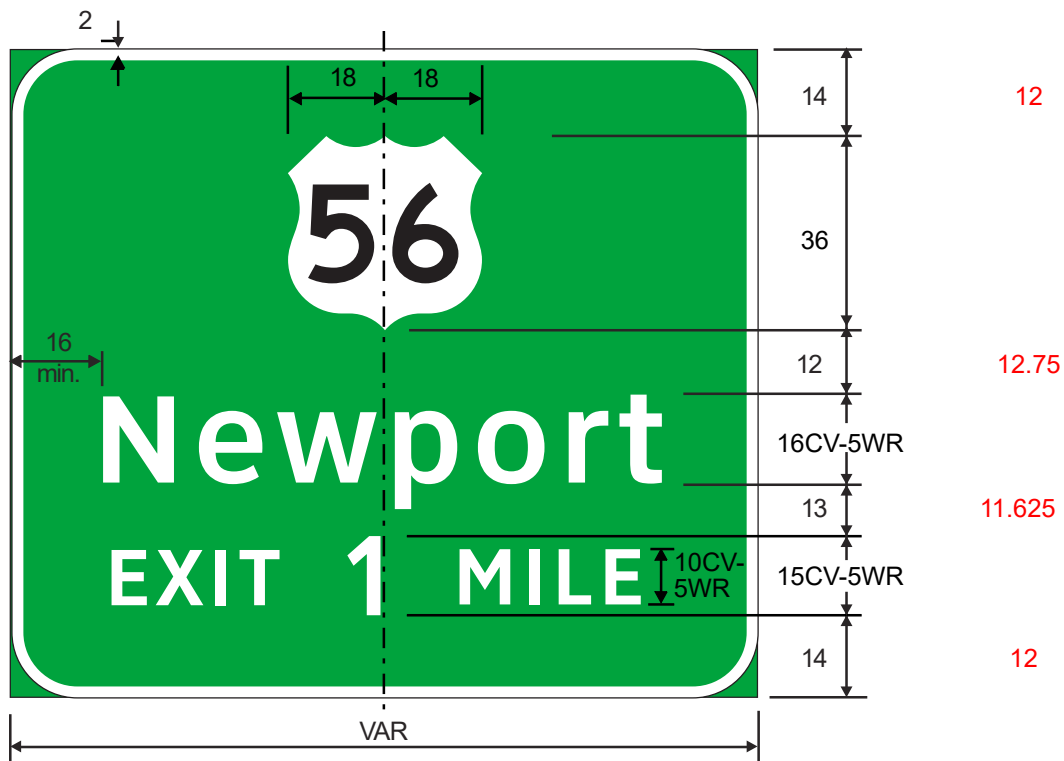

E1-2

EXIT X MILES

COLORS: LEGEND - WHITE
BACKGROUND - GREEN

TEXAS

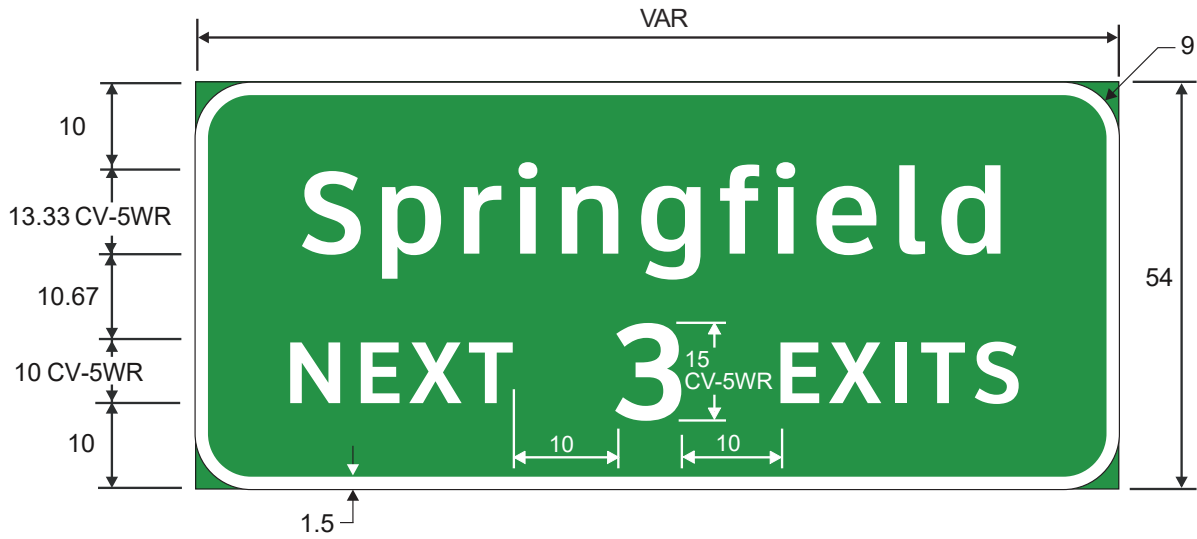

E1-2aT
NEXT X EXITS

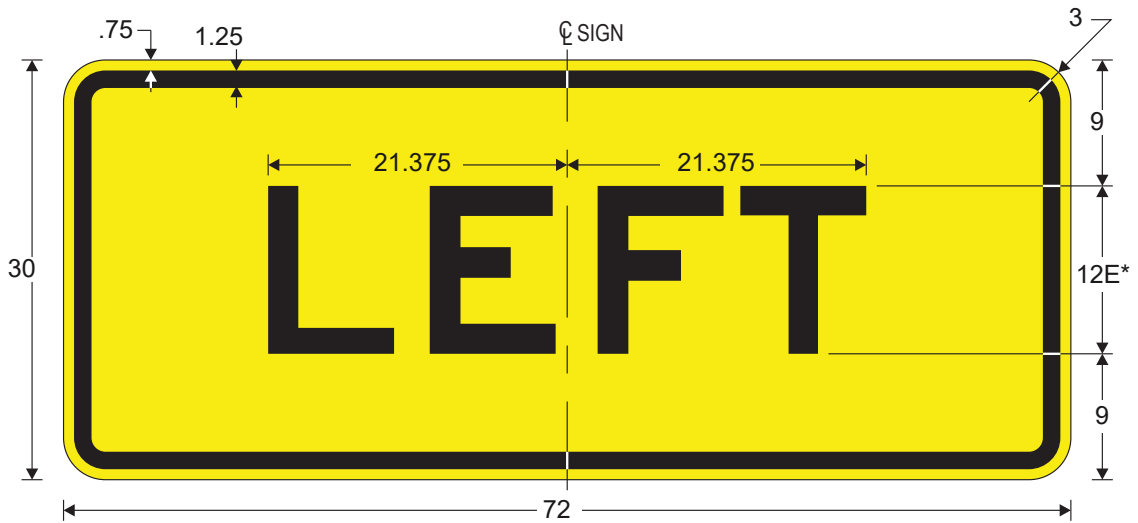

E1-5aP
LEFT (Plaque) * Increase character spacing 25%

COLORS: LEGEND - BLACK
BACKGROUND - YELLOW

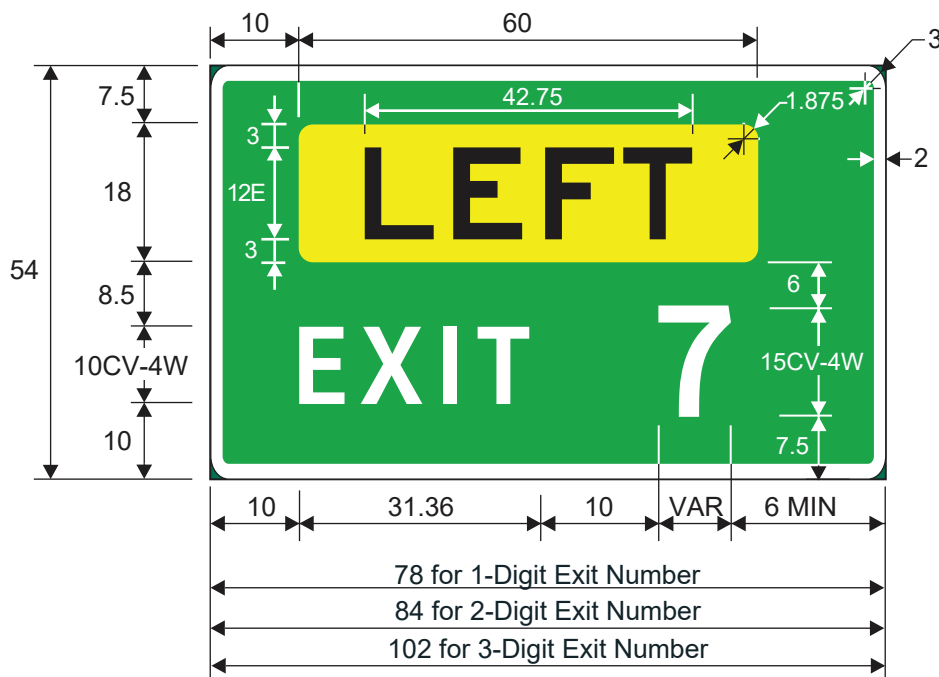

LEFT EXIT NUMBER (Plaque)

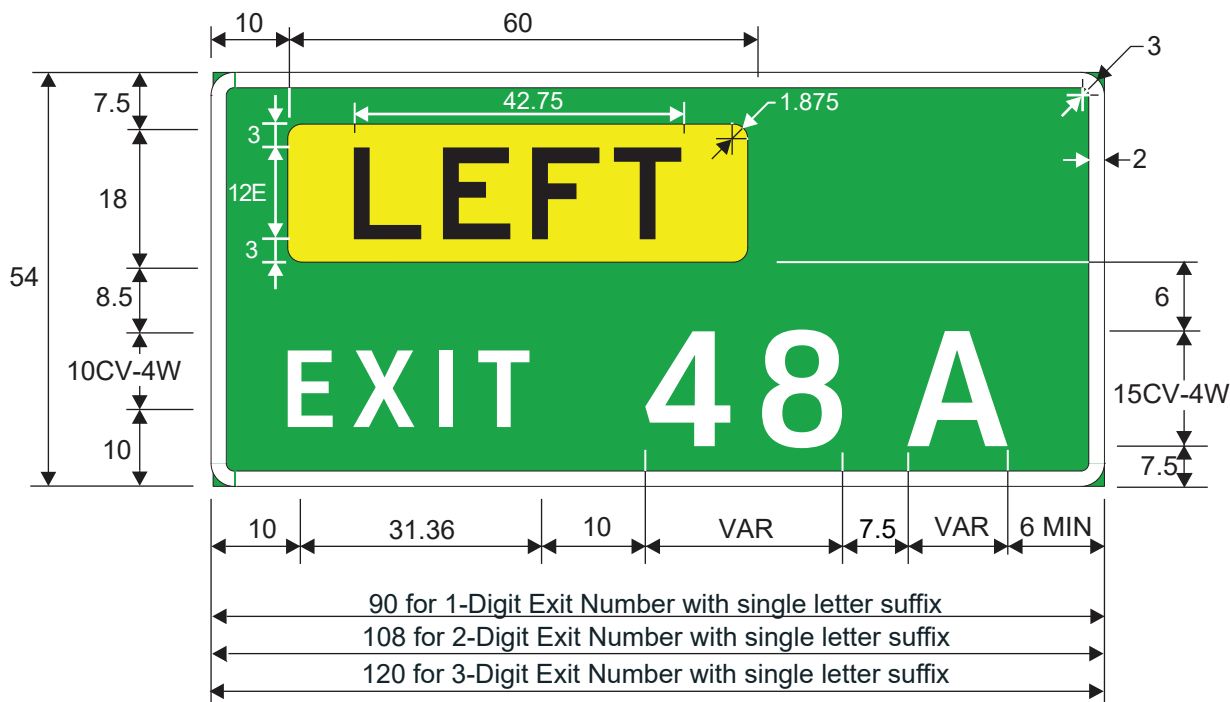

E1-5bP
EXIT NUMBER (Plaque)

COLORS: LEGEND, BORDER - WHITE
BACKGROUND - GREEN

TEXAS

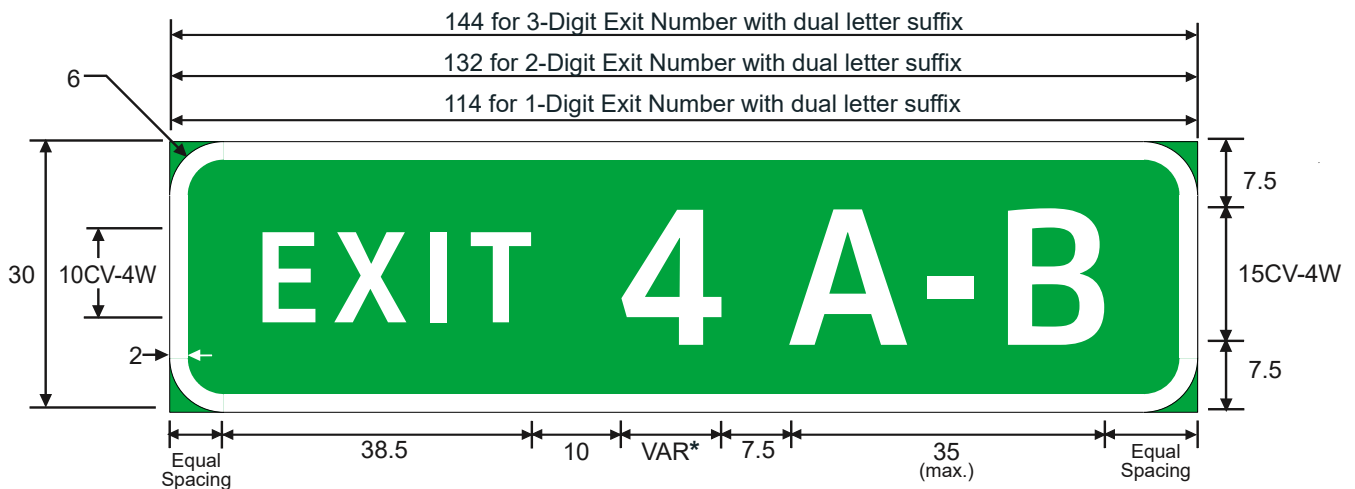
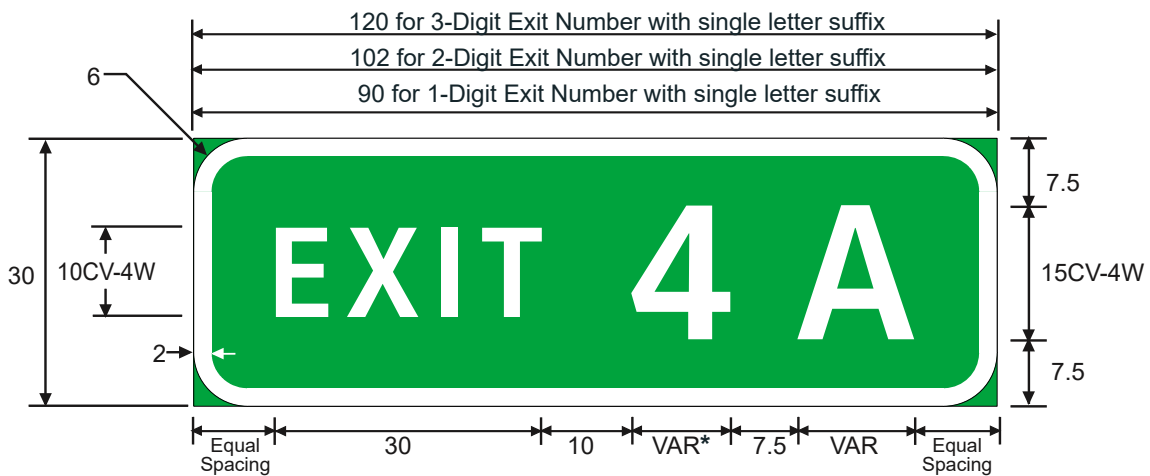
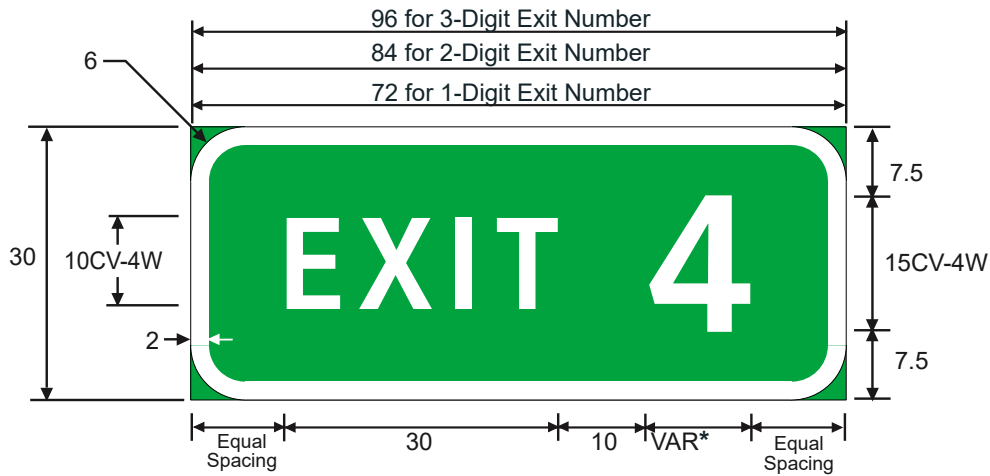

E1-5P
EXIT NUMBER (Plaque) (1 line)

(*) Max number length for 3-Digit Number is 41"

COLORS: LEGEND - WHITE
BACKGROUND - GREEN

TEXAS

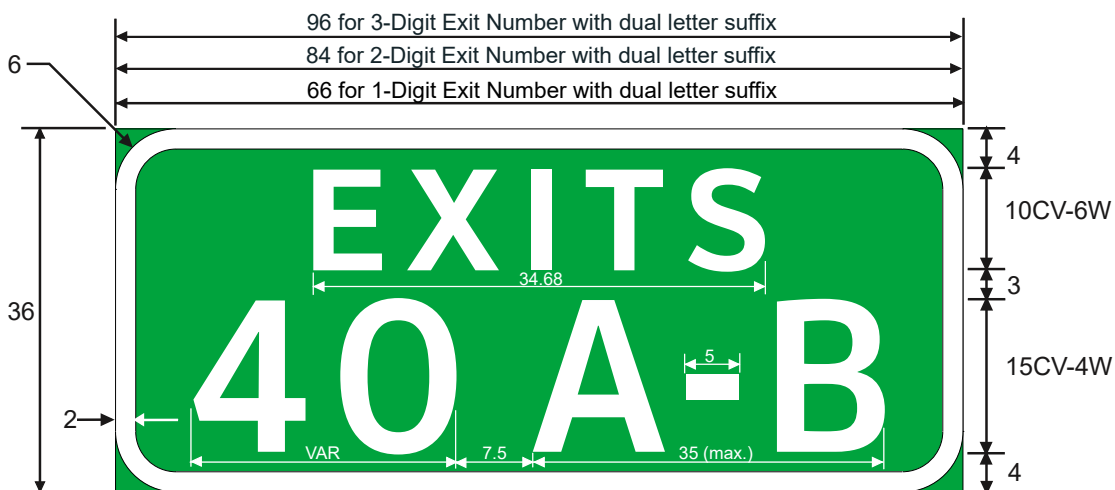
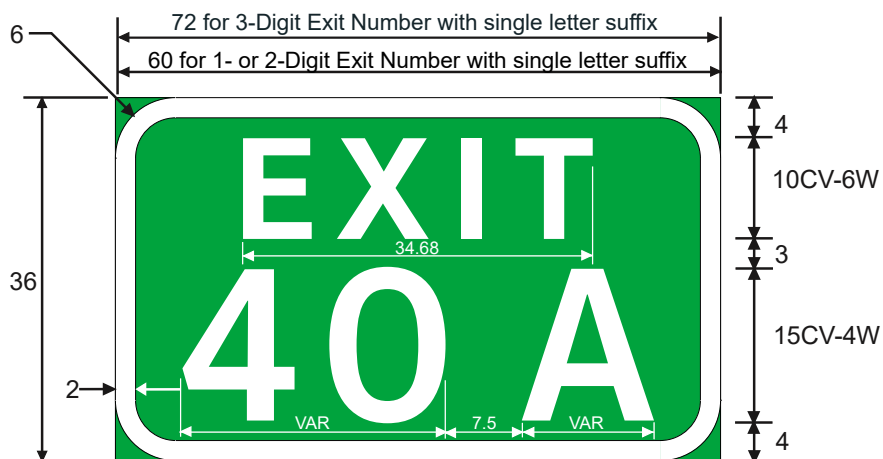
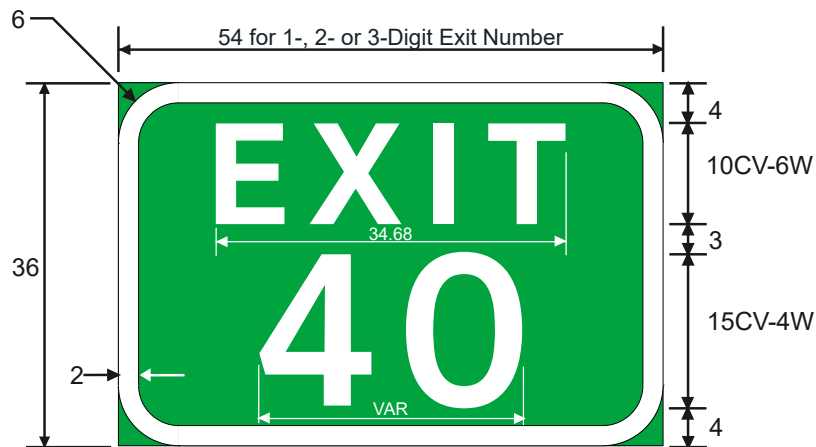

E1-5TP
EXIT NUMBER (Plaque) (2 line)

COLORS: LEGEND - WHITE
BACKGROUND - GREEN

TEXAS



E2-1

NEXT EXIT X MILES (1 line)



E2-1a

NEXT EXIT X MILES (2 line)



E2-2

SECOND RIGHT



E2-3

Typical dimensions as per E2-2

X MILE



E2-4

Typical dimensions as per E2-2

NEXT RIGHT

COLORS: LEGEND - WHITE
BACKGROUND - GREEN OR BLUE

TEXAS

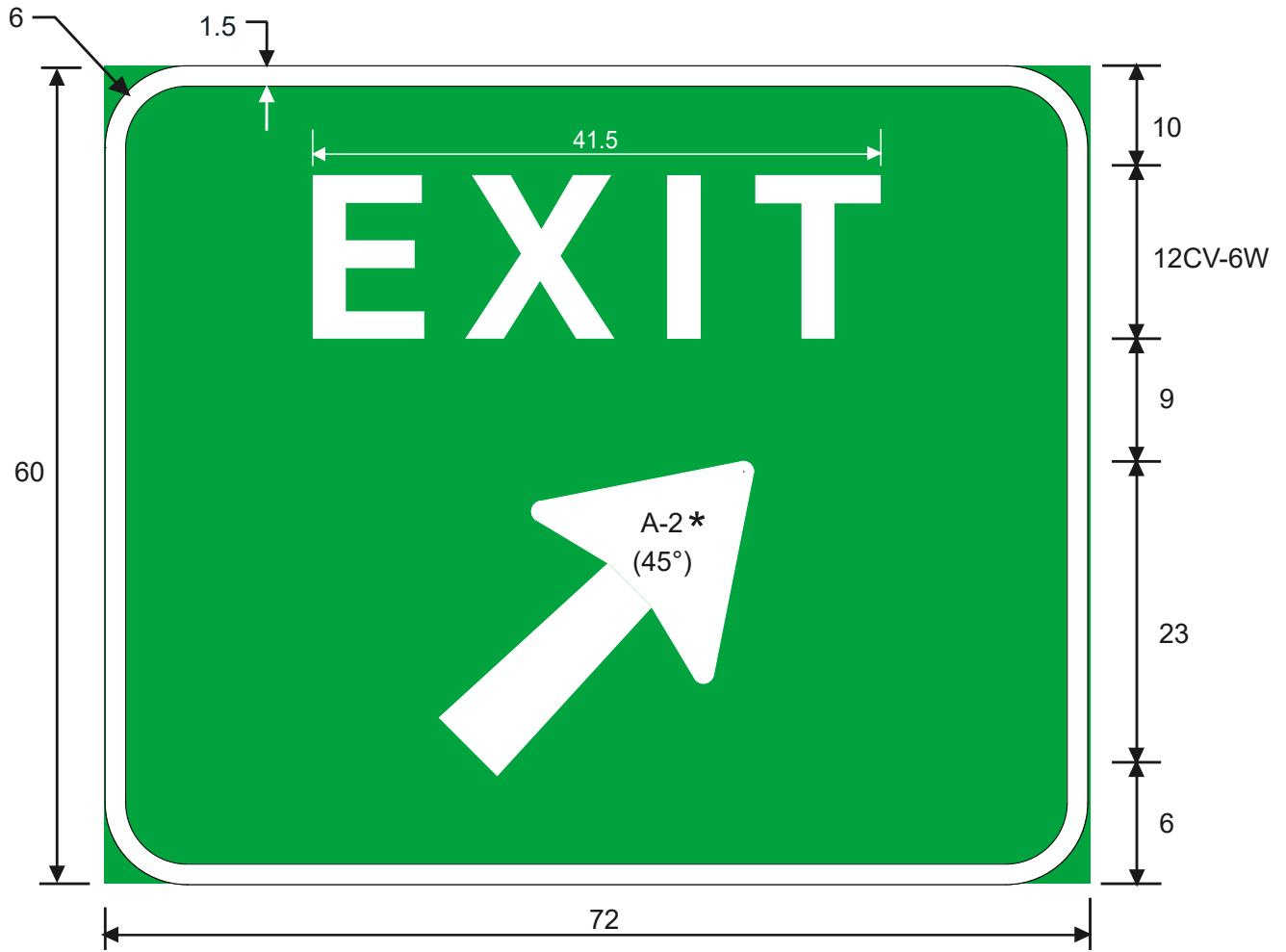

E5-1
EXIT GORE (with 45 Degree arrow)

* See Symbol section for arrow design

COLORS: LEGEND - WHITE
BACKGROUND - GREEN

TEXAS

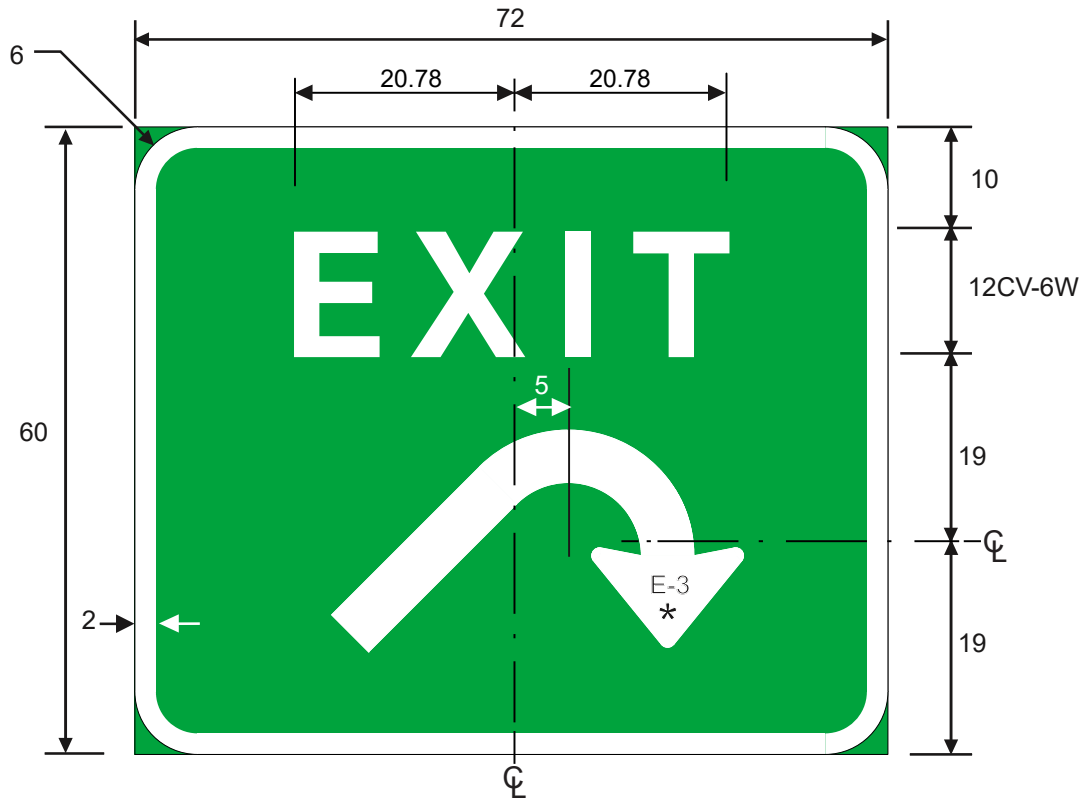

E5-1aT

EXIT GORE (with Turnaround arrow)

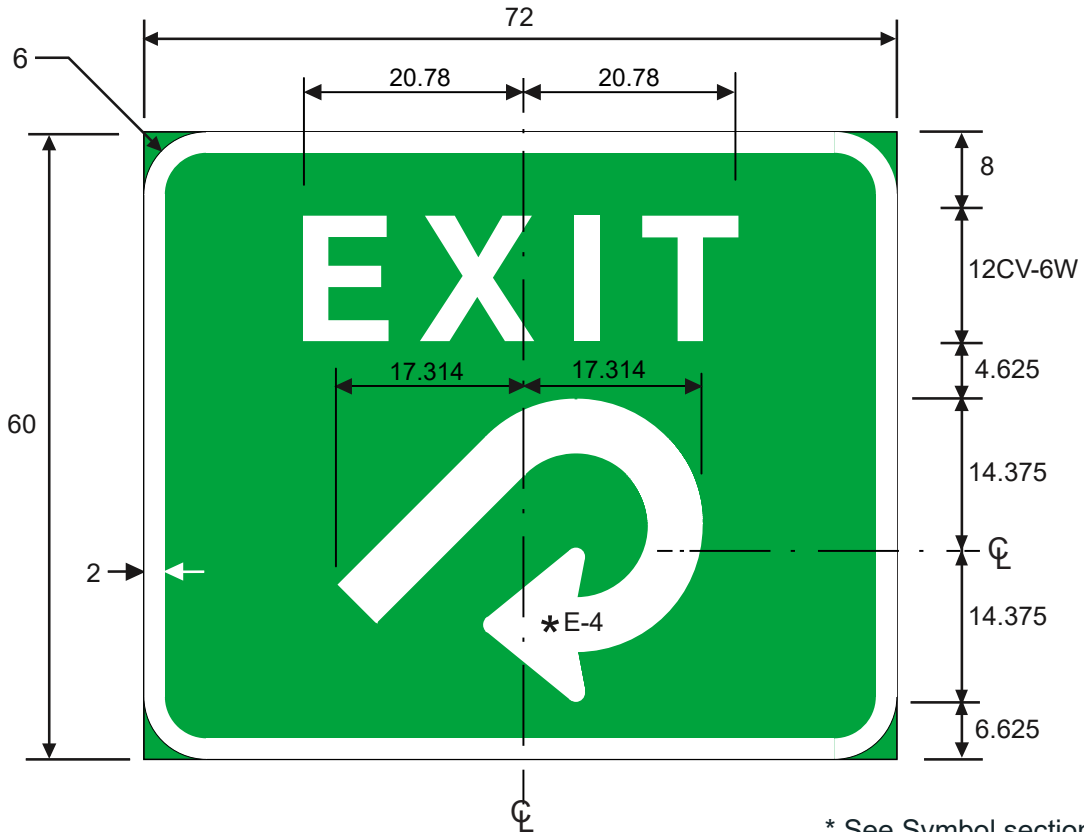

E5-1bT

EXIT GORE (with Cloverleaf arrow)

COLORS: LEGEND - WHITE
BACKGROUND - GREEN

* See Symbol section for arrow design

TEXAS

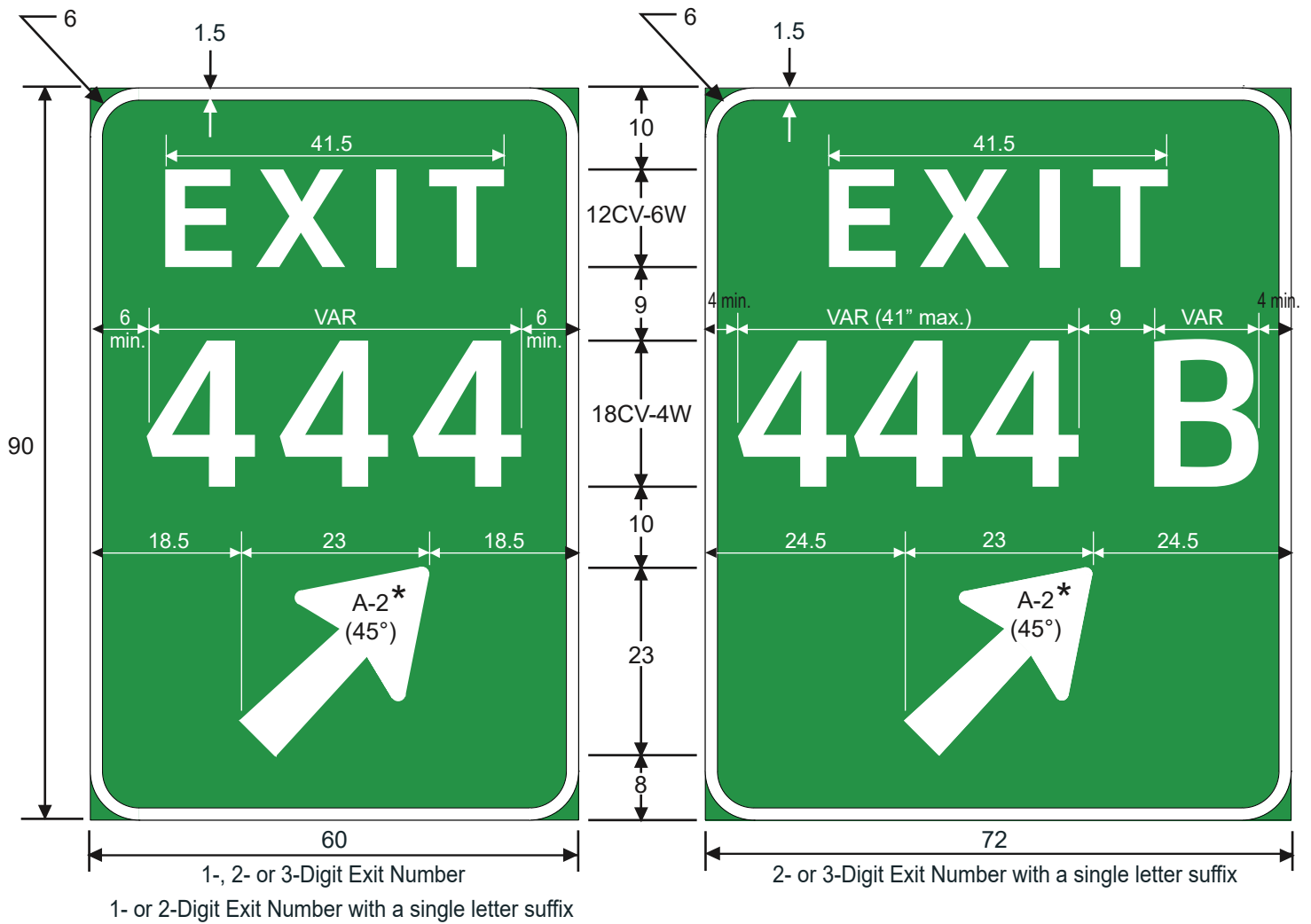

E5-1c

Narrow EXIT GORE (with 45 Degree angle)

* See Symbol section for arrow design

COLORS: LEGEND - WHITE
BACKGROUND - GREEN

TEXAS

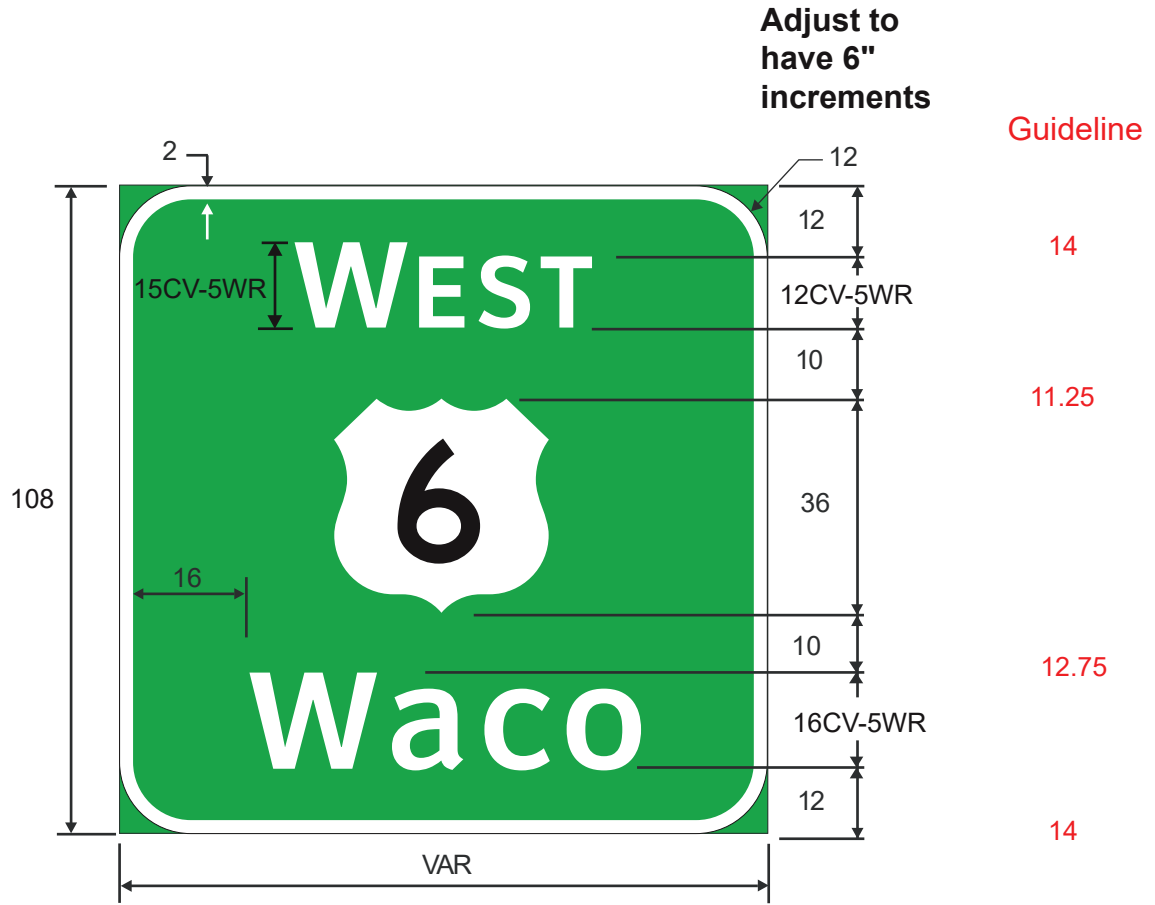

PULL THROUGH SIGNS

COLORS: LEGEND - WHITE
BACKGROUND - GREEN

TEXAS

Adjust to have 6" increments **Guideline**



E7-2T (2 line)

Post-Interchange Distance Sign

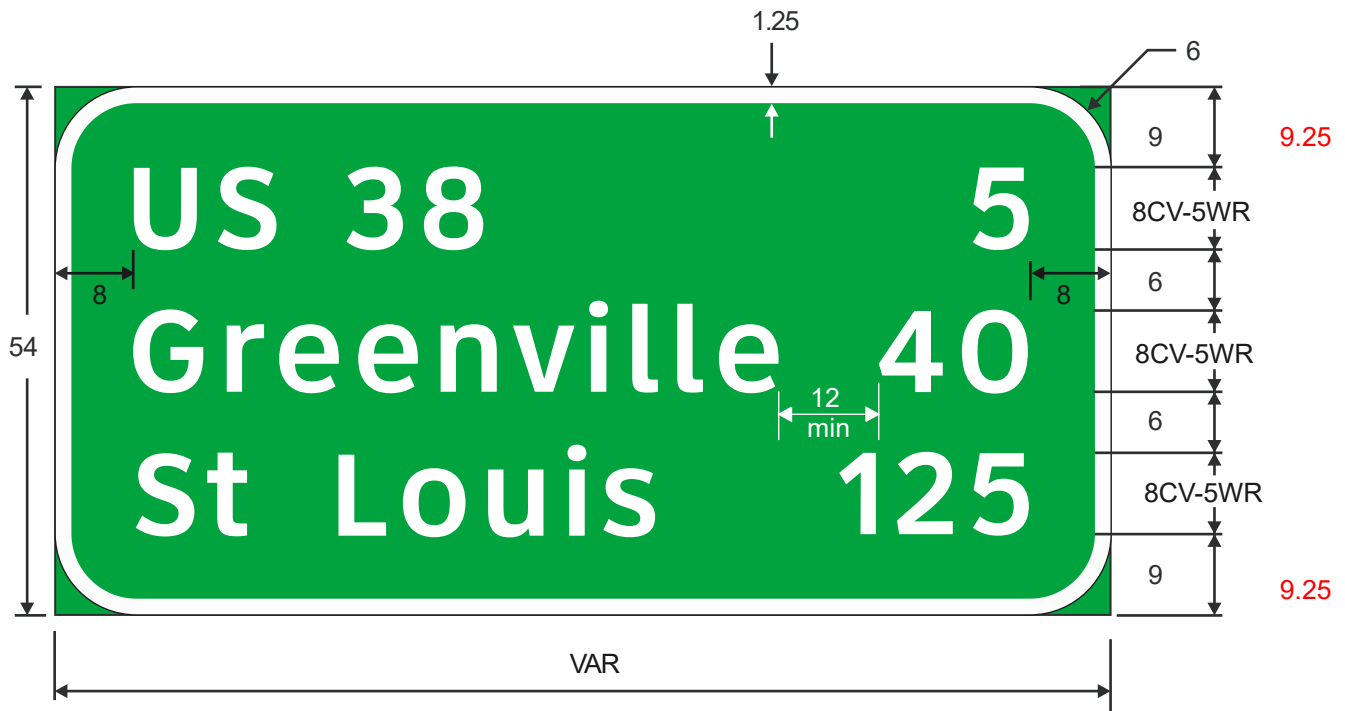

E7-3T (3 line)

One line expressway destination sign shall use a 24 inch sign blank.

Post-Interchange Distance Sign

COLORS: LEGEND - WHITE
BACKGROUND - GREEN

TEXAS

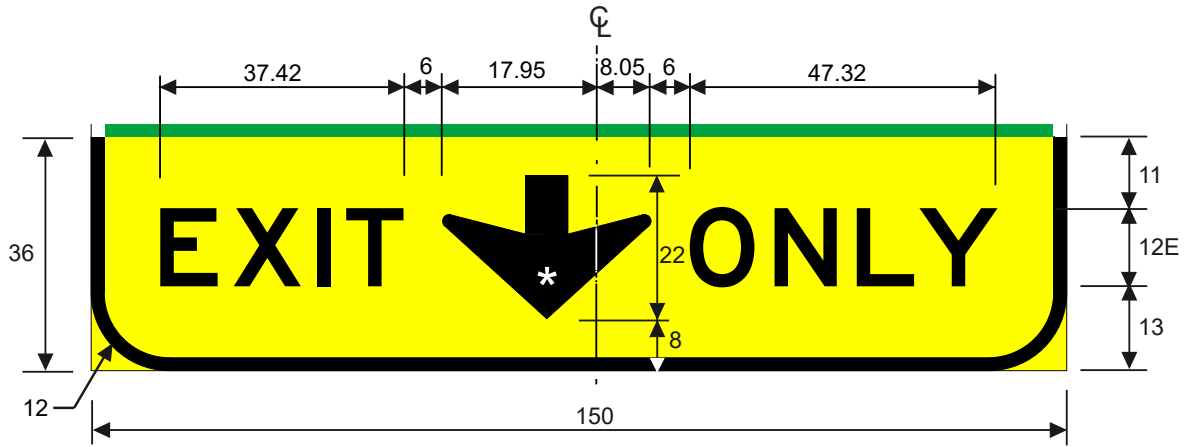

E11-1T (Down Arrow)

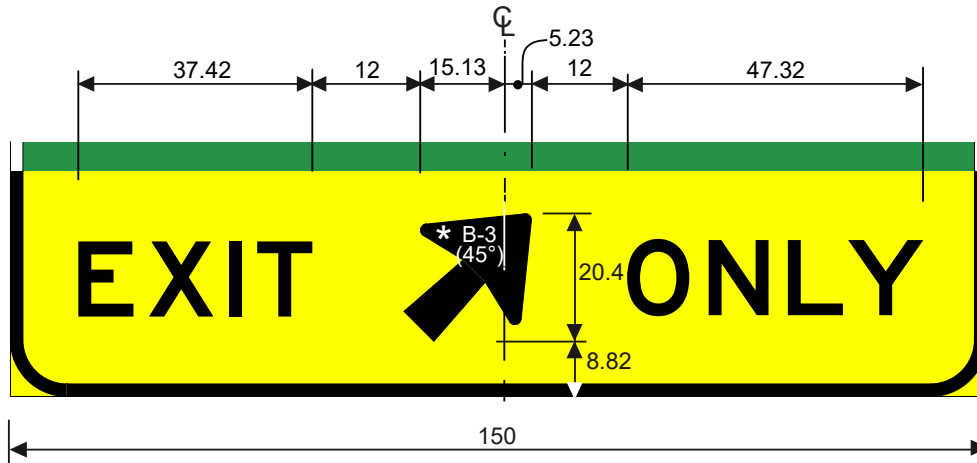

E11-1T (R)
(with 45 Degree arrow)

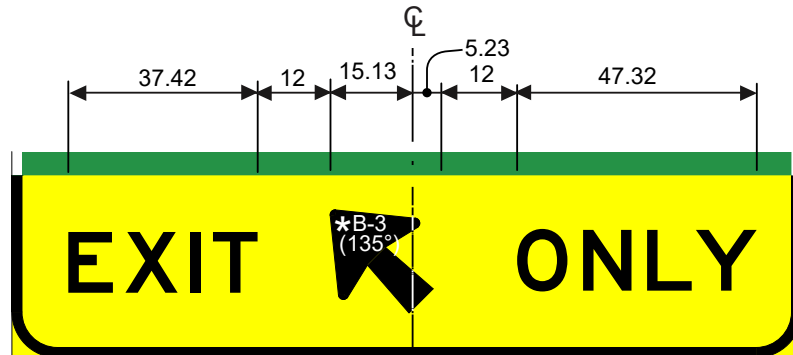

E11-1T (L)

EXIT ONLY - 45 Degree Arrow * See symbol section
arrow design

COLORS: LEGEND - BLACK
BACKGROUND - YELLOW

TEXAS

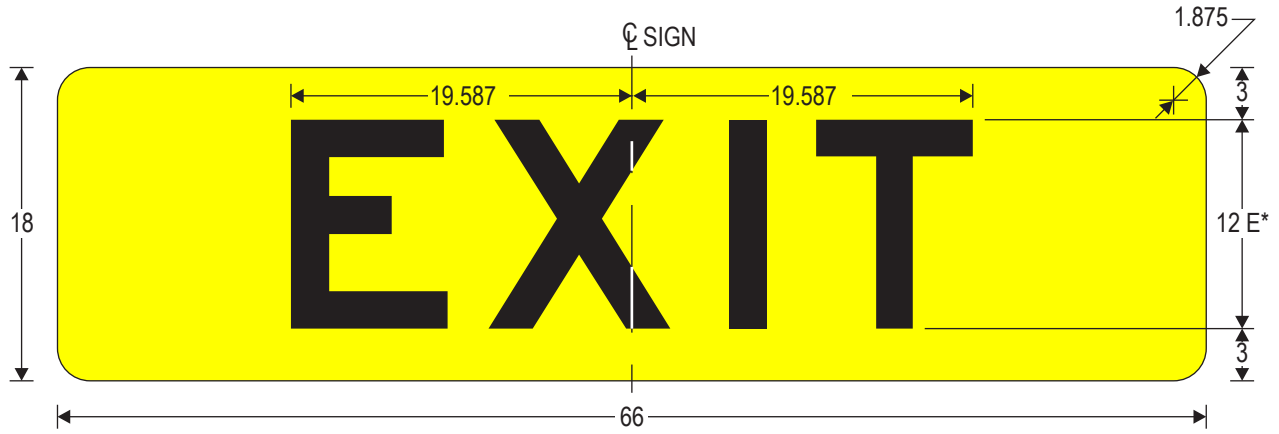

E11-1a
EXIT

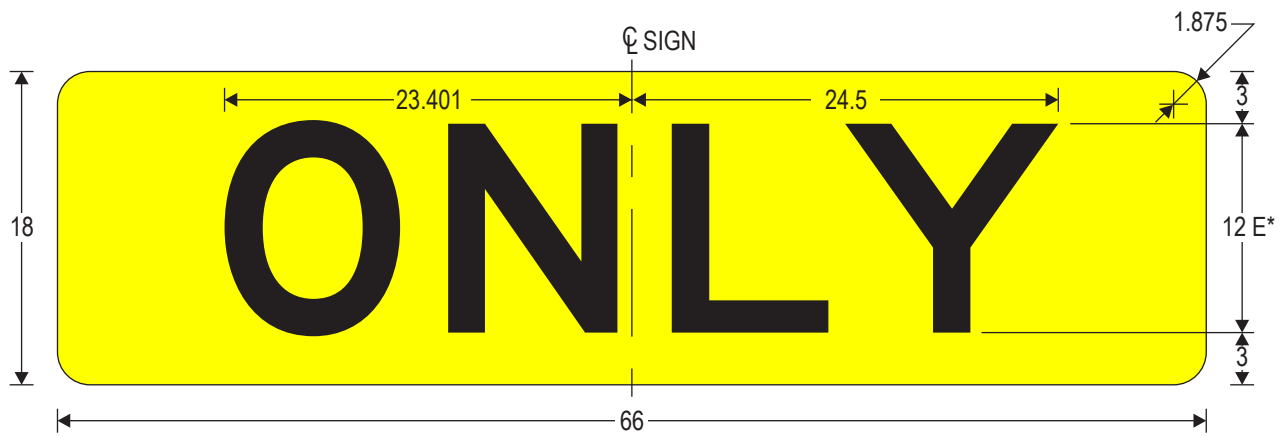

E11-1b
ONLY

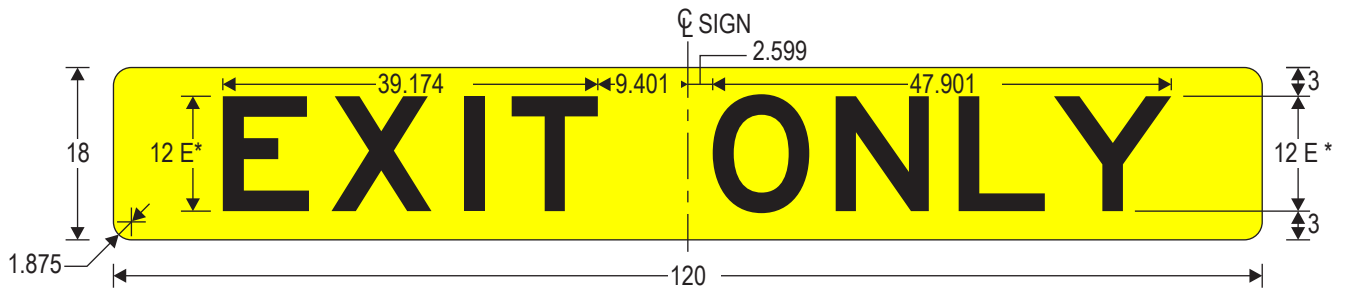

E11-1c
EXIT ONLY

* Increase character spacing 40%.

COLORS: LEGEND - BLACK
BACKGROUND - YELLOW
NO BORDER

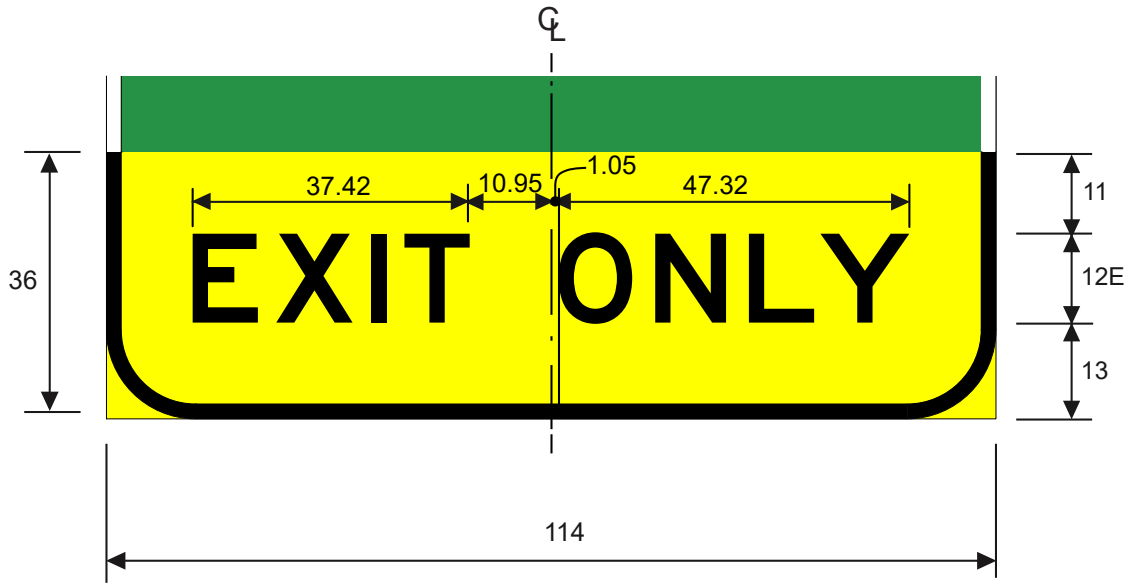

E11-1aT
EXIT ONLY

COLORS: LEGEND - BLACK
BACKGROUND - YELLOW

TEXAS

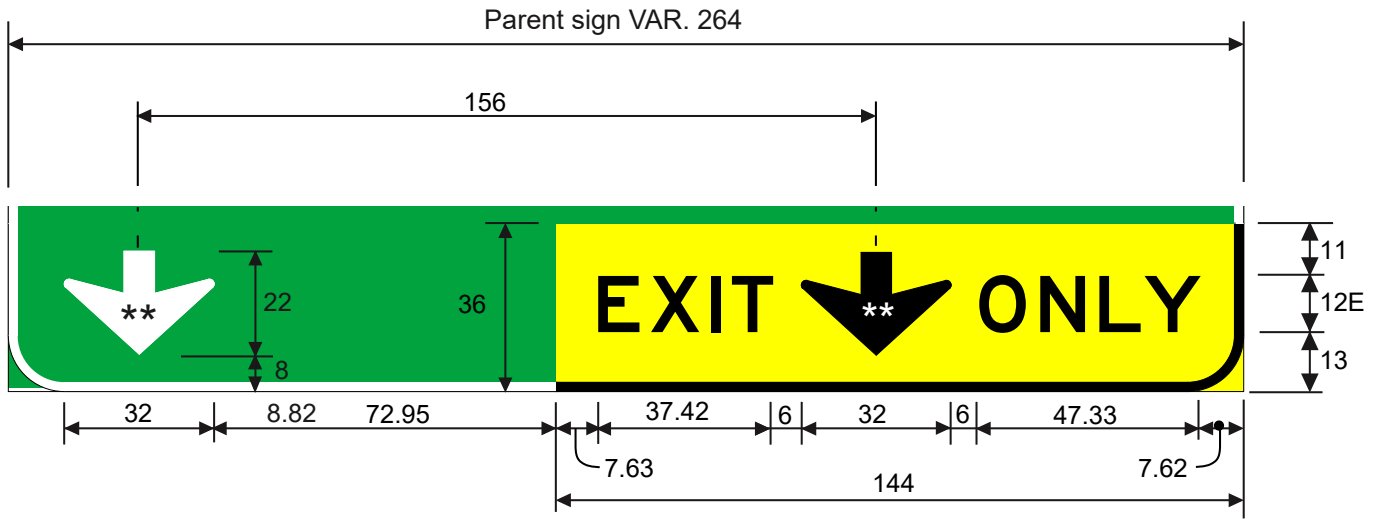

E11-1dT
EXIT ONLY (Down Arrow)

** See Symbol section for DOWN arrow design

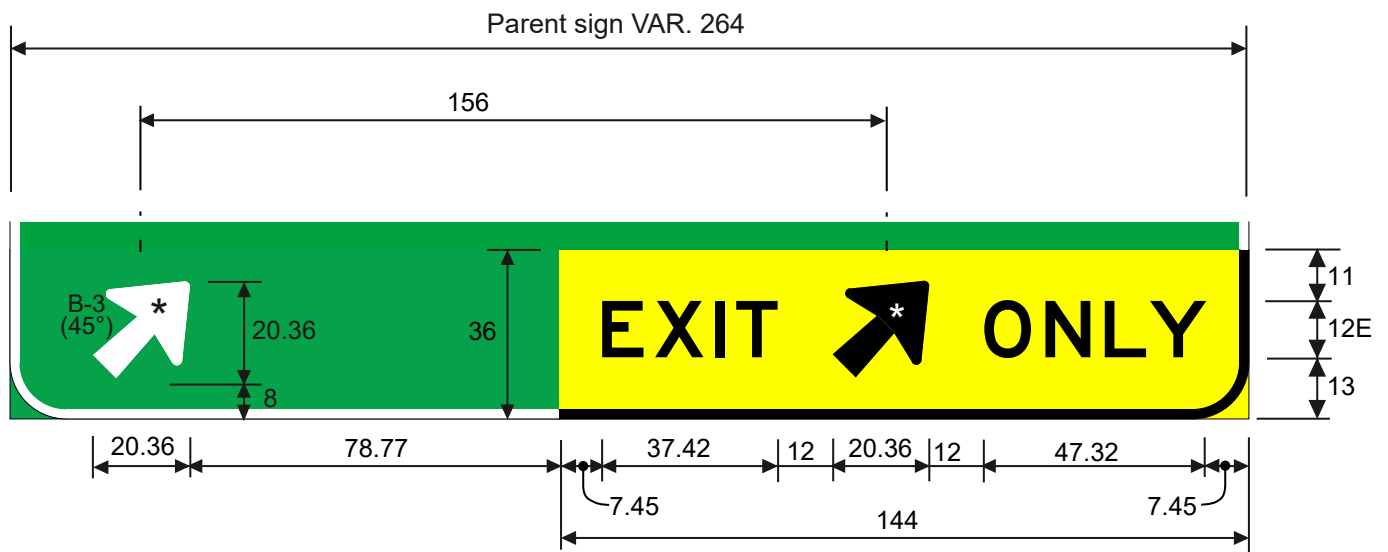

E11-1eT
EXIT ONLY (45 Degree Arrow)

* See Symbol section for B3 arrow design

COLORS: LEGEND - BLACK
BACKGROUND - YELLOW

TEXAS

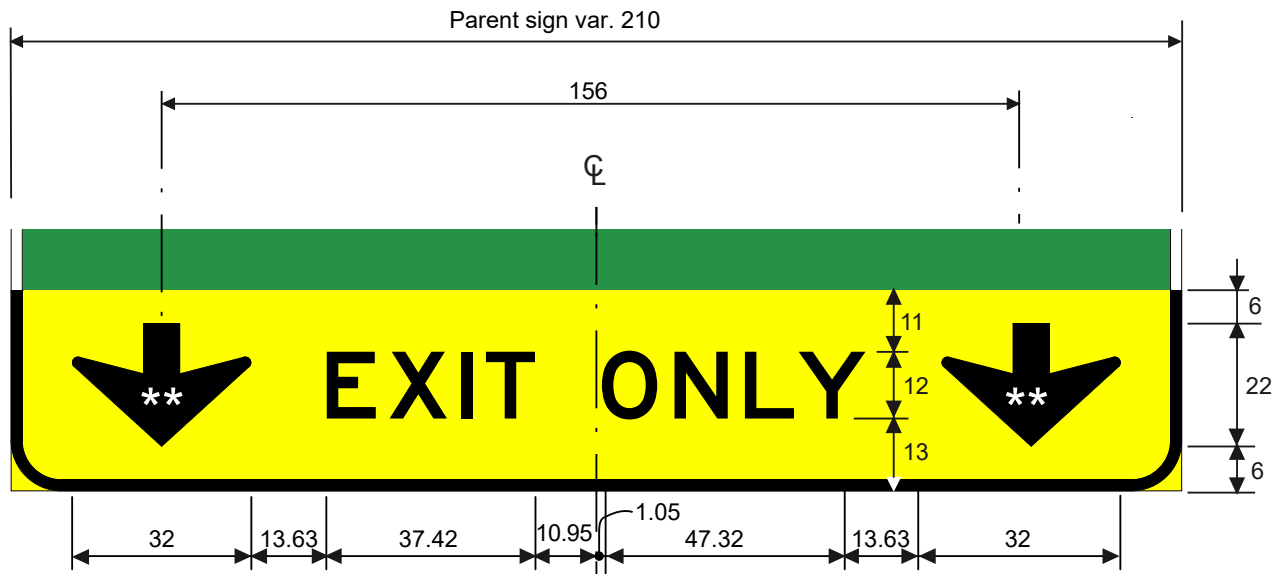

E11-1fT
EXIT ONLY (2 - Down Arrow)

** See Symbol section
for DOWN arrow design

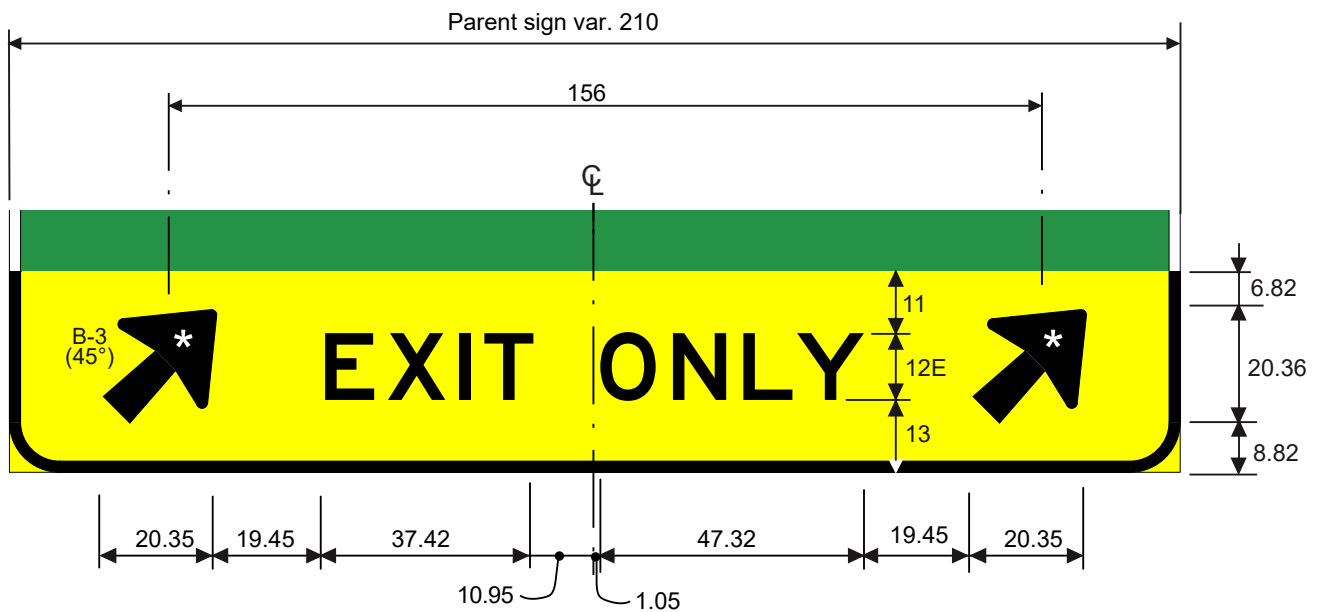

E11-1gT
EXIT ONLY (45 Degree Arrow)

* See Symbol section
for B3 arrow design

COLORS: LEGEND - BLACK
BACKGROUND - YELLOW

TEXAS

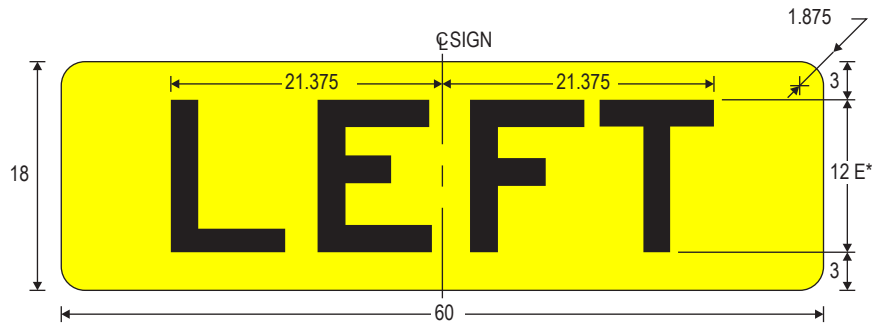

E11-2
LEFT * Increase character spacing 25%.

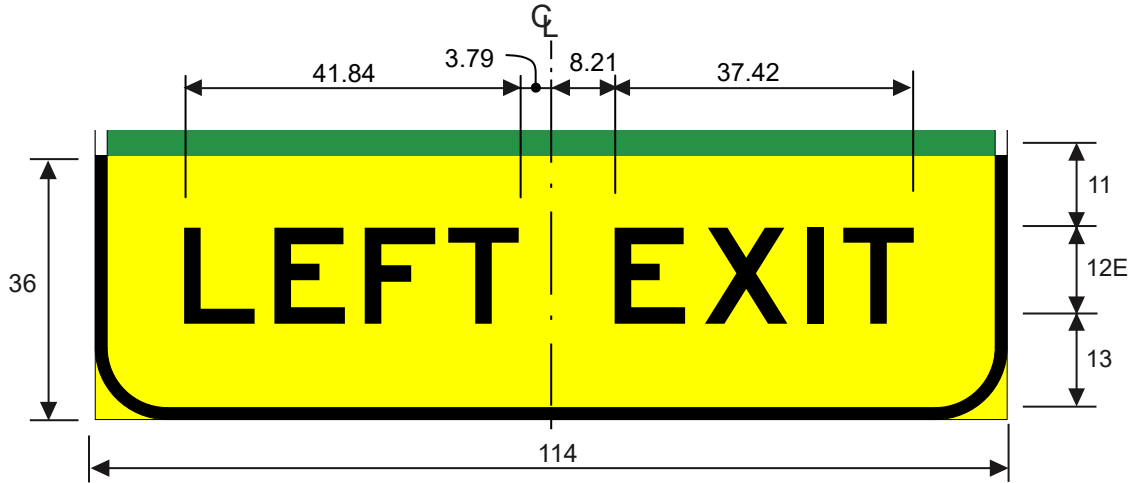

E11-2aT
LEFT

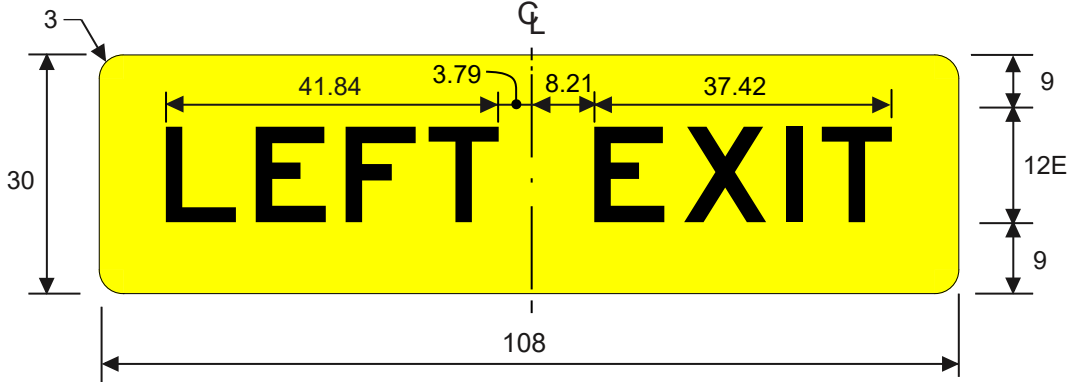

E11-2cT
LEFT EXIT

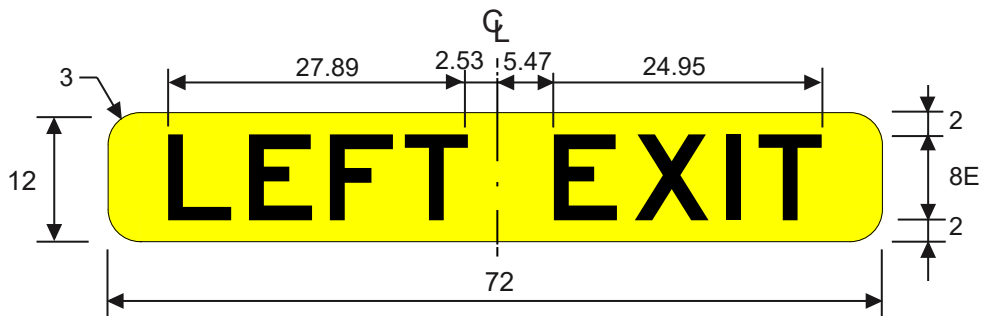

E11-2dT
LEFT EXIT

COLORS: LEGEND - BLACK
BACKGROUND - YELLOW

TEXAS

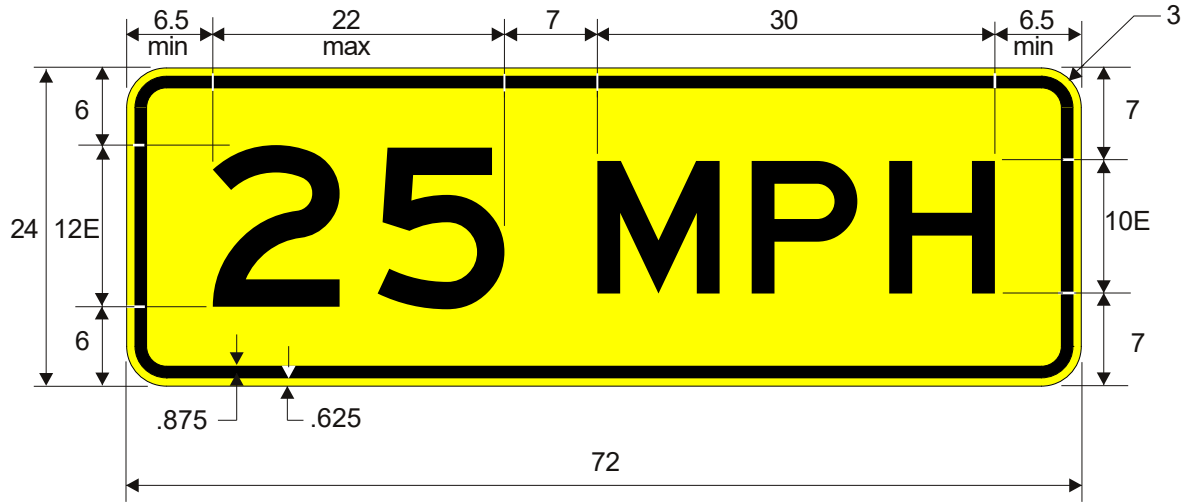

E13-1P

Exit Gore Advisory Speed (Plaque)

COLORS: LEGEND - BLACK
BACKGROUND - YELLOW

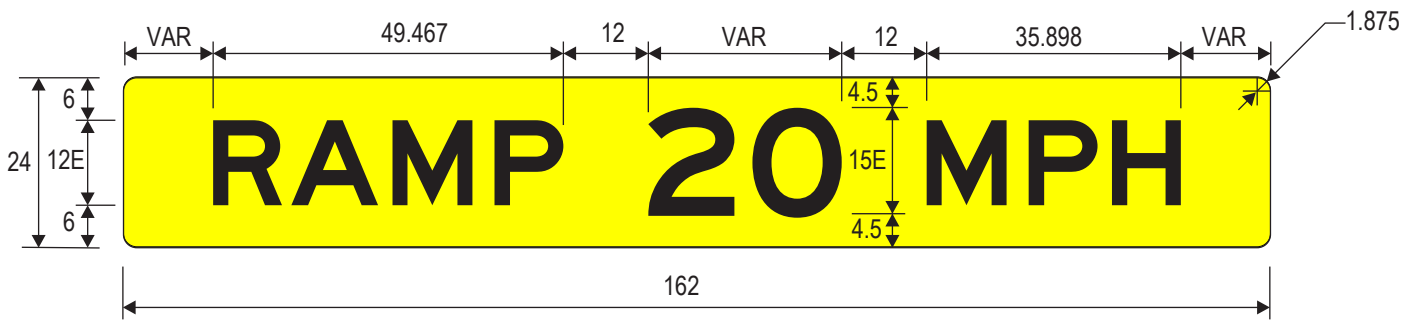

E13-2

Ramp/Exit Advisory Speed

- OR -

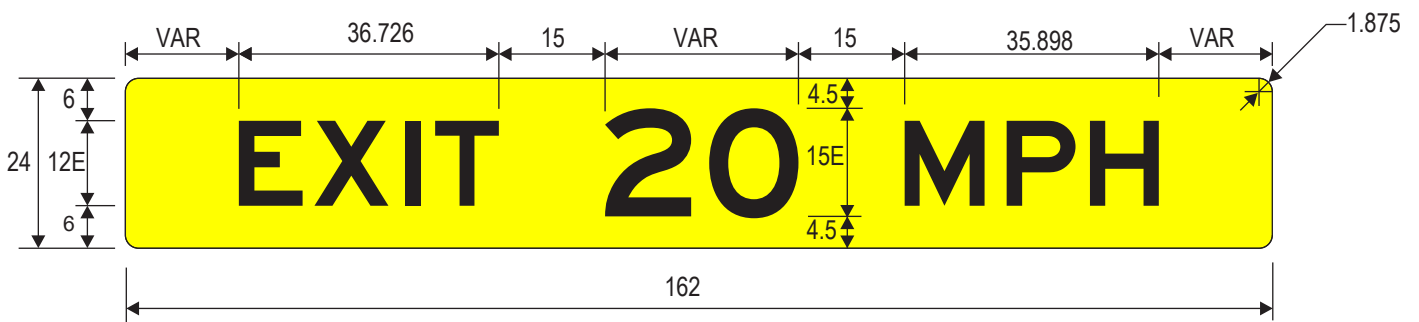

E13-2

Ramp/Exit Advisory Speed

COLORS: LEGEND - BLACK
BACKGROUND - YELLOW
NO BORDER



E21-1T
REST AREA X MILES



E21-2T
REST AREA NEXT RIGHT

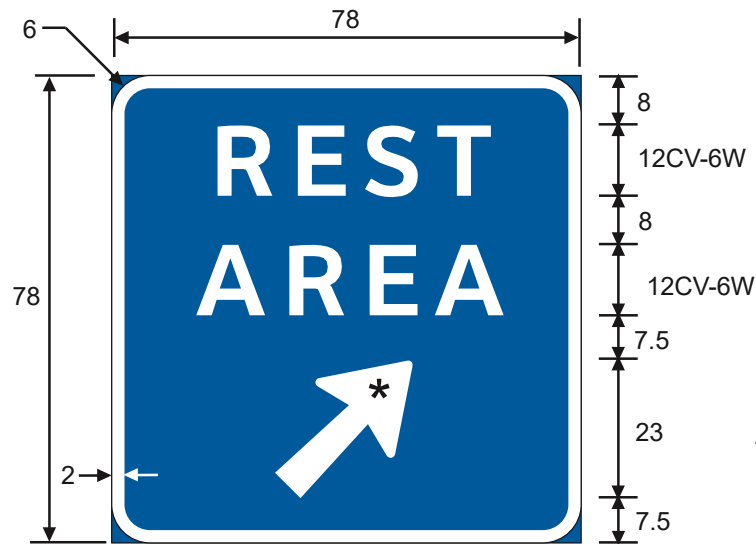

* See Symbol section for arrow design

E21-3T
REST AREA (45 Degree Arrow)
COLORS: LEGEND - WHITE
BACKGROUND - BLUE

TEXAS



E21-4T
 PICNIC AREA X MILES
 120



E21-5T
 PICNIC AREA NEXT RIGHT

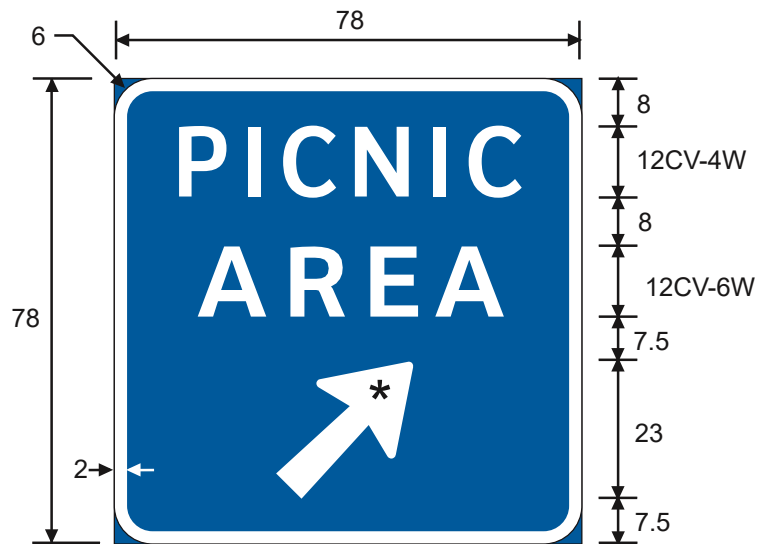

* See Symbol section
 for arrow design

E21-6T
 PICNIC AREA (45 Degree Arrow)
 COLORS: LEGEND - WHITE
 BACKGROUND - BLUE

TEXAS



E21-7T
NEXT REST AREA XX MILES

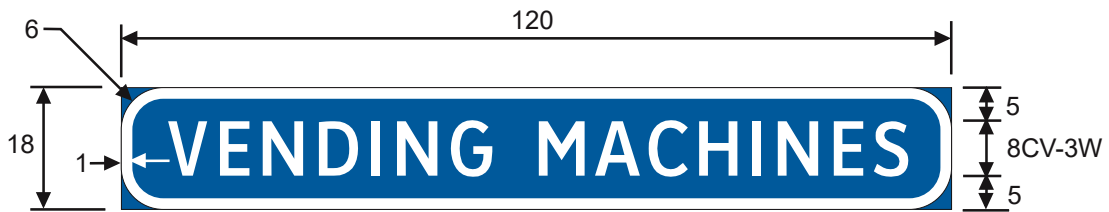

E21-8T
VENDING MACHINES

COLORS: LEGEND - WHITE
BACKGROUND - BLUE

TEXAS



E21-9T
REST AREA TOURIST INFO CENTER X MILE



E21-10T
NEXT RIGHT

COLORS: LEGEND - WHITE
BACKGROUND - BLUE

TEXAS



E21-11T

REST AREA TOURIST INFO CENTER (45 Degree Arrow)

* See Symbol section
for arrow design

COLORS: LEGEND - WHITE
BACKGROUND - BLUE

TEXAS

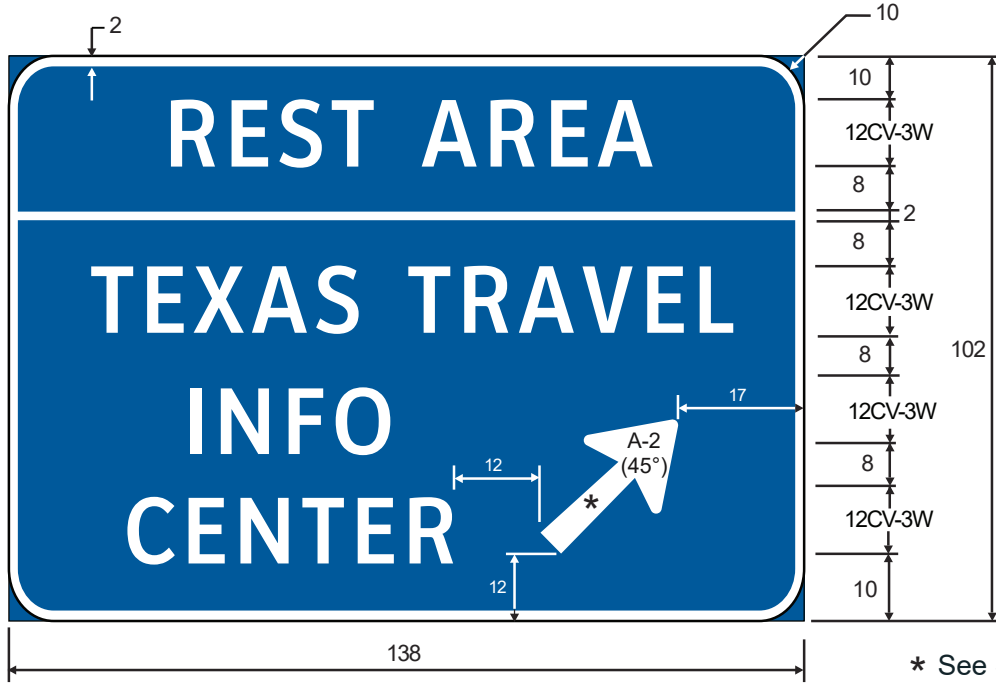

E21-12T

REST AREA TEXAS TRAVEL INFO CENTER (45 Degree)

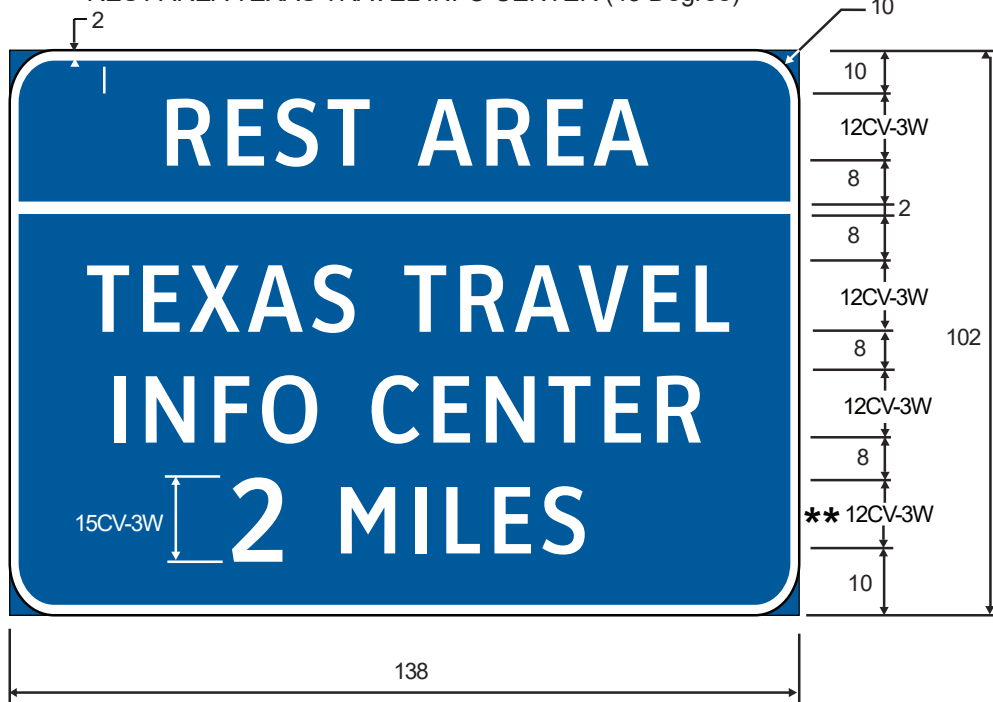

E21-13T

REST AREA TEXAS TRAVEL INFO CENTER X MILES



E21-14T

REST AREA TEXAS TRAVEL INFO CENTER NEXT RIGHT

COLORS: LEGEND - WHITE
BACKGROUND - BLUE

TEXAS



E22-1T

VETERANS AFFAIRS HOSPITAL NEXT RIGHT

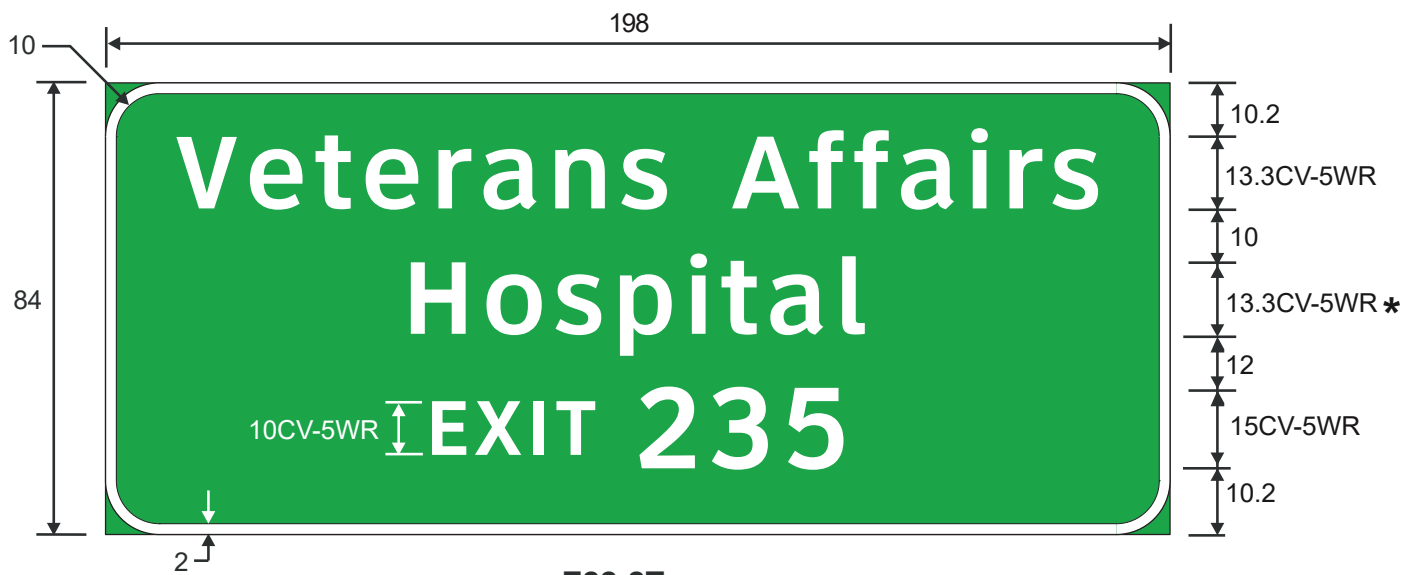

E22-2T

VETERANS AFFAIRS EXIT XXX

* Alternate text:

Cemetery
Medical Clinic

COLORS: LEGEND - WHITE
BACKGROUND - GREEN

TEXAS



D7-1T (F) for Freeway
STATE / NATIONAL PARK EXIT XXX



D7-1T (F) for Freeway
STATE / NATIONAL PARK NEXT RIGHT

COLORS: LEGEND - WHITE
BACKGROUND - BROWN

TEXAS